

5-18-2021

A New Flexible Electronic Overload Protective Relay.

Ibrahim El-Sayed

Faculty of Engineering and Technology, Helwan, Cairo, Egypt.

Follow this and additional works at: <https://mej.researchcommons.org/home>

Recommended Citation

El-Sayed, Ibrahim (2021) "A New Flexible Electronic Overload Protective Relay.," *Mansoura Engineering Journal*: Vol. 15 : Iss. 1 , Article 7.

Available at: <https://doi.org/10.21608/bfemu.2021.170551>

This Original Study is brought to you for free and open access by Mansoura Engineering Journal. It has been accepted for inclusion in Mansoura Engineering Journal by an authorized editor of Mansoura Engineering Journal. For more information, please contact mej@mans.edu.eg.

A New Flexible Electronic Overload Protective Relay

محم إلكتروني جديد من لفرقا به قد زيادة الاحمال

Ibrahim Fatouh El-Sayed

FACULTY OF ENGINEERING AND TECHNOLOGY, HELWAN, CAIRO, EGYPT

الغلامه، يقدم هذا البحث وصف لمتمم إلكتروني جديد لفرقا به الاحمال المتناميه قد زيادة الاحمال وعدم الاتزان ويحمل النظام تبعاً لتعامل نبضات متوالية حيث يعتمد وزن النبضات على زيادة تيار العمل. ويوضح البحث ان النظام يتميز في انه يمكن تغيير غرض الحماية المطلوبه. ولقد دومي في تصميم هذا النظام ان يؤدي إلى حمايه مكثي حتى يمكننا من الاستفادة الطمسي من الاله وتحليل الزمن الغير فعال. هذا يقدم البحث شرح مفصل لتدافره الإلكترونيه وإحتياجات للمعادلات التي تصف أداء المتمم في حالات مختلفه. وفي النهايه يوجد تحميم مكملي للمتمم الإلكتروني المتخذ مملها ومخارطة للتخالف العمليه مع النتائج التقريه.

Abstract: This paper describes and implements an electronic relay scheme which protect industrial loads against overload and unbalance. The scheme works on a principle of integrating a pulse train. The strength of these pulses depends on the excess of current over the nominal value. It is shown that the presented scheme is capable of having variable overload protection characteristics. The relay design is directed to attain optimum overload protection that provides maximum use of motor and minimum waste operation time. The electronic circuit is described in details and different operating modes are studied. Experimental and analytical results are given and discussed.

1 Introduction

Proper protection system prevents nuisance tripping while at the same time permitting maximum motor utilization without degrading insulation and causing premature motor failures.

Overload protection of industrial loads that use thermo-mechanical relays suffers from many shortcomings that are discussed in details in [2],[3].

Electronic replacement of the thermo-mechanical devices ensures low failure per operation rates and also provides greater versatility to the protection systems.

Today high relaying performance on a semi-conductor chip of LSI circuits can be obtained [1].

Basically the problem to be solved is the motor heating, not overload or unbalanced terminal conditions. In cases of repetitive starting and repetitive transient overload, the motor windings may get considerable heat and yet the protection relay may not operate. The repetitive starting case may be considered by the operator. But the repetitive transient overload case is undetectable by the operator and may cause serious damage.

To overcome this problem, the work [3] chooses a constant lag time between the termination of a fault (or overload) condition and resetting the integrator. His feasible choice is half the time taken by the load to cool down to its normal operating temperature after suffering the severest transient fault condition. This may cause bad utilization of the operation. Moreover, the use of flip flop integrated circuits and nonlinear elements adds complexity to the relay operation and noise problems.

This paper describes an electronic relay scheme which protects industrial loads against overload and unbalance. The time-overload characteristics can be set according to the load ratings and can be made faster or slower to suit different load dynamic requirements. The circuit is designed so that the characteristics should conform to those of present thermo-mechanical devices that need replacement. Moreover, the relay works according to the history of operation in order to avoid instantaneous resetting or waiting more time than is actually needed.

2 Protection Basic Operation

The configuration of overload protection is shown in Fig. 1. Normally, the electronic device drives a low power semi-conductor switch that provides a path for the circuit breaker energizing coil current, thus keeping the supply on.

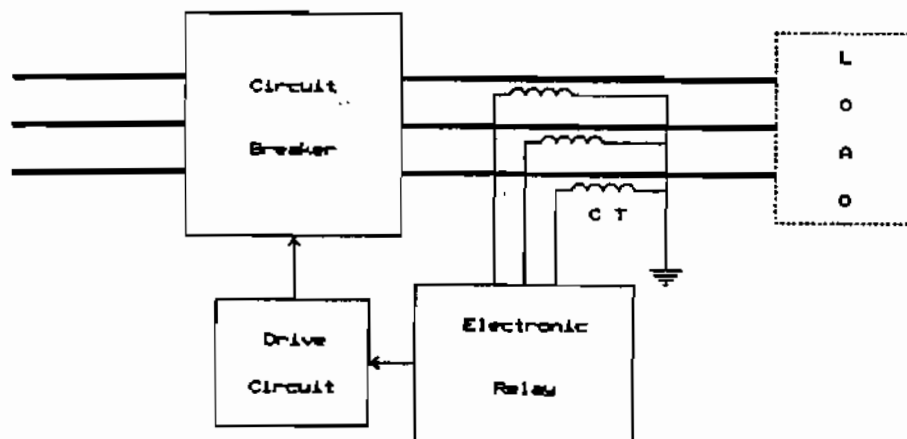

Fig. 1. Basic configuration of electronic relay

The electronic circuit detects the overcurrent and/or unbalance through current transformers. If the fault condition persists, the electronic circuit stops driving the static switch that blocks the circuit breaker energizing coil current after a certain time which is dependent on the magnitude of the overcurrent. This results in a shut-off of the system.

Today, the developments in the field of power semiconductor circuit breakers are attractive. However, there has been growing interest in GTO, thyristor and power transistor circuit breakers for short circuit fault protection, and industrial applications [8].

In case of using power semi-conductor circuit breaker, the low power semi-conductor switch can be omitted and the drive circuit can control the power device in one step

3 Operation Principle of the Electronic Relay

An industrial overload protection device with controllable inverse time-current characteristics can be achieved by integrating a train of pulses. The strength of these pulses is controlled by the overload current. Both width and amplitude of these pulses are controlled by the excess of the current over the nominal value.

Current signal

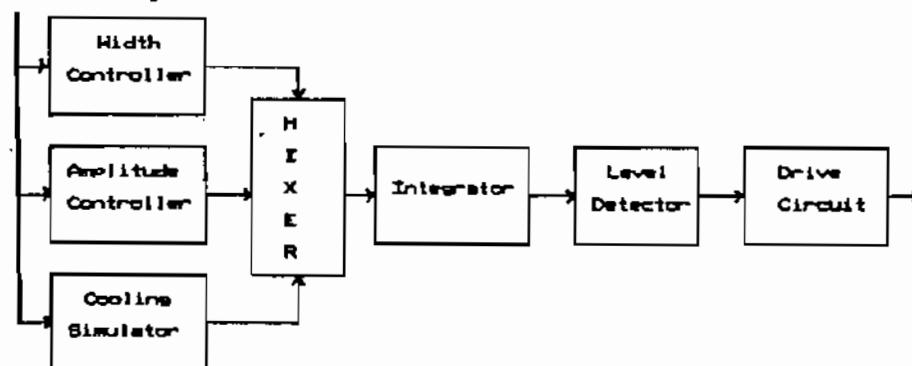

Fig. 2. Functional block diagram of the electronic relay

Simply the sum of the measured 3-phase current signals are used to protect the load against unbalanced residual operating conditions; protection against other unbalances are also feasible. The block diagram in Fig. 2 illustrates the idea of the proposed electronic relay.

The width controller compares the measured sine wave current signal with a DC level. It produces a square wave with width dependent on the overcurrent.

The amplitude controller produces a DC signal that is proportional to the overcurrent value.

The output signals of width and amplitude controllers are now processed in the mixer to obtain a train of pulses. The width and amplitude of these pulses are dependent on the overcurrent value.

The integrator output is proportional to the strength of all foregoing pulses obtained by the mixer.

The crossover of a predetermined level by integrator output is detected by level detector, causing stoppage of the drive stage.

The cooling simulator produces a signal for discharging the integrator according to the under loading level. It simulates the cooling process of the protected machine.

For conducting static switch case, the drive circuit produces firing pulses for thyristors (or GTO) and base drive current in case of power transistors. If the overcurrent has elapsed its time, the drive circuit stop signalling the static switch.

3.1 Pulse Strength Control

The basic function of the controllers are to control the amplitude and width of the mixer output pulses depending on the time-overcurrent characteristics required. Thus the controller design cannot be a unique one. Here different control methods are suggested.

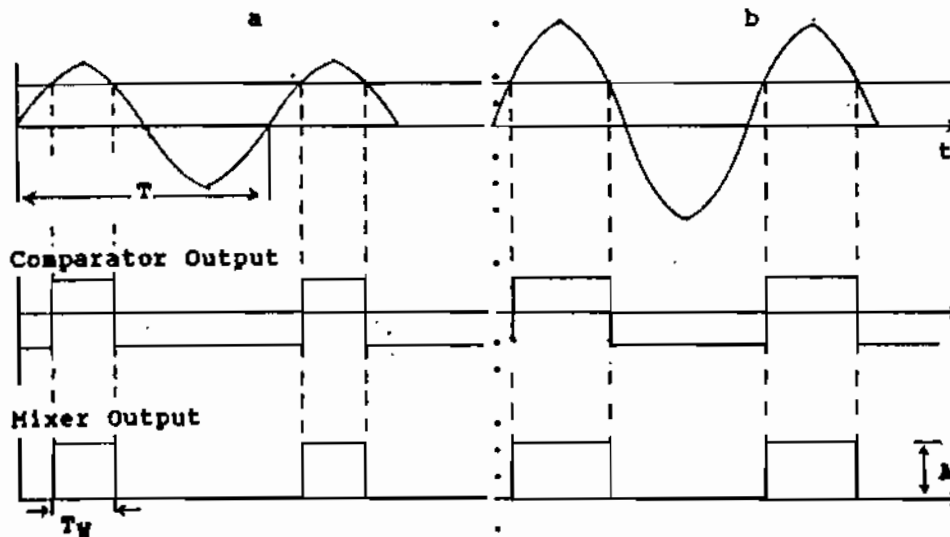

Fig. 3. Waveforms for operation at different overload currents (mode-1)

3.1.1 Dependent width - constant amplitude mode (Mode-1)

Fig. 3 illustrates the generation of rectangular pulses by comparing the line current signal $X \cdot I_N \sin(\omega t)$ with a DC level corresponding to the nominal current I_N . The variation of load current affects the width of the rectangular pulses only. The time width T_w can be expressed as a function of overloading factor X by eq. (1).

$$T_w = \frac{[\pi - 2 \sin^{-1}(1/X)]}{\omega} \quad (1)$$

Where $X = I/I_N$

Defining the strength of a pulse to be the product of its amplitude and width, each pulse strength will be given by

$$S(X) = \frac{A [\pi - 2 \sin^{-1}(1/X)]}{\omega} \quad (2)$$

Since the integrator accumulates the history of these pulses, the sum of $S(X)$ will be accumulated at its output. The tripping will occur if the integrator output exceeds the predetermined trip level value V_{trip} .

The trip condition under steady state is given by,

$$V_{trip} = N \cdot S(X) \quad (3)$$

Substituting number of pulses N with its equivalent T_{trip}/T in eq. (3), the trip time-pulse strength relationship would be given by,

$$T_{trip} = \frac{V_{trip} \cdot T}{S(X)} \quad (4)$$

Using eq. (2) and (4), the trip time will be

$$T_{trip} = \frac{V_{trip} \cdot T \cdot \omega}{A \cdot [\pi - 2 \sin^{-1}(1/X)]} \quad (5)$$

Standardizing the constants in eq. (5) so as to get a general tripping time of T_{trip0} for overcurrent fault X_0 , eq. (5) will be modified to be

$$T_{trip} = \frac{T_{trip0} [\pi - 2 \sin^{-1}(1/X_0)]}{[\pi - 2 \sin^{-1}(1/X)]} \quad (6)$$

$$\text{Where } T_{trip0} = \frac{V_{trip} \cdot T \cdot \omega}{A [\pi - 2 \sin^{-1}(1/X_0)]}$$

3.1.2 Dependent width - dependent amplitude mode (Mode-2)

In fig. 4, the variation of load current affects both width and amplitude of the rectangular pulses.

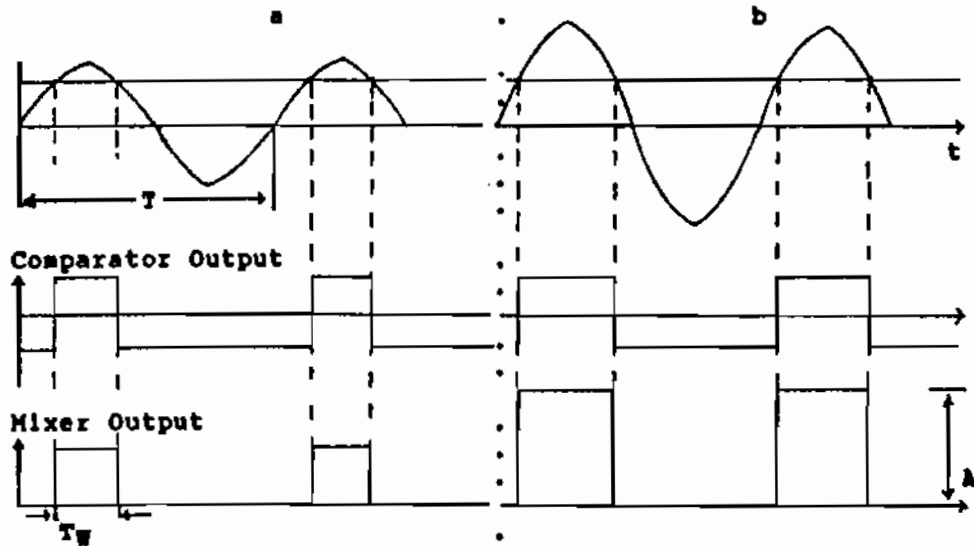

Fig. 4. Waveforms for operation at different overload currents (mode-2)

The pulse strength $S(X)$ in this case will be given by,

$$S(X) = \frac{k \cdot I_M \cdot (X-1) \cdot [\pi - 2 \sin^{-1}(1/X)]}{v} \quad (7)$$

Proceeding along the same steps of mode-1, the trip time-overload relationship for mode-2 will be

$$T_{trip} = \frac{T_{trip0} \cdot (X_0-1) \cdot [\pi - 2 \sin^{-1}(1/X)]}{(X-1) \cdot [\pi - 2 \sin^{-1}(1/X)]} \quad (8)$$

4 Relay Characteristics

The obtained eq. (6) and (8) are the trip time-overload relationship in mode-1 and -2 respectively.

In order to evaluate the relay characteristics, a predetermined operating point should be substituted in eq. (6) and (8). For example, if the relay should trip after $T_{trip0} = 1$ sec for overload of $X_0 = 10$, the trip-overload characteristics obtained by eq. (6) for mode-1 and eq. (8) for mode 2 are given in Fig. 5.

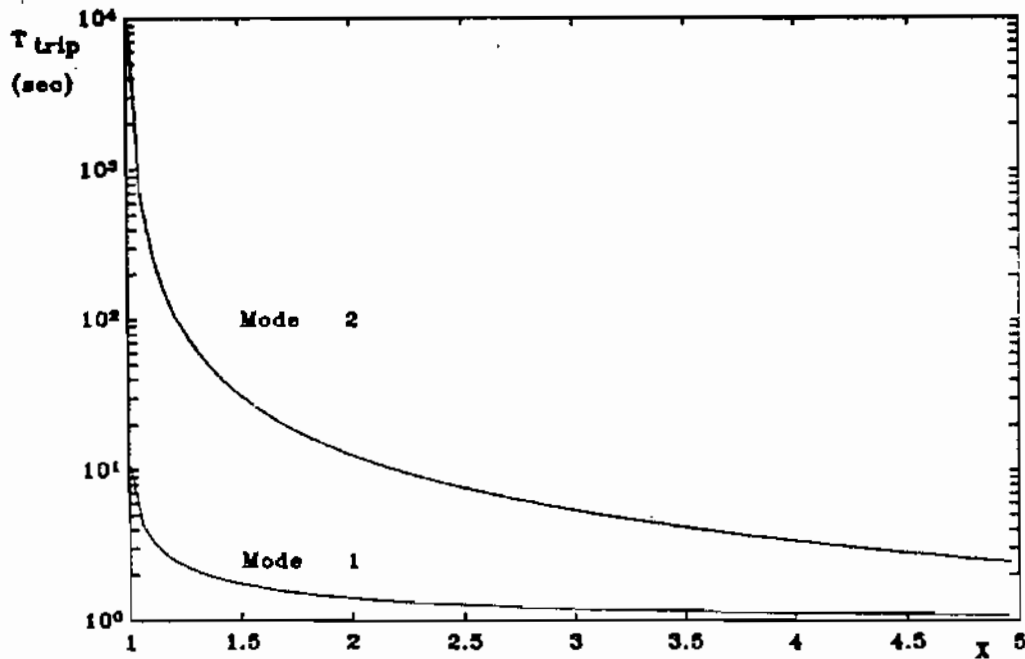

Fig. 5. Trip time-overload characteristic of the electronic relay

Mode-1

Since the pulse width depends on the intersection between a constant level with sine-function, it is easy to conclude that:

the pulse width increases rapidly at beginning of overloading, but at high overloading values the width-overload tends to be linear. This explains the very fast change in trip time when overloading less than 120%. For overloading more than 300%, the change in trip time is not considerable.

Mode-2

The equation that describe mode-2 is a product of mode-1 with an inverse function. This is due to the double effect of overloading on the pulse strength $S(X)$. These effects provide another characteristic as shown in Fig. 5.

5 Electronic Relay Implementation

A hardware implementation of a static relay for mode-2 is shown in Fig. 6. The wave shapes shown in Fig. 4 describes the operation of the proposed circuit.

The excess of load current produces a pulse train at the output of comparator IC1. The width of this pulse depends on

the overload current. Waveforms a and b illustrate the variation in width of the comparator output depending on the amount of overload.

The transistor switch T is used to change the pulse level from $-V_c, +V_c$ into $0, +V_c$ level.

A DC level proportional to the load current is obtained at the output of amplifier IC5.

During the on time of transistor T, the mixer output depends on the overload excess negative value and the positive value V_c conducted by the transistor. The amplification of IC2 stage are adjusted so that a negative output is obtained at maximum expected overload.

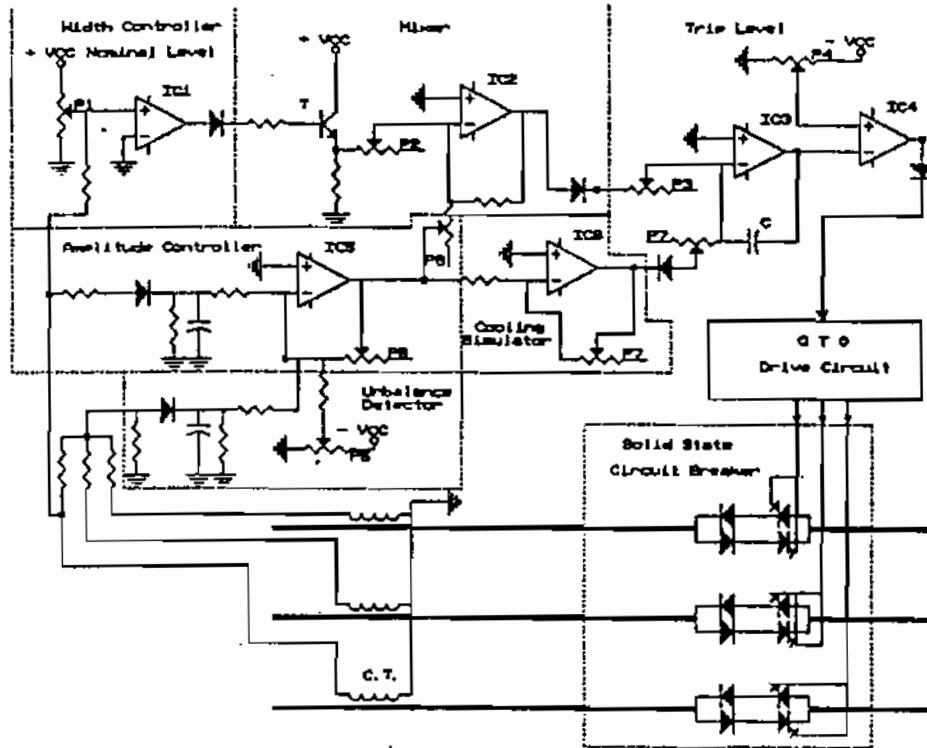

Fig. 6. Hardware implementation of the electronic relay

During the off-time, the mixer output will be positive and depends on the overload level delivered by IC5.

The switching on and off of V_c by the transistor T will be mixed with the overload level to get width and amplitude dependent pulse train.

These pulses are integrated by integrator IC6 and the output is compared with the predetermined level V_{trip} .

A stop signal is produced when the integrator output exceeds the trip level. The integration constants p_3 and C control the integration rate.

The speed of the system response can be controlled by adjusting the potentiometer p_3 .

The cooling simulator discharges the integrator in case of underload. The speed of discharging should represent the cooling rate of the protected motor.

By adjusting the relay constants, a family of characteristics can be obtained.

5.1 Static circuit breaker

During the few last years, many industrial researches have developed investigations on static switching devices for many applications. The high rating and variety of new power electronic components (Thyristors, Power Transistors, Gate-Turn Off Thyristors, ...) give flexibility for using static circuit breakers [8].

The static devices offer outstanding switching characteristics. The power MOSFET transistors allow switching times in order of a microsecond, (lower than response times of the electromechanical circuit breakers).

In addition to the decrease of mass, the static circuit breakers offer many advantages in comparison with the classical devices such as:

- * its full autonomy, adjustability and reliability.
- * very fast.
- * the cost is competitive.
- * it assumes more functions than an electro-mechanical circuit breaker.
- * no electric arc which exhibits no maintenance, a good stability of the switching characteristic and the ability to use in inflammable environment.
- * no rebounding, and so no voltage transients.
- * very low control energy.
- * noiseless working.
- * feasibility of setting a telecontrol, by optical fiber for instance.

The static circuit breaker shown is composed of GTO, diode, varistor (not shown). The GTO is used to get very fast interruption than thyristors. Hence a nonlinear resistance such as varistor should be connected in parallel to the switch in order to absorb the spikes generated due to fast interruption. The series diode is added to increase the reverse blocking capability of the switches that use GTO thyristors.

6 Experimental Results

The described electronic circuit is designed and constructed with standard IC 741 and Darlington transistor TIP 121. The design is based on linear elements to get easy adjustment and high reliability. Moreover, the linear elements are not sensitive to the noise compared with flip flop elements.

The trip time is measured by using a storage oscilloscope unit, where the current and trip signals are recorded at the same time.

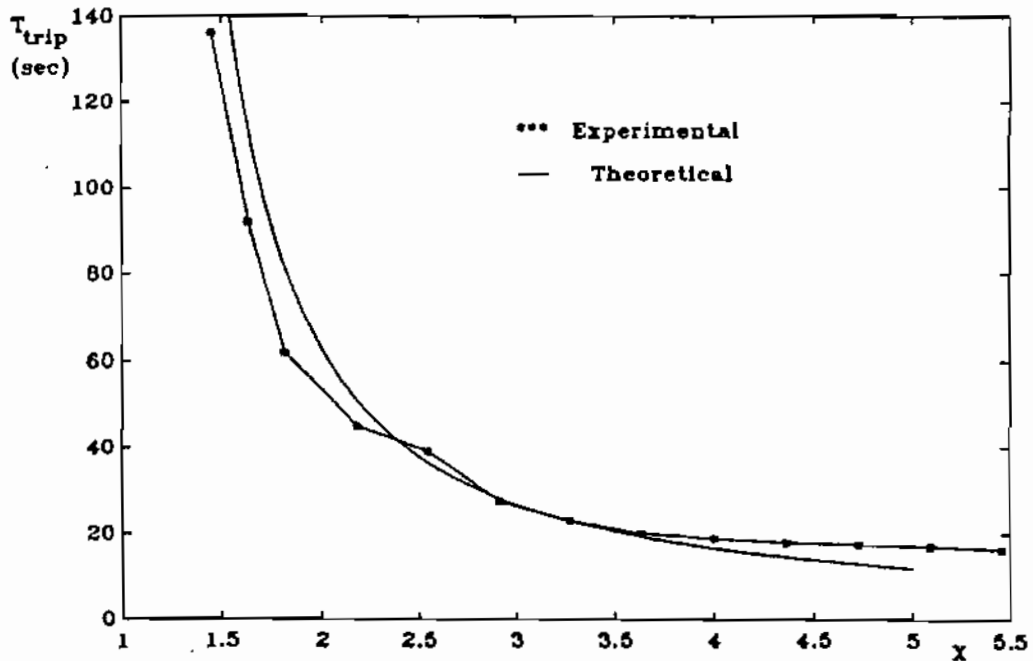

Fig. 7. Experimental and analytical performance

A comparison between experimental and theoretical results is given in Fig. 7. The deviations between the two curves are due to

- *Measurement errors
- *Loading effects on the smoothing capacitor used in amplitude controller stage shown in Fig. 6.

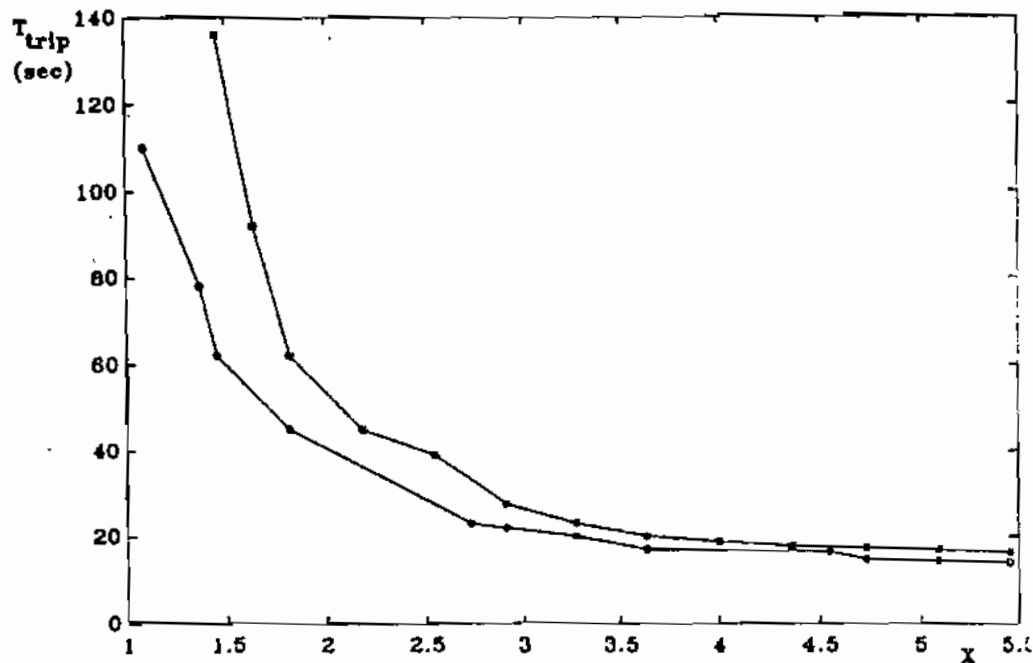

Fig. 8. Experimental relay characteristic for different trip level

The characteristics obtained in Fig. 8 correspond to a slower and faster response of the relay when the trip level is reduced to 50% by using potentiometer p4. It is clear that variations in speed response against overload can be obtained through a simple potentiometric control.

6 Conclusion

The time-overload characteristics of the implemented relay can be set according to the load ratings and can be made faster or slower to suit different load dynamic requirements.

The variation in speed of response against overload can be obtained through a simple potentiometer. The relay works according to the history of operation. Hence, this relay can be a true model of the reaction to overload and underload conditions. This avoids instantaneous resetting or waiting more time than required.

Because the failure rate of semiconductor elements does not depend on the number of actual operations through which they are used, the reliability of this relay will be better than the thermo-mechanical relays.

Since the burden ratings of the used current transformer is very low, they may be made small in size and comparatively cheap.

The investigation should be devoted to consider ambient temperature to get optimum protection by using the described electronic relay in this work.

References

- [1] Chiba, T.; Kudo, H.; Watanebe, A.; Goto, M.; Kido, M.; Seo, K.: Development of Custom LSIS for Protection Relays and Their Evolution to New Static Relays. IEEE Trans on Power Delivery, Vol. 3, Jan. (1988) no. 1, p.130-137
- [2] Paape, K. L.; Sr; Mantha, M. J.: Trade-Offs in Overload Protection for Low Voltage Motors. IEEE Trans. on Industrial Applications, Vol. IA-18, March/April (1982) no. 2, p.110-119
- [3] Das, S.K.: An Electronic Replacement for thermo-mechanical Load Protection Devices. IEEE Trans. on Industrial Electronics, Vol. IE-29, February (1982) no. 1, pp. 52-55
- [4] Klob, A.F; Thom, H.W.: Motor Protection Characteristics of ambient Insensitive Overload Devices. IEEE Trans. on Industry Applications, Vol. IA-15, May/June (1979) no. 3, p.303-312
- [5] Lie, Z.; Zhi-Jing, Z.: Studies of Distance Protection with a Microprocessor for Short Transmission Lines. IEEE Trans. on Power System. Vol. 3, February (1988) no. 1, p.330-336
- [6] Griffin, C. H.; Pope, J. W.: Generator Ground Fault Protection Using Overcurrent, Overvoltage, and Undervoltage Relays. IEEE Trans. on Power Apparatus and System, Vol. PAS-101, December (1982), no. 12, p.4490-4501
- [7] Al-Nema, M.A.; Bashi, S.M.; Ubaid, A.A.: Microprocessor-Based Overcurrent Relays. IEEE Trans. on Industrial Electronics, Vol. IE-33, February (1986), no. 1, p.49-51
- [8] Jinzenji, T.; Tkudor, T.: A GTO DC Circuit Breaker Controlled by a Single-Chip Microcomputer. IEEE Trans. on Industrial Electronics, Vol. IE-32, February (1986) no. 3, p.204-209
- [9] Delerol, W.: Three Phase AC Chopper for Switching Induction Motor Without Transients. Second European Conference, (1987) p.1009-1014
- [10] Salove, S.: Methods and Techniques of Protecting Relays from Transient Surges. IEEE Trans. on Industrial Applications, Vol. IA-16, January/February (1980) no. 1, p.60-64