

8-8-2021

## The Application of Linear Elastic Fracture Mechanics Analysis to Bluntly Notched Round Bar Specimens.

Mohamed Shabara

*Associate Professor., Production and Mechanical Design Engineering Department., Faculty of Engineering., El-Mansoura University., Mansoura., Egypt.*

Follow this and additional works at: <https://mej.researchcommons.org/home>

---

### Recommended Citation

Shabara, Mohamed (2021) "The Application of Linear Elastic Fracture Mechanics Analysis to Bluntly Notched Round Bar Specimens.," *Mansoura Engineering Journal*: Vol. 16 : Iss. 2 , Article 19.  
Available at: <https://doi.org/10.21608/bfemu.2021.188144>

This Original Study is brought to you for free and open access by Mansoura Engineering Journal. It has been accepted for inclusion in Mansoura Engineering Journal by an authorized editor of Mansoura Engineering Journal. For more information, please contact [mej@mans.edu.eg](mailto:mej@mans.edu.eg).

THE APPLICATION OF LINEAR ELASTIC FRACTURE MECHANICS  
ANALYSIS TO BLUNTLY NOTCHED ROUND  
BAR SPECIMENS

تطبيق تحليلات ميكانيكا الكسر على العينات الاسطوانية ذات  
الخدوش الغيـر حـاد

BY

M.A.N. SHABARA

Faculty of Engineering, Mansoura  
University, Mansoura

**خلاصة :** في هذا البحث تم تقديم طريقة تسمح باستخدام عينات صغيرة اسطوانية ذات الخدش الدائري بدون احداث شرخ كلال بها ، لاجاد متانة الكسر للمواد الهندسية . والطريقة مبنية على تحليلات ميكانيكا الكسر ومبدأ معامل تركيز الاجهادات عند مقدمة الخدش . أما الخطأ الحادث في حساب متانة الكسر في هذه الطريقة ( أي في حالة الخدش غير الحاد ) فأمكن تصحيحه باستخدام معامل تصحيح دالة في نصف قطر تقوس مقدمة الخدش (  $r/d$  ) وقد طبقت هذه الطريقة والمعادلة المستنتجة منها تجارب حساب متانة الكسر لسببكتين معدنيتين هما الصلب عالي المقاومة والبرونز الفوسفوري حيث اختبرت بالشد عينات ذات خدوش دائرية على شكل حرف Y ذات زوايا وأنصاف أقطار مختلفة ، وعقدت مقارنة بين القيم الناتجة لمتانة الكسر باستخدام المعادلة المقترحة في هذا البحث ومعادلة أخرى ، واتضح وجود توافق معقول بين القيمتين مع وجود فارق صغير بينهما في حدود من صفرا إلى  $\pm 5\%$  ، وحتى يظل هذا الفارق في الحدود المقبولة ينصح بالآ تزيد نسبة نصف قطر الخدش عن  $r/d$  .  
والطريقة المقترحة يمكن اعتبارها طريقة سريعة واقتصادية وتتمتع بمستوى من الدقة يكفي لكثير من الاعراض العملية .

#### ABSTRACT

A technique has been presented which allows the use of small notched round-bar specimens without fatigue pre-cracking for the determination of the plane strain fracture toughness of engineering materials. The technique is based on the linear elastic fracture mechanics analysis and the principle of stress concentration factors at the tip of the notch. The error inherent in the fracture toughness calculations, i.e. due to the absence of very sharp crack, can be corrected from an error correction factor which is a function of the normalized notch-tip radius,  $r/d$ .

The technique has been applied to two metallic alloys (bronze and steel) and the plane strain fracture toughness for the two materials were obtained. Small round-bar specimens having V-notches with different angles and tip-radii have been tested in tension. A comparison of the  $K_{Ic}$  values calculated using the present technique and those calculated in the literature indicated reasonable agreement with a difference between the two values ranging from 0 to  $\pm 5\%$ . It is recommended that the normalized notch-tip ratio,  $r/d$ , should not exceed about 0.14 for this difference to stay within acceptable limits.

The present technique may be considered relatively fast and economic and indicating a level of accuracy adequate for many practical purposes.

#### INTRODUCTION

Testing the fracture toughness of metallic materials generally requires specimens that are relatively large and expensive to machine. These specimens are then fatigue pre-cracked, frequently employing servohydraulic machines. This pre-cracking is, therefore, a slow and expensive exercise. Moreover, large pieces of materials needed for making the specimens may frequently be unavailable. Such specimens are the compact tension specimens with chevron or straight notch as was outlined in ASTM 399[1].

Recently, efforts have been done to overcome these shortcomings by perfecting, simple, quick, and economic technique to estimate the plane strain fracture toughness,  $K_{Ic}$

The notched round bar specimens may be considered the most promising geometry for this purpose [2]. However, fatigue precracking of such a specimen configuration inevitably results in eccentric ligaments which, when loaded in tension, their final fracture will be the result of a combination of tension and bending. The relationship used for computing the critical stress intensity factor is based on tension only, hence its magnitude would be greater if bending is also present. Experimental evidence of ligament eccentricity was observed by Stark et al [2]. A number of investigators have modified the compact fracture specimens by replacing the sharp crack-starter and fatigue precrack with a blunt notch [3,4]. Specimens with such notches are generally used for crack initiation studies from the viewpoint that the blunt notch is representative of machined holes, undercuts, notches, etc. in machine elements. This paper presents analytical and experimental results for linear elasticity which are expected to enhance the usefulness of bluntly notched small round bar specimens. Stress concentration factors are given for a number of variations in geometry. These are compared with estimates based on fracture mechanics, and a method is presented for correcting the inaccuracies of the latter, so that improved estimates may be made. Accordingly, corrected estimates of the plane strain fracture toughness of the materials tested are calculated.

#### THEORETICAL ANALYSIS

At a sharp notch in an elastic body, the maximum stress may be approximated by [5,6] :

$$\sigma = 2 K / \sqrt{\pi r} \quad (1)$$

where  $K$  is the stress intensity factor calculated for the hypothetical case where the notch is collapsed to form a crack of the same major dimensions, and  $r$  is the notch radius. If an arbitrary tensile load,  $P$ , as in Fig. 1, was applied to the body, the resulting maximum principal stress at the notch,  $\sigma$ , is related to the nominal stress,  $S$ , through the equation :

$$k_t = \sigma / S \quad (2)$$

where  $k_t$  is the stress concentration factor.

Equations 1 and 2 give the following estimate of  $k_t$  ( $\bar{k}_t$ ):

$$\bar{k}_t = 2K / S \sqrt{\pi r} \quad (3)$$

where the "bar" sign over  $k_t$  distinguishes this estimate from the actual value of  $k_t$ .

The stress intensity factor,  $K$ , becomes:

$$K = S \bar{k}_t \sqrt{\frac{\pi}{2}} \sqrt{r} \quad (4)$$

For a circular rod with an external circular and coaxial V-notch (Fig. 1) under tension, the exact solution, with an error of the order of  $\pm 1$  percent, is approximated by the Harris formula [7,8]

$$K_I = (\sigma' D^2 / 4d^2)^{1/2} \sqrt{2\pi(D-d)/(D-0.8d)} \quad (5)$$

where  $\sigma'$  is the tensile stress away from the notch tip region; and the subscript 'I' of  $K$  denotes mode I fracture. The nominal stress,  $S$ , is here defined based on tension due to the applied load  $P$  on the net section of the round specimen. This gives :

$$S = 4P / \pi d^2 \quad (6)$$

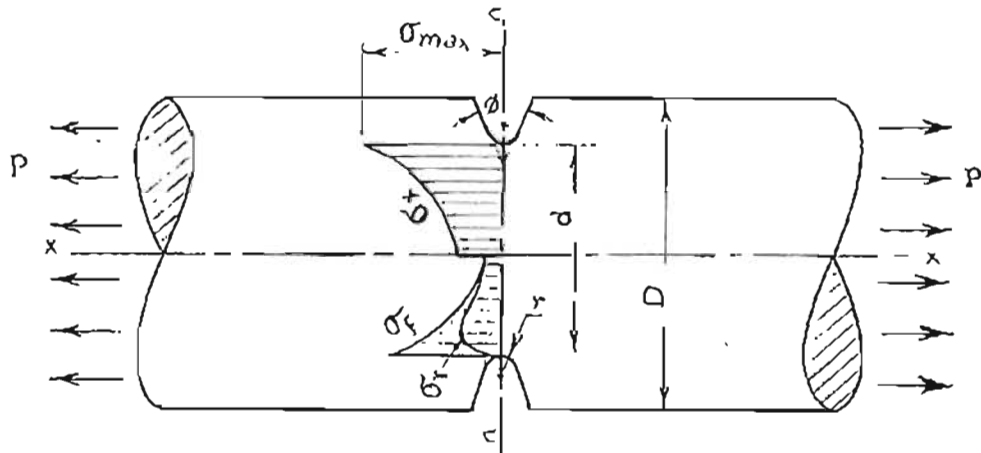

Fig.1 Triaxial Stress State at the Tip of a Circular Coaxial Notch.

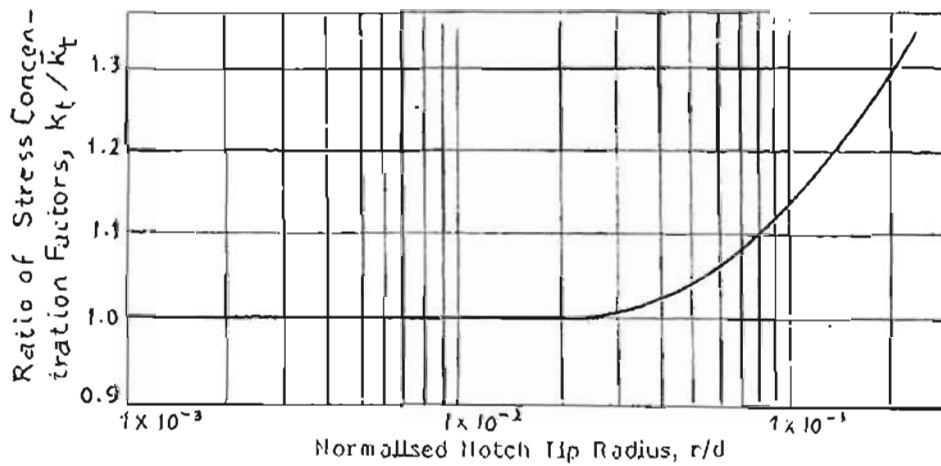

Fig.2 Elastic Stress Concentration Factors,  $k_t$ , for Bluntly Notched Round Bar Specimens with  $D/d= 1.4$  Compared with Estimates based on Fracture Mechanics Analysis.

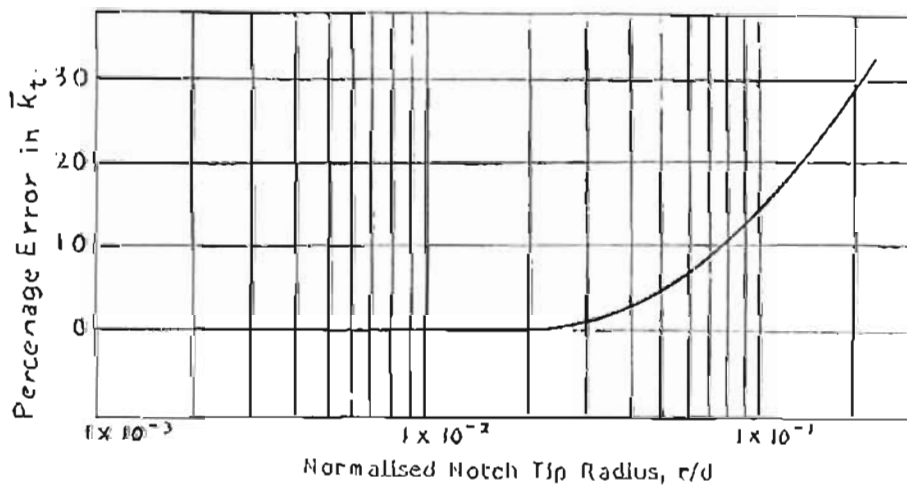

Fig.3 The Percentage Error in Calculating the Stress Concentration Factor as a function of  $r/d$ .

Combining Equations 3, 5 and 6, gives :

$$\begin{aligned} \bar{k}_t &= \frac{2 \sigma D^2}{4 d^{3/2}} \sqrt{\frac{2 \pi (D-d)}{D-0.8d}} / \frac{4 P}{\pi d} \sqrt{\pi r} \\ &= \frac{2}{\sqrt{\pi}} \sqrt{\left(\frac{d}{2}\right) \left(\frac{D-d}{D-0.8d}\right)} = \frac{0.7071}{\sqrt{r/d}} \sqrt{\frac{D/d-1}{(D/d-0.8)}} \end{aligned} \quad (7)$$

Table 1 gives values of  $k_t$  from Eq. 6 for various values of  $r$ .

Table 1. Elastic stress concentration factors from finite element analysis ( $k_t$ ) and estimates based on fracture mechanics ( $\bar{k}_t$ ), Eq. 7, for various bluntly notched round-bar specimens.

$r, mm$	$r/d$	$k_t$	$\bar{k}_t$	$k_t/\bar{k}_t$	$r, mm$	$r/d$	$k_t$	$\bar{k}_t$	$k_t/\bar{k}_t$
0.05	0.008	6.31	6.313	1	0.60	0.100	2.10	1.825	1.151
0.10	0.017	4.48	4.475	1	0.65	0.108	2.04	1.755	1.162
0.15	0.025	3.66	3.654	1	0.70	0.117	1.97	1.690	1.166
0.20	0.034	3.20	3.164	1.011	0.75	0.125	1.93	1.633	1.179
0.25	0.042	2.85	2.828	1.008	0.80	0.134	1.90	1.582	1.201
0.30	0.050	2.73	2.581	1.056	0.85	0.142	1.86	1.534	1.213
0.35	0.058	2.57	2.389	1.076	0.90	0.150	1.85	1.490	1.235
0.40	0.067	2.42	2.238	1.081	0.95	0.158	1.82	1.450	1.255
0.45	0.075	2.30	2.108	1.091	1.00	0.167	1.80	1.414	1.273
0.50	0.084	2.21	2.000	1.105	1.10	0.184	1.75	1.348	1.300
0.55	0.092	2.17	1.906	1.139	1.20	0.200	1.69	1.292	1.310

If the  $k_t$  values from finite element analysis and theory of elasticity [9] is assumed to be exact, then the ratio  $k_t/\bar{k}_t$  may be considered a measure of the error in the estimated value,  $k_t$ . Figure 2 plots this ratio versus the quantity  $r/d$  for each geometry. The quantity  $r/d$  may be considered as a normalized value of the notch radius. From Fig. 2, the estimate  $k_t$  is quite accurate for the sharpest notch, i.e. very small values of  $r/d$ . This estimate involves errors for higher values of  $r/d$ . For the bluntest notches, the error is around 30%. All of the  $k_t/\bar{k}_t$  ratios for  $r/d \leq 0.025$  fall near a single smooth curve, and those for  $r/d > 0.025$  fall above this curve. The curve drawn on Fig. 3 is a representation of the percentage error in calculating the stress concentration factor based on fracture mechanics,  $\bar{k}_t$ , as a function of the ratio  $r/d$ .

Both Figures 2 and 3 may be recommended, therefore, for use in making improved estimates of the factor  $k_t$ . Such estimates are made by first computing the factor  $\bar{k}_t$  from Eq. 7. The error in the estimate of  $k_t$  is then obtained by entering the plot on Fig. 3 with the ratio  $r/d$  for the particular case. The corrected value of  $\bar{k}_t$  may then be calculated using one of the following relationships:

$$\bar{k}_t \text{ (corrected)} = \bar{k}_t \text{ (calculated)} \times \frac{k_t}{\bar{k}_t} \quad (8)$$

$$\bar{k}_t \text{ (corrected)} = \bar{k}_t \text{ (calculated)} \times (1 + \text{error}) \quad (9)$$

The curve in Fig. 2 is expected to apply to most specimen geometries likely to be chosen. However, caution must be exercised if the geometry differs by a large amount from those considered. The curve of Fig.2 should not be extrapolated very far beyond  $r/d = 0.2$ . It should be noted, also, that Fig. 2 implies that no correction to  $k_t$  is needed for  $r/d$  below about 0.025. This is consistent with the expectation that Eq. 1 becomes more accurate for sharper notches.

The corrected value of  $\bar{k}_t$  may be then substituted into Eq. 4 to find an accurate value of the stress Intensity factor,  $K_I$  the critical value of which will represent the material's fracture toughness,  $K_{IC}$ . This is equivalent to calculating the stress Intensity factor,  $K_I$ , from Eq. 5 and then making the necessary correction. A modification to Equation 5 may be made as follows:

$$K_I = \left( \sigma' D^2 / 4d \right)^{1/2} \sqrt{2 \pi (D - d) / (D - 0.8d)} E(r/d) \quad (10)$$

where  $E(r/d)$  is an error correction factor which is a function of the dimensionless notch-tip radius,  $r/d$ . This function is obtained from Fig. 2 and equals  $k_t/\bar{k}_t$ .

## EXPERIMENTAL PROCEDURE

### Materials:

Two structural materials have been used in this study. They are maraging steel and a commercial phosphor bronze. The two materials exhibit rather low ductility. Simple tension tests and hardness measurements have been performed on the test materials and the results are illustrated in Table 2.

Table 2. Mechanical properties of test materials

Material	Modulus of Elasticity, E, Gpa	Yield Stress, $\sigma_y$ , Mpa	Ultimate Stress, $\sigma_u$ , Mpa	% age Elong.	Vickers H. N.
Maraging Steel	205	770	1030	9	360
Phos. bronze	115	350	435	15	137

### Specimens

Small round notched bar specimens have been prepared for fracture toughness testing. Fig. 4: illustrates the specimen configuration and the grip adaptor which makes up for the minimum gripping distance for the tensile testing machine. Various V-notch configurations have been obtained by varying the notch angle and root radius. The notch angle was accurately cut at 30°, 60°, 90°. Due to the difficulty in cutting a notch with a given fine tip radius, the notch tip radii were measured on the notched specimens. The notch depth was adjusted at 2 mm for all specimens.

### Testing Procedure

Prior to plain strain fracture toughness testing, measurements of the strength and ductility of the test materials have been performed. In addition, accurate measurements of the notch tip radius were performed using a Measure-Scope-10. Fig. 5 illustrates the measuring method of the notch tip radius. The notch contour is traced point-by-point by measuring the X and Y coordinates of each point. A smooth curve fitting process is then performed. By drawing a number of chords and mid-point perpendiculars, Fig. 5, the notch tip radius can be determined.

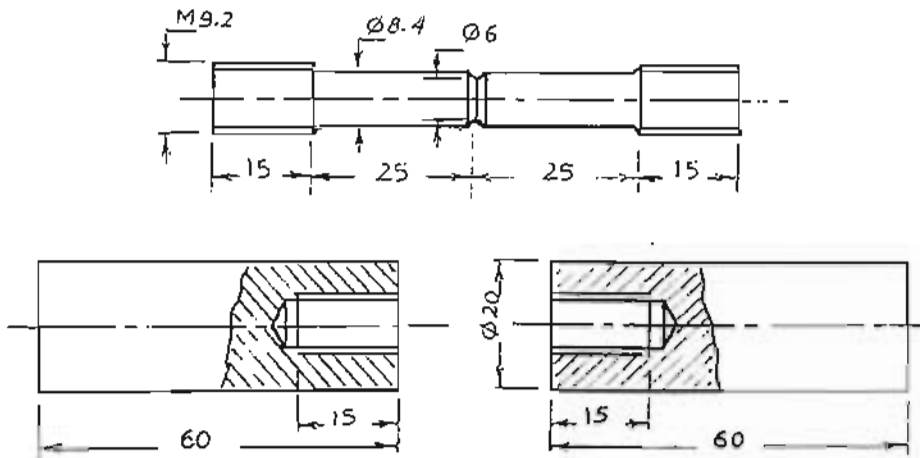

Fig.4 The Fracture Toughness Test Specimen and the Grip Adaptor.

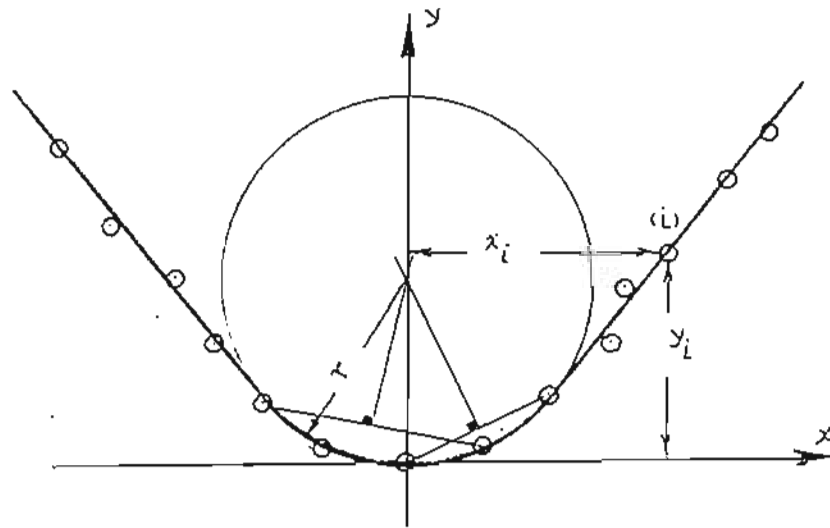

Fig.5 A Schematic Diagram Showing the Method of Tracing the Notch Contour.

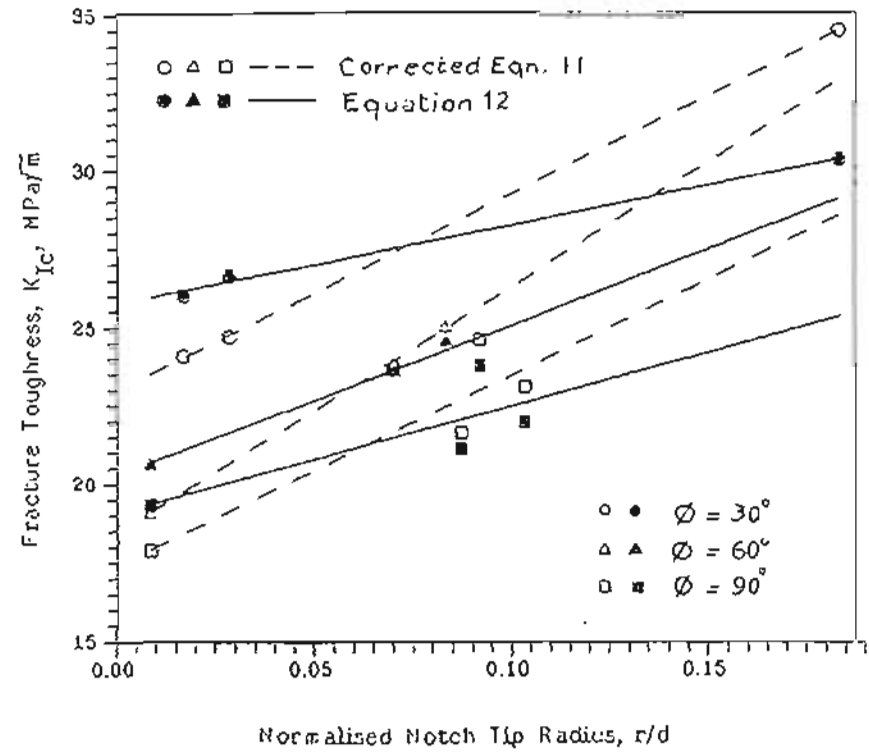

Fig.6 The Variation of Plane Strain Fracture Toughness with the Normalised Notch Tip Radius, r/d for Bronze

For each of the tested materials, a total of (12) twelve specimens having different notch-tip radii ranging from 0.05mm to 1.10mm have been used in this study. Each of the two sets of specimens was divided into three 4-specimens groups having notch angles of 30, 60 and 90 degrees.

Plane strain fracture toughness tests were then performed using a hydraulic universal testing machine Type WPH, VEB, Werkstoff prüfmaschinen, Leipzig. The specimens have been subjected to a gradually applied tensile load till complete fracture was occurred.

## TEST RESULTS AND DISCUSSION

Tables 3 and 4 give summaries of the test results for the two tested materials. The results are illustrated in Figs 6 & 7. The critical value of the stress intensity factor was calculated from Eq. 5 which, upon substituting  $D = 8.4$  mm and  $d = 6$  mm and  $\sigma' = (4P_c / \pi D^2)$ , takes the form:

$$K_{IC} = 13.75 P_c \quad (11)$$

where  $P_c$  is the fracture load in tons.

The graph of Fig. 2 was then used to determine the corrected values of  $K_{IC}$  as shown in Tables 3 and 4.

The values of  $K_{IC}$  calculated from Eq. 9 and corrected using Fig.2 were compared with corresponding values calculated by the exact equation used by Stark [2] which takes the form :

$$K_{IC} = \frac{4P}{\pi D^2} \sqrt{\pi \bar{a}} F ; \quad F = \frac{1.25}{\left[1 - \left(\frac{2\bar{a}}{D}\right)^{1.47} \right]^{2.4}} \quad (12)$$

where  $\bar{a}$  is the crack depth which was set equal to the notch depth in this study. All values of  $K_{IC}$  were tabulated in Tables 3 and 4 and plotted in Figs. 6 and 7.

An examination of Tables 3 and 4 regarding the values of  $K_{IC}$  calculated from Eqs. 11 and 12 demonstrates the existence of a reasonable agreement between the two values; with an error ranging from - 7.66% to +5.43% for  $r/d$  ratios ranging from 0.0065 to 0.137. The error increases to over 13% for  $r/d = 0.183$ . The validity of the present analysis should, therefore, be limited to  $r/d$  ratios below about 0.14 assuming an error of about  $\pm 5\%$  is tolerable. Figs. 6 and 7 show the dependence of the plane strain fracture toughness,  $K_{IC}$ , on the ratio  $r/d$  for the two tested metals.

It can be generally observed that  $K_{IC}$ , which is a measure of the fracture resistance of the material, has a direct relationship with the  $r/d$  ratio. For very sharp notches, the calculated fracture toughness of the material decreases. The calculated fracture toughness becomes higher as the notch-tip radius of the test specimen increases. This finding is considered reasonable since for notches which are not too acute, blunt notches, a triaxial state of stress is generated at the root of the notch. As a result of this triaxial stress state, the general yield stress of the notched specimen becomes greater than the uniaxial yield stress of the material. The reason for this is that the stress triaxiality makes it difficult for the yielded zone to spread through the whole region. The development of tensile stresses in the other two principal directions, see Fig. 1, makes it necessary to raise the axial stress needed to initiate plastic deformation.



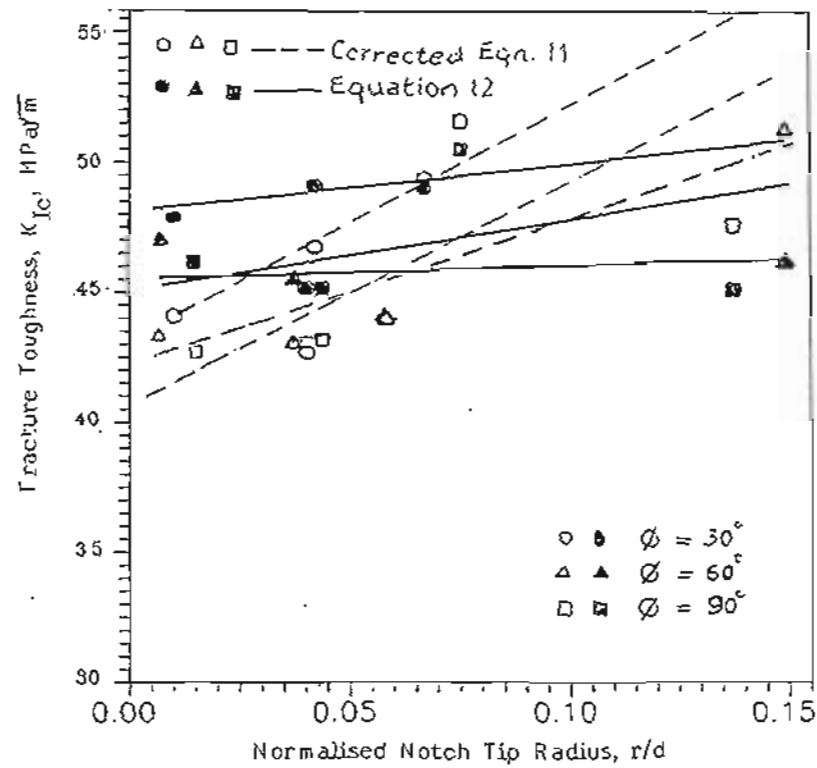

Fig.7 The Variation of Plane Strain Fracture Toughness with the Normalised Notch Tip Radius,  $r/d$ , for Steel

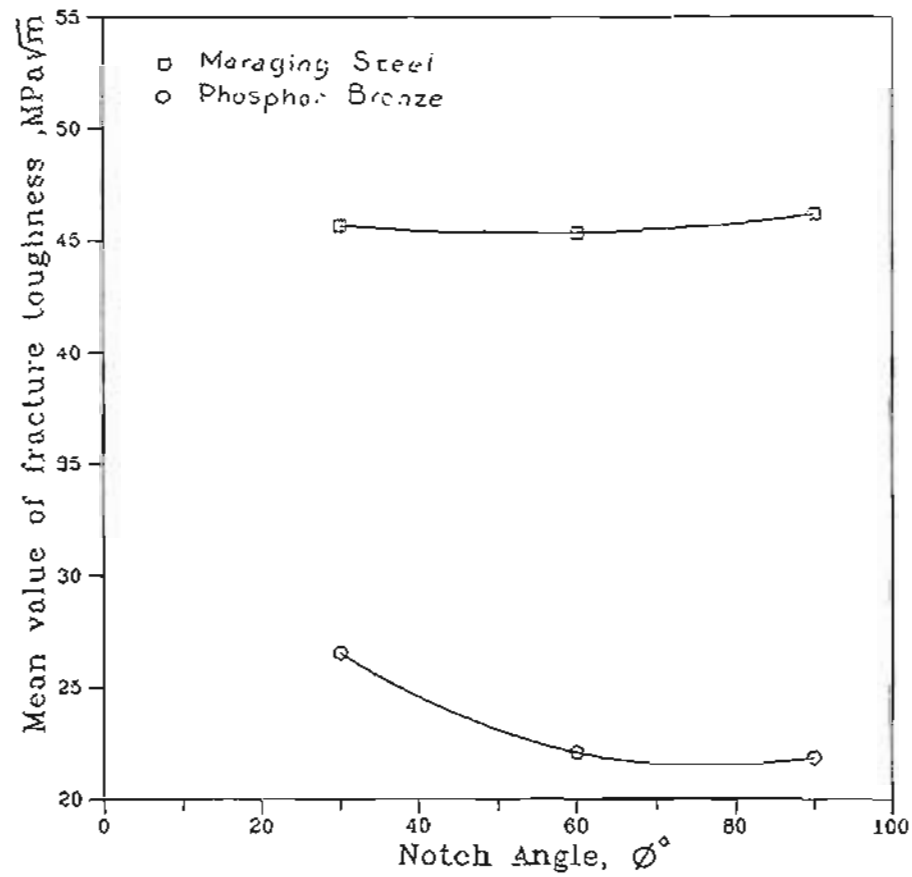

Fig.8 The Variation of Plane Strain Fracture Toughness with the Notch Angle for Bron. and Steel.

Table 3. Experimental Results for Specimens made of Bronze

Specimen No.	Notch Angle, $\phi$	Notch Tip Radius, r, mm	Ratio, r/d	Fracture Load, $P_c$ , KN X 10	Calculated Fracture Toughness, $K_{Ic}$ , $MP_a\sqrt{m}$	Corrected Fracture Toughness, $K_{Ic}$ , $MP_a\sqrt{m}$	Mean Value of fracture toughness, $MP_a\sqrt{m}$	Standard Deviation	Fracture Toughness calculated from Eq.11 $MP_a\sqrt{m}$	% age Error %
1	30°	0.19	0.017	1.75	24.10	24.10	26.56	4.63	26.04	-7.45
2	30°	0.34	0.057	1.55	21.30	22.90			28.64	-7.20
3	30°	1.10	0.183	2.04	28.05	34.50			23.06	-0.70
4	30°								30.36	+13.65
5	60°	0.05	0.008	1.39	19.10	19.10	22.07	2.47	20.68	-7.46
6	60°	0.42	0.070	1.59	21.90	23.87			23.66	+0.90
7	60°	0.45	0.075	1.34	18.40	20.24			19.94	+1.50
8	60°	0.50	0.083	1.65	22.69	25.07			24.55	+2.12
9	90°	0.05	0.008	1.30	17.90	17.90	21.84	2.51	19.34	-7.40
10	90°	0.52	0.087	1.42	19.50	21.65			21.13	+2.46
11	90°	0.55	0.092	1.60	22.00	24.64			23.81	+3.49
12	90°	0.62	0.103	1.48	20.40	23.15			22.02	+5.13

Table 4. Experimental Results for Specimens made of Steel

Specimen No.	Notch Angle, $\phi$	Notch Tip Radius, r, mm	Ratio, r/d	Fracture Load, $P_c$ , KN X 10	Calculated Fracture Toughness, $K_{Ic}$ , $MP_a\sqrt{m}$	Corrected Fracture Toughness, $K_{Ic}$ , $MP_a\sqrt{m}$	Mean Value of Fracture toughness, $K_{Ic}$ , $MP_a\sqrt{m}$	Standard Deviation	Fracture Toughness from Eq.11 $MP_a\sqrt{m}$	% age Error %
1	30°	0.06	0.010	3.21	44.10	44.10	45.64	2.555	47.76	-7.66
2	30°	0.24	0.040	3.02	41.50	42.54			44.94	-5.36
3	30°	0.25	0.042	3.30	45.40	46.65			49.10	-6.99
4	30°	0.40	0.067	3.30	45.40	49.26			49.10	+0.33
5	60°	0.04	0.007	3.15	43.30	43.30	45.31	3.37	46.87	-7.62
6	60°	0.22	0.037	3.05	41.90	42.95			45.38	-5.35
7	60°	0.35	0.058	2.95	40.60	43.85			43.90	-0.23
8	60°	0.90	0.150	3.10	42.60	51.12			46.13	+10.82
9	90°	0.09	0.015	3.10	42.60	42.60	46.14	3.65	46.13	-7.65
10	90°	0.26	0.043	3.03	41.70	42.95			45.09	-4.75
11	90°	0.45	0.075	3.40	46.80	51.48			50.59	+1.76
12	90°	0.82	0.137	3.03	41.70	47.54			45.09	+5.43

On the other hand, very sharp notches tend to embrittle the material at the notch tip. This embrittlement will tend to increase the rate of propagation of the microscopic flaw and reduce the energy needed to cause fracture. Further examination of the results in Tables 3 and 4 indicate that the mean values of  $k_{Ic}$  calculated using the present technique are quite reasonable for these two quasi-brittle materials [10,11]. Figure 8 shows the dependence of the plane strain fracture toughness on the notch angle. It may be observed that the values of  $k_{Ic}$  decrease as the notch angle increases for phosphor bronze. Such dependence is not clear for low-alloy steel. This finding is in agreement with the finding of a finite element analysis made by Kuhne et al. [12,13]. Their theoretical analysis, in addition to a recent experimental analysis [13], concluded that the stress intensification in front of the notch is influenced mainly by the notch radius and that the notch angle has only a minor effect.

### CONCLUSIONS

1. A technique has been presented which allows the use of small notched round bar specimens without precracking for the determination of the plane strain fracture toughness of metallic materials. The technique is based on the linear elastic fracture mechanic analysis. The error inherent in the resulting value of the fracture toughness can then be corrected depending on the ratio of  $r/d$ , a dimensionless notch radius.
2. For very sharp notches, i.e.  $0 \leq r/d \leq 0.025$ , the error encountered in the calculated quantities is about zero. As the ratio  $r/d$  is increased above 0.025, the error increases and reaches about 30% for  $r/d = 0.2$ .
3. For the same applied stress and notch angle, the fracture toughness of the tested materials are found to increase with the increase in the ratio  $r/d$ .
4. The notch angle was found to have a minor effect on the calculated toughness.
5. Comparison of the  $k_{Ic}$  values calculated in this technique and those calculated in the literature indicated reasonable agreement with a difference between the two values ranging from 0 to 5%. It is recommended that  $r/d$  should not exceed about 0.14 for this difference to stay within acceptable limits.
6. The present technique may be considered relatively fast and economic and indicating a level of accuracy adequate for many practical purposes.

### REFERENCES

1. Standard Method of Test for Plane Strain Fracture Toughness of Metallic Materials, ASTM E399-74, 1974
2. Stark, H.L. and Ibrahim, R.N., "Estimating Fracture Toughness from Small Specimens," Engineering Fracture Mechanics, Vol. 25, No. 4, pp. 395-401, 1986.
3. Wilson, W.K., "Elastic-Plastic Analysis of Blunt Notched CT Specimens and Applications," Transactions of the ASME, Journal of Pressure Vessel Technology, Paper No. 74-PVP-39, pp. 1-6, 1974.
4. Dowling, N.E. and Wilson, W.K., "Results of Elastic Analysis of Bluntly Notched Compact Specimens," Engineering Fracture Mechanics, Vol. 20, No. 3, pp. 569, 1984.
5. Creager, H. and Paris, P.C., "Elastic Field Equations for Blunt Cracks with Reference to Stress Corrosion Cracking," Int.J. of Fracture Mechanics, Vol. 3, No. 4, pp. 247-252, 1967.

6. Paris, P.C. and Sih, G.C., "Stress Analysis of Cracks," Symp. on Fracture Toughness Testing and Its Applications, ASTM-STP 381, 30-83, 1965
7. Harris, D.O., "Stress Intensity Factors for Hollow Circumferentially Notched Round Bars," ASME, Ser. D, J. of Basic Engineering, Vol. 89, No. 1, 1967.
8. Cherepanov, G.P., "Mechanics of Brittle Fracture," McGraw-Hill International Book Co., 1979.
9. Deutschman, A.D., Michels, W.J. and Wilson, C.E., "Machine Design-Theory and Practice," Macmillan Publishing Co., Inc., New York, 1975.
10. Felbeck, D.K. and Atkins, A.G., "Strength and Fracture of Engineering Solids," Prentice-Hall, Inc., Englewood Cliffs, NJ 07632, USA, 1984.
11. Terada, H. and Kakutō, Y., "The Effect of Initial Notch Shape of Compact Specimen on Fatigue pre-Cracking and Fracture Toughness Testing," Engineering Fracture Mechanics, Vol. 16, No.2, pp. 279-286, 1982.
12. Kuhne, K., Redmer, J. and Dahl, W., "Elastic-Plastic FEM Calculations of the Stress Distribution of Notches with Different Geometry," Engineering Fracture Mechanics, Vol. 15, No.6, pp. 845-855, 1982.
13. Samy, S.M., "A Study of the Mechanical Properties of Aluminum Alloys," M.Sc. Thesis, Faculty of Engineering and Technology, Suez Canal University, 1989.