

12-1-2021

Investigation of Heat Transfer and Fluidization Dynamics around Horizontal Bundle Tube in Fluidized Bed.

Mohamed Sheta

Mechanical Power Engineering Department., Faculty of Engineering., Menoufia University., Egypt.

Follow this and additional works at: <https://mej.researchcommons.org/home>

Recommended Citation

Sheta, Mohamed (2021) "Investigation of Heat Transfer and Fluidization Dynamics around Horizontal Bundle Tube in Fluidized Bed.," *Mansoura Engineering Journal*: Vol. 18 : Iss. 4 , Article 13.

Available at: <https://doi.org/10.21608/bfemu.2021.166377>

This Original Study is brought to you for free and open access by Mansoura Engineering Journal. It has been accepted for inclusion in Mansoura Engineering Journal by an authorized editor of Mansoura Engineering Journal. For more information, please contact mej@mans.edu.eg.

INVESTIGATION OF HEAT TRANSFER AND FLUIDIZATION DYNAMICS
AROUND HORIZONTAL BUNDLE TUBE IN FLUIDIZED BED

By

M.M. Sheta

Mech. Power Eng. Faculty of Eng. Menoufia Univ.

"دراسة انتقال الحرارة والتميع الديناميكي حول مجموعة من الانابيب الالقية لى
الوسادة المميعة"

الخلاصة : حالة انتقال الحرارة على مجموعة من الانابيب داخل الخوازيق ذات الوسادة المميعة
بتلزم الكثير لبيان التميع الديناميكي على معامل انتقال الحرارة .

بحتى المحدث دراسة خصائص انتقال الحرارة والتميع الديناميكي حول حزمة من الانابيب
الافقية حطية التوزيع موضوعة في مهد مميح . اجريت التجارب على موديل ذو الوسادة المميعة بمقطع عرضي
80x85مم مع استخدام الهواء كوسط للتميع وثلاثة مجموعات من حبيبات الرمل بمنوط اقطار مختلفة .
والنتائج التي حصلنا عليها لمعامل انتقال الحرارة والتميع الديناميكي كدالة مع ارتفاع الوسادة المميعة وقطر
حبيبات الرمل ومعدل الهواء المستهلك دونت في صورة رقم نوسلت، ومعامل مقاومة التميع الديناميكي
كدالة مع بعض المتغيرات المقترحة والملائمة للدراسة . والنتائج التي حصلنا عليها قورنت مع بعض
التجارب النظرية والمعطيه ووجد التوافق بينهما .

ABSTRACT

Experiments were performed on a fluidized bed model with a cross section of 80*85mm² and a height of 1.2m. Sand particles were used as a bed material. Measurements of specific air consumption, pressure drop, mean wall temperature, bed temperature distributions and particle sizes have been carried out. Some primary experiments were carried out at ambient temperature to study fluidization characteristics of sand particles. The measurements were taken at near room temperature and ambient pressure using three sand particle sizes ($d_p = 2.32, 1.60, 1.10\text{mm}$). Experimental results for heat transfer coefficient and aerodynamic characteristics between immersed bundles of horizontal smooth tubes and air-fluidized beds as medium and different particle sizes were reported. The results were presented as a function of specific air consumption, bed height and bed particle diameter. Empirical equations correlating the pertinent variables has been suggested. The obtained data were compared with experimental results and theoretical models from literature.

1. INTRODUCTION

Heat transfer between the fluidized bed and internal or external surfaces has been a subject of research worldwide for around 40 years. The main reason for this is the development of new technologies with fluidized beds such as fluidized bed combustion of coal, fluidized bed cooling towers and heat exchangers and others.

The remarkable features of fluidized bed combustion are excellent heat and mass transfer, the temperature uniformity in the bed, the insensitivity to coal grade, and the effective pollution control. Thanks to the specific properties of the fluidized bed, that the heat transfer coefficient of the fluidization fluid is considerable better than that achieved in the pure stream [1,2]. This has encouraged considerable interest in the study of bed to immersed tube heat exchanger.

Heat transfer in a fluidized bed is a solid-to-solid heat transfer, which is much efficient than a gas-to-solid heat transfer. The friction action of high temperature particles imparts the particles heat rapidly to the cooler surface. As a result of this, there is a greater heat absorption than in a conventional boiler. The total surface required for equal heat transfer rates with a conventional boiler, is less if in-bed tubes are presented [3]. An impetus is given to the development of fluidized bed combustion by recognition that heat exchanger surfaces immersed in the bed enable good control of the bed temperature to be achieved without any determine effect upon mixing, i.e. solid recirculation in the bed [4].

The advantages of heat transfer coefficient, in the existence of fluidized beds at the contact surfaces with them have been widely recognized for quite some time, but the reliable prediction of these coefficients has remained an elusive goal despite the efforts of many investigators [5,6]. In certain applications, most notably atmospheric fluidized bed combustors, banks of horizontal tubes are the most practical heat exchange surfaces available for control of bed temperature by the removal of heat.

In this work, the basic parameters for the design and operation of an atmospheric fluidized bed system are identified, to study the hydrodynamics, thermodynamics and heat transfer processes in the system. Experimental results of the model are presented, and the effects of the different variable on the design and performance of the atmospheric fluidized bed are investigated. The effect of radiation on the heat transfer process is not considered in this work due to the low bed temperatures ($T_b < 50^\circ\text{C}$).

2-Design of Heat Transfer Section

The equipment used in the experimental study is schematically represented in Fig.(1). It consists mainly of a fluidi-

zation shell ($80 \times 85 \text{mm}^2$) of height 1.2m, made of aviation plywood whose inner surface is varnished .

The heat transfer section, consists of in-line parallel horizontal tubes of slightly shorter length than the bed dimension .

The tube boards (made of chip boards) are inserted flush with the wall of the fluidization shell, while the holes in the wall of the tube boards are roughly filled with plasticine to prevent leakage, the assembly of the bundle and the boards is rigid and can be removed easily from the fluidization shell. The fluidization shell allows the cold air to flow externally with respect to the tube bundle by the aid of a gas distributor plate.

Gas distributor plate was made of cloth with an average bore size of 10 micron placed between two metal plates with many coaxial holes of 1.5mm diameter. The air, which acting as the fluidization fluid, is delivered from a compressor and its quantity is regulated by means of a hand driven throttle valve. The flow rate is measured with an orifice plate and a liquid level manometer .

The particular pressure drops in the fluidized bed are measured using a number of pressure probes on the test section and a multi-tube manometer as shown in Fig.(1). Pressure probes are made of small copper tubes of 3mm inside diameter and 65mm long. The pressure drop through the bed is measured using two probes, one at an axial distance of 2mm and the other at 600mm above the distributor plate. The first probe is put in an inclined position with angle of 75° to the horizontal plane, and the other is at a height sufficient to be above the expanded bed. Total pressure drop, i.e. sum of the distributor pressure drop and the bed pressure ,is measured by using two probes, one at 20mm below the distributor plate and the other at 600mm above it. The difference between the total pressure drop and the bed pressure drop gives the pressure drop through the distributor plate.

Bed temperature is an important factor for fluidized bed system. Stability of measurements of heat transfer depends on the bed temperature. Two thermocouples are used to measure the bed temperatures before and after the tube bundle. The thermocouples are constructed to be movable in the radial direction through the bed wall. The thermocouples are made of chromel allumel of 0.5mm diameter.

The external mean surface temperature of the tube bundle was measured with chromel-allumel thermocouples of 0.3mm diameter, three thermocouples were inserted in the tube along with the central couple and then brought through a groove to the surface of the tube at the equator. Its junction was flushed with the surface of the tube and the groove was filled with solder, all thermocouples were brought to the tube through its inner diameter. Thermocouples are located at equal distances on one heated tube as shown in Fig.(2).

The heated tube ,was made of stainless steel with outer diameter of 6mm ,the active length of the heated tube is 80mm in order to avoid the influence of the wall .Teflon seals were placed at both sides to reduce axial heat loss. An (AC) power supply with voltage regulator was used to energize the heater.

The mean surface temperature of the heated tube was calculated as a mean value of twelfth measurements of the tube surface temperatures, which can be obtained by rotating heated tube in 0° , 45° , 90° , 135° along the axial direction . The heated tube could change place with any tube in the bundle to measure the mean value of surface temperature of the tube bundle.

3. Experimental Set Up And METHODS

Preliminary, three different particle size groups of sand are selected by separating particles to the following ranges (1400-850), (2000-1400) and (2800-2000) micron. More accurate sieving analysis is operated again for each group.

The experimental procedure was as follows: first, the tube bundle was formed by placing the tubes in the desired places, five rows of tubes could be formed then the bed material (sand) of certain size was poured up to a certain fixed height, the compressor is then started and the air flow is regulated so that the velocity was at least twice greater than the minimum fluidizing velocity. The heated tube is then turned on and its power is regulated until reached the steady state.

Bed temperatures near the surface of the heated tube and before tube bundle were calculated as a mean value of five measurements of bed temperature at different positions all relevant heat transfer related data then registered. The air flow is decreased and a new steady state is awaited.

The thermophysical properties of the fluidizing gas in the bed μ_g and λ_g and other properties included in the next section of the analysis are taken ,simply , as those for air at the uniform bed temperature. All properties of air are calculated at mean value of air temperature in the bed $T_{b,m}$.

$$T_{b,m} = (T_{b,i} + T_{b,o}) / 2 \quad (1)$$

In general the heat transfer to horizontal tubes in a gas-fluidized bed is described by an overall equation expressing that the heat transfer rate (Q) is proportional to the temperature difference between wall and bed core taking into account a transfer area (A).

$$Q = \alpha A (T_w - T_b) \quad (2)$$

The proportionality factor is usually called the heat transfer coefficient (α). The overall heat transfer coefficient between an immersed bundle of horizontal tubes is

measured by the place of the heated tube with the other tubes in each position in the tube bundle .

All experiments were carried out with an in-line tube bundle . Table (1), shows the parameters of the tube bundle which have been used in obtaining the experimental data .

Ext. diameter of the tube, mm	Number of tubes, %	Tube length in mm, L	Pitches		No. of rows	
			s_1/d_1	s_2/d_1	Z_1	Z_2
6	25	80	2	2	5	5

Table(1) Parameters of the in-line tube bundle

4. RESULTS AND DISCUSSION

Experiments are performed on a fluidized bed model to study the hydrodynamics and heat transfer. The test runs were classified as:-

1- Cold flow tests ,included the investigation of the effects of bed material and packed bed height or weight on the fluidization characteristics and regimes .

2- Hot flow test to study the heat transfer under steady heating of air-fluidized bed acting as fluidized bed heat exchanger for the bed material as a storage medium for energy.

4.1 Cold Flow Test-Results And Discussion

The values of the bed resistance coefficient tends to be practically invariant with specific air consumption (or Reynolds number) and the bed pressure drop behaviour in the bed.

The bed resistance coefficient can be expressed as:

$$\xi = 2 \Delta P_b / \rho q^{*2} \quad (3)$$

$$\xi = 2 Eu \quad (4)$$

Euler number as a function of Reynolds number, bed particle size, bed height and shell bed diameter are used to find the bed resistance coefficient on a model. Then, the aerodynamics experimental data were processed according to the dimensional analysis made by the author relation:

$$\xi \frac{q_{mf}^*}{q} = K Re_p^n \left(\frac{d_t}{d_p} \right)^{n1} \left(\frac{H}{D} \right)^{n2} \quad (5)$$

Figs.(3-4) show the variation of $\xi q^*/q^*$ as a function of Reynolds number in logarithmic coordinates, it was found that the bed resistance coefficient is directly proportional with the bed size and bed height. The difference appeared in the results is due to the effect of the bed static pressure drop

Δp_b and the total weight of the bed material on the bed resistance coefficient.

Also, it is found from these figures that the average value of the exponent n is equal to 1.55, which depends on bed diameter and bed height. For constant values of Re_p , the variation of $\zeta \frac{q^*}{q_{mf}^*}$ with d_t/d_p and H/D was determined, and the average values for n_1 and n_2 was found.

By substituting the values of Re_p , d_t , d_p , D , Re_p , q_{mf}^* , q^* and, H in equation (5), the values of the constant K were determined, and their average value was computed to give the following final correlation:

$$\xi = 0.915 \frac{q^*}{q_{mf}^*} Re_p^{1.55} \left(\frac{d_t}{d_p} \right)^{0.15} \left(\frac{H}{D} \right)^{0.35} \quad (6)$$

Equation (6) includes the bed resistance coefficient for a horizontal tube bundle. The values of the bed resistance coefficient tends to be practically invariant with Reynolds number and the bed height, but it decreases with the increase in the bed particle size.

The percentage error of the experimental data from those computed by this correlation was found to be within 8%.

4.2 Hot Flow Test-Results And Discussion

Results for average heat transfer coefficient in the case of tube bundle as a function of specific air consumption are given in Fig.(5-6). The heat transfer rate decreases with the decrease of bed height and with increase of the bed particle diameter. It can be seen also that, the heat transfer coefficient decreases as the bed particle diameter increases, but the decrease is smaller for particle diameter of $d_p=2.32\text{mm}$. The uncertainty in the present experimental results of heat transfer in case of the tube bundle in fluidized bed is found within 4%.

Figs.(7-8) show the variation of $Nu_p \frac{q^*}{q_{mf}^*}$ with Re_p on log-log coordinates where both the Nusselt number and Reynolds number were based on particle diameter. It is observed that the Nusselt number increases with the increase in Reynolds number and bed height, but it decreases with the increase in the particle size. The average slope of the curves was found to be 1.105.

For constant values of Re_p the variation of $Nu_p \frac{q^*}{q_{mf}^*}$ with d_t/d_p and H/D has been plotted on log-log coordinates. The slope of the curves were found, and the following functional relationship was thus obtained:

$$Nu_p \frac{q^*}{q_{mf}^*} = C \left(\frac{d_t}{d_p} \right)^{0.095} Re_p^{1.075} \left(\frac{H}{D} \right)^{0.03} Pr_g^{0.33} \quad (7)$$

By substituting the values of Nu_p , $q_{m,r}^*$, q^* , d_t , d_p , D , Re_p and Pr_g in the above equation, the value of the constant C is determined, and its average is computed to give the following final correlation :

$$Nu_p = 0.067 \frac{q_{m,r}^*}{q^*} \left(\frac{d_t}{d_p} \right)^{0.095} Re_p^{1.075} \left(\frac{H}{D} \right)^{0.03} Pr_g^{0.33} \quad (8)$$

The percentage deviation of the experimental values from those computed by this correlation was found to be within 15%.

The influence of various parameters on maximum heat transfer coefficient is shown in Fig.(9). It can be seen that the maximum heat transfer coefficient decreases as the bed height decreases and that the decrease is more pronounced in the case of large particle diameter $d_p=2.32\text{mm}$, possibly because particle convection, which is hindered due to the presence of a tube bundle, becomes then less significant. Also, the experiments with the bundle tube have been shown that the maximum heat transfer coefficient in a bed height of 120mm is partially identical, the heat transfer rate decreases as the bed height decrease and being independent of the bed particle diameter.

The present experimental data on maximum heat transfer coefficient of the tube bundle in a fluidized bed of different particle diameters (1.10, 1.60 and 2.32mm) are plotted in Fig.(10), where the values of maximum Nusselt number versus Archimedes number are presented, and have been correlated by the following relation :-

$$Nu_p^{\max} = 0.206 Ar^{0.27} Pr_g^{0.33} \quad (9)$$

Where the particle archimedes and Nusselt number are defined as :

$$Ar = \frac{g d_p^3 \rho_g (\rho_p - \rho_g)}{\mu_g^2} \quad (10)$$

$$Nu_p^{\max} = \frac{\alpha_{g,\max} d_p}{\lambda_g} \quad (11)$$

Equation (9) includes the dimensionless heat transfer coefficient for a horizontal tube bundle which allows for the effect of the particles and gas properties on the maximum heat transfer rate. This correlation has been obtained at $5.10^4 < Ar < 4.5.10^5$ and $35 < Re_p < 155$, with a mean approximation error of 5%.

A comparison between the present experimental results and the data of Catipovic [7] and Gelperin et al [8] in the case of a tube bundle is shown in Fig.(11). Data from literature were taken for sand particle in the same size range fluidized by air at near ambient temperatures. It can be seen that there are noticeable differences in the range $d_p > 1400\mu\text{m}$ of sand

particles sizes the agreement is, with Catipovic [7]. Also, it is found that the correlation of Gelperin and other[8] gives a good fit to this paper's data in the range $d_p < 1400\mu\text{m}$ of sand particle sizes.

5. CONCLUSIONS

Based on the experimental results, the following conclusions may be stated :-

The resistance coefficient of particles in the fluidized state is increased, regardless of Reynolds number or specific air consumption. The bed resistance coefficient across the bed appears to be increased rather independent of the bed height and sizes. Increasing of available bed resistance within the fluidized bed is important to improve heat transfer characteristics .

The heat transfer coefficient records a good improvement with increasing of bed height, whereas it has a significant drop with higher specific air consumption.

From the fact that heat transfer coefficient is varied for $d_p=1.10\text{mm}$ from 127 to 184 $\text{w/m}^2\text{k}$, $d_p=1.60\text{mm}$ from 100 to 175 $\text{w/m}^2\text{k}$ and $d_p=2.32\text{mm}$ from 66 to 156 $\text{w/m}^2\text{k}$, it can be concluded that the influence of the parameters that were varied in this paper decreases as the particle size increases . It is somewhat surprising that bed height is the most important parameter in this particle size range.

Examining also the values of maximum heat transfer coefficient in the bed, α (bed-to-tubes) was found to range from 156 to 184 $\text{w/m}^2\text{k}$ which is equivalent to 2-8 times that for forced convection between pure hot gases and similar tube and bed material. Also, it was found that the correlation of Gelperin and other[8] gives a good fit to this paper's data in the range $d_p < 1400\mu\text{m}$ of sand particle sizes.

6. NOMENCLATURE

A	Surface area of heated tube	m^2
a	Thermal diffusivity	m^2/sec
D	Equivalent shell diameter	m
d	Diameter	m
H	Bed height	m
g	Gravitational acceleration	(9.81 m/sec^2)
λ	Thermal conductivity	$\text{W}/\text{m k}$
Q	The heat transfer rate	W
q^*	Specific air consumption	$\text{m}^3/\text{m}^2\text{sec}$
T	Temperature	($^{\circ}\text{C}$, K)
α	Heat transfer coefficient	$\text{W}/\text{m}^2\text{k}$
Δp	Pressure drop	N/m^2
μ	Dynamic viscosity	$\text{N sec}/\text{m}^2$
ν	Kinematic viscosity	m^2/sec
ρ	Density	kg/m^3
ζ	Resistance coefficient	

6.1 SUBSCRIPTS

b	Bed
g	Gas
i	Inlet
m	Mean
mf	Minimum fluidization
o	Outlet
p	Particle
t	Tube
w	Wall
max	Maximum

6.2 DIMENSIONLESS GROUPS

Ar	Archimedes Number	$(Ar = \frac{g d_p^3 \rho_g (\rho_p - \rho_g)}{\mu_g^2})$
Nu _p	Nusselt Number	$(Nu_p = \frac{\alpha_g d_p}{\lambda_g})$
Re _p	Reynolds number	$(Re_p = \frac{q \cdot d_p}{\nu_g})$
Pr _g	Prandtle Number	$(Pr_g = \nu_g / a_g)$

7. REFERENCES

- 1- Wohlfart A., Int. Symp. on two phase systems, Haifa, P.44,5, Sept. 1971.
- 2- Kobasko N.I., M.D. Kasianova "Izucenie Nekotorij Osebenostei Nestacionarnogo Teploobmena Pri Zakalke "Inst. Techniceskoj Teplofiziki , Akad.Nauk , Moscow, 1975.
- 3- Leslic. Wilbur M.S. , Fellow R.E. and ASME , Handbook of energy System Engineering, P.774, 1985.
- 4- Beer J.M. "The Fluidized Combustion of Coal" 16th., Symp. (International) on Combustion, The Combustion Inst., P.437, 1977.
- 5- Decker N.A. "Heat Transfer to Horizontal Tubes in Large Particle Gas-fluidized Bed" , Sc. D. Thesis, Dep. of Mech. Eng., MIT, Cambridge , MA , 1983.
- 6- Martin H. , "Fluid Bed Heat Exchanger" , Paper Presented at XIV ICHMT Symposium, Dubrovnik, Yugoslavia, September, 1982.
- 7- Catipovic N.M. "Heat Transfer to Horizontal Tubes In Fluidized Beds "Experiment and Theory, Ph.D Thesis, dept. of Chem.Eng., Oreegon State University , Corvallis , OR , 1979.
- 8- Gelperin N.I. et al " Heat Transfer Between A Fluidized Bed And A Staggered bundle of Horizontal Tubes " Int. Chem. Eng., 9, 1, 1969 .

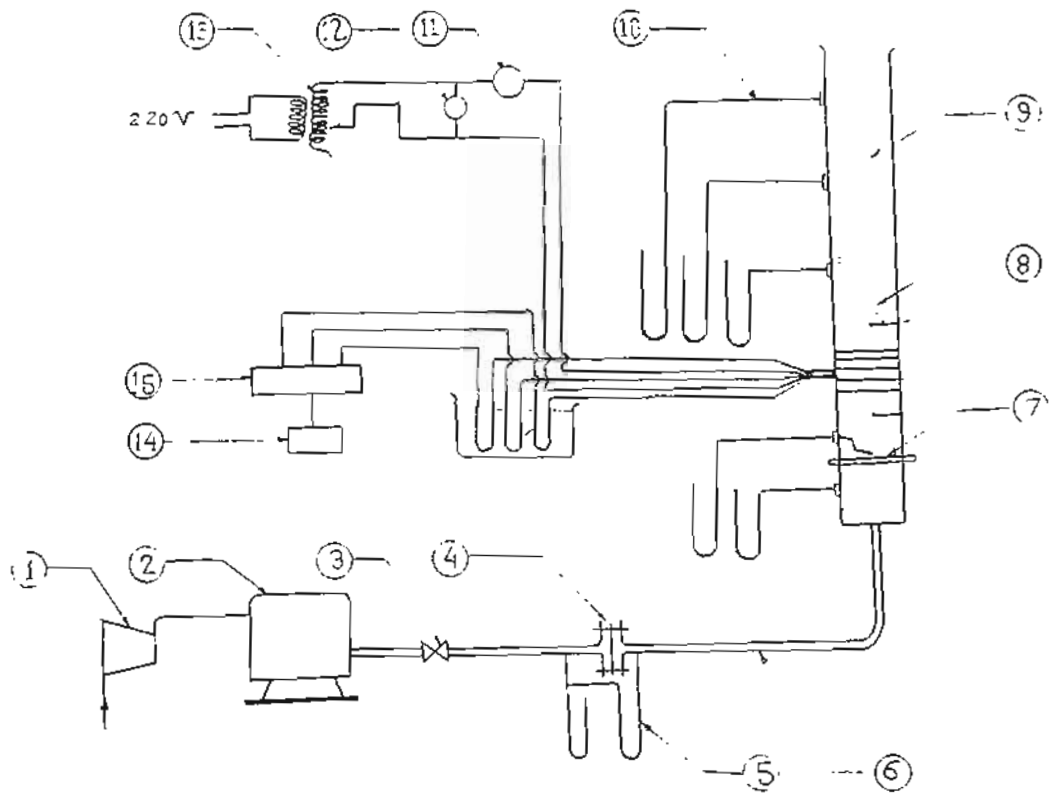

- | | |
|--------------------------------|--------------------------|
| 1- Air compressor | 2- Storage tank |
| 3- Valve | 4- Orifice meter |
| 5- Pressure indication | 6- Delivery pipe |
| 7- Screen (distributor plate) | 8- Fluidized bed section |
| 9- Free board section | 10- Manometers |
| 11- Amperemeter | 12- Voltmeter |
| 13- Variable transformer | 14- Digital Voltmeter |
| 15- Collector of thermocouples | |

Fig. (1) Schematic of the AFB system and auxiliaries .

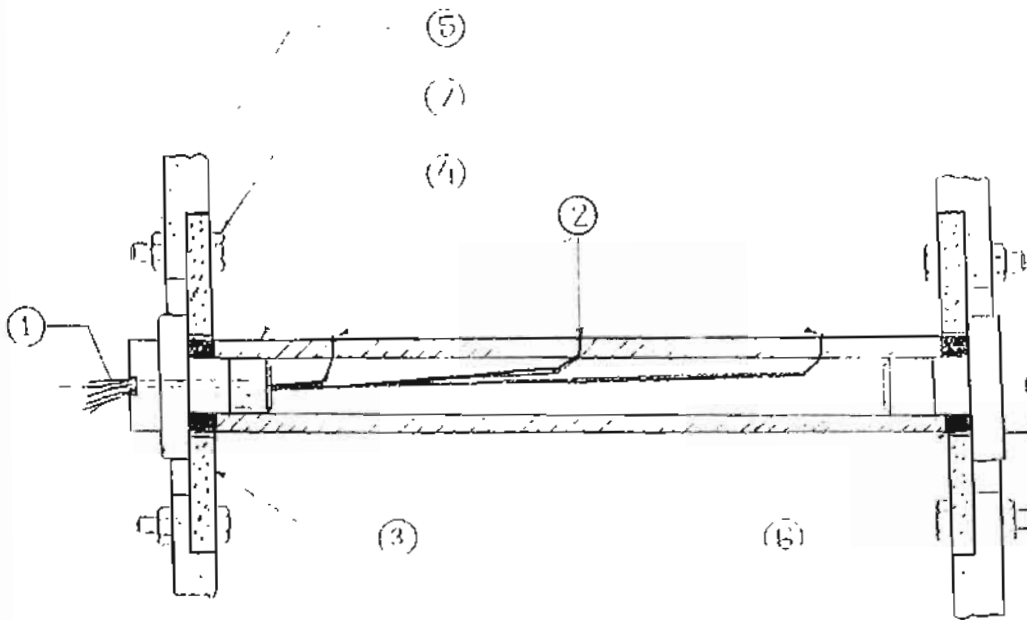

- | | |
|-----------------------|----------------------------|
| 1- Thermocouple wires | 2- Thermocouple junctions. |
| 3- Tube boards | 4- Heated tube |
| 5- shell wall | 6- Teflon seals |
| 7- 4 bolts of M 4. | |

Fig.(2) Details of the heat transfer heated tube .

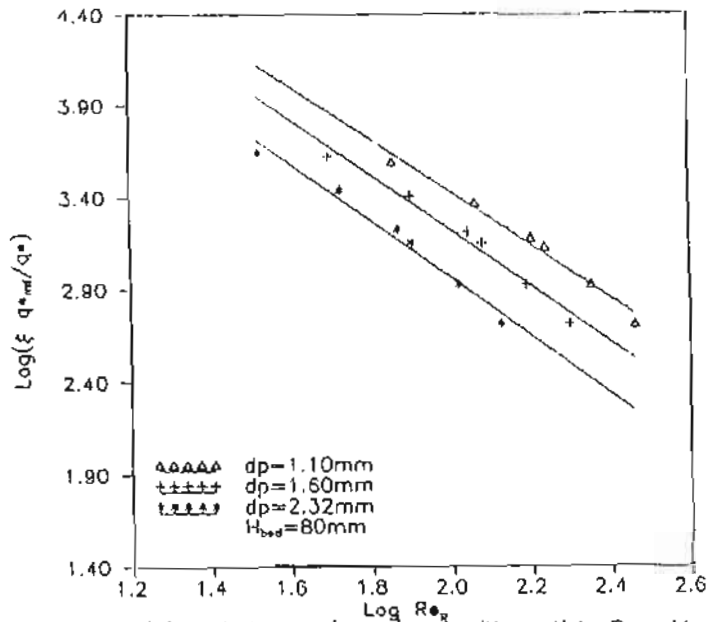

Fig.(3) Variation of $(\xi q^*/q_{*mi}^*)$ with particle Reynolds number (Re_p) for different bed diameter

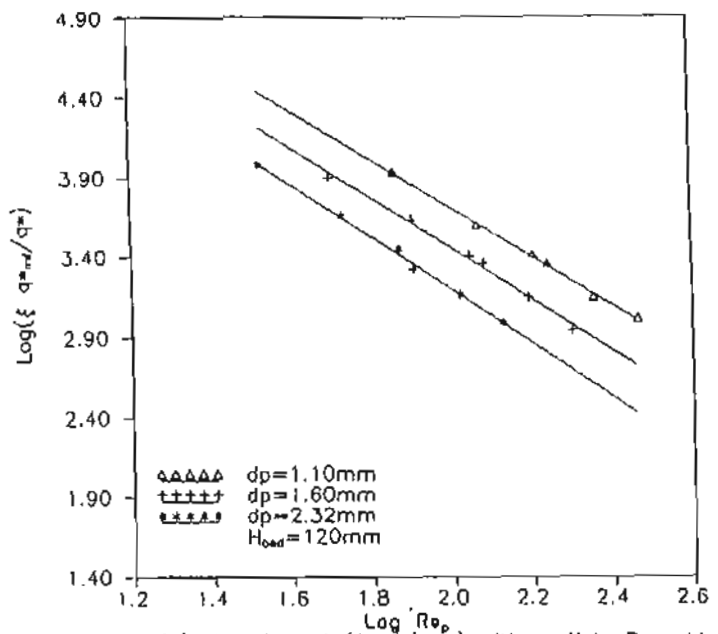

Fig.(4) Variation of $(\xi q^*/q_{*mi}^*)$ with particle Reynolds number (Re_p) for different bed diameter.

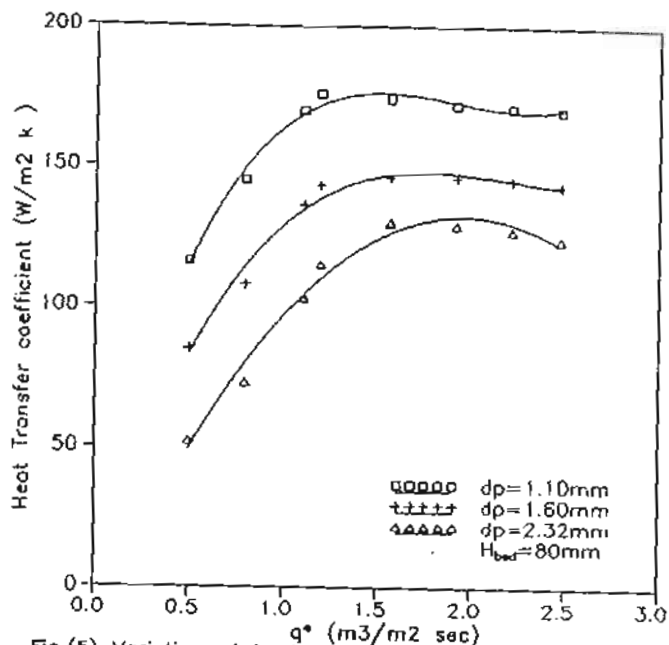

Fig.(5) Variation of heat transfer coefficient with specific air consumption for different bed diameter.

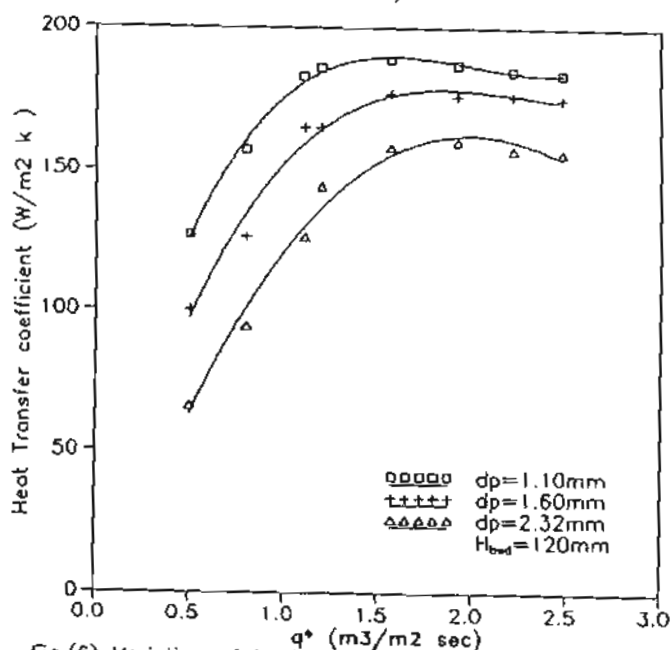

Fig.(6) Variation of heat transfer coefficient with specific air consumption for different bed diameter.

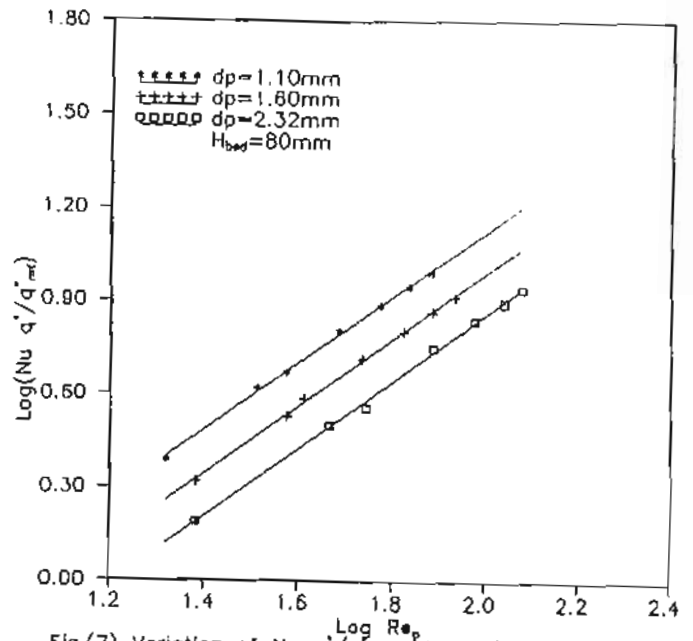

Fig.(7) Variation of $Nu q'/q'_{mf}$ with particle Reynolds number (Re_p) for different bed diameter.

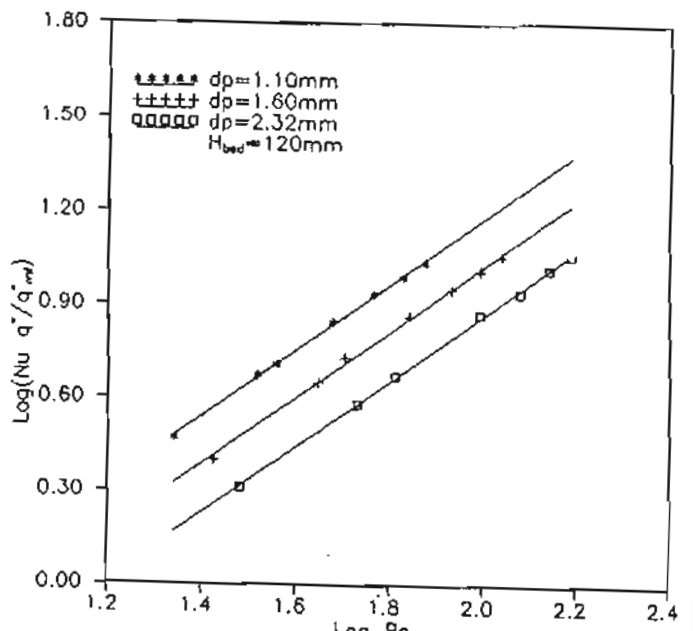

Fig.(8) Variation of $Nu q'/q'_{mf}$ with particle Reynolds number (Re_p) for different bed diameter.

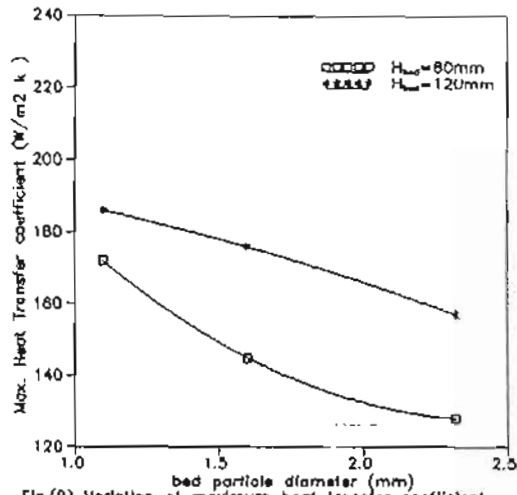

Fig.(9) Variation of maximum heat transfer coefficient with bed diameter for different bed height .

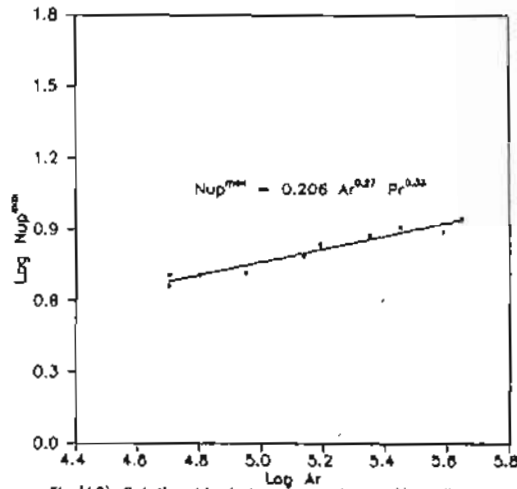

Fig.(10) Relationship between maximum Nusselt number and Archimedes number.

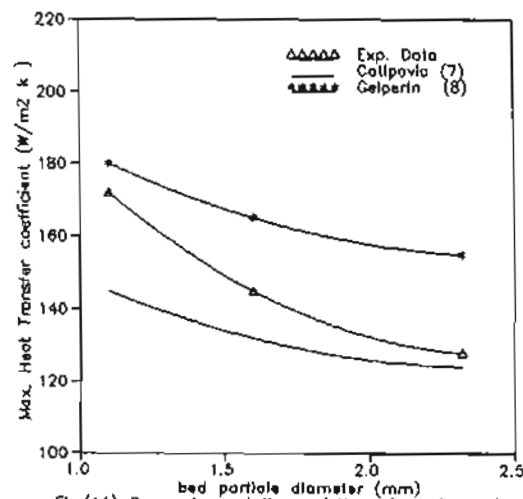

Fig.(11) Comparison of the variation of maximum heat transfer with different bed diameter of H_{bed} = 80mm