

6-1-2021

Geometry of Plain Woven Fabric Made from Flexible Yarns.

Hamdy Ebraheem

Textile Engineering Department., Faculty of Engineering., El-Mansoura University., Mansoura., Egypt.

Follow this and additional works at: <https://mej.researchcommons.org/home>

Recommended Citation

Ebraheem, Hamdy (2021) "Geometry of Plain Woven Fabric Made from Flexible Yarns.," *Mansoura Engineering Journal*: Vol. 20 : Iss. 2 , Article 15.

Available at: <https://doi.org/10.21608/bfemu.2021.161820>

This Original Study is brought to you for free and open access by Mansoura Engineering Journal. It has been accepted for inclusion in Mansoura Engineering Journal by an authorized editor of Mansoura Engineering Journal. For more information, please contact mej@mans.edu.eg.

Geometry of Plain Woven Fabric Made from Flexible Yarns

By: Hamdy A. A. Ebraheem

Lecturer in Textile Engineering Dept., Mansoura University

عنوان البحث: هندسة القماش ذو النسيج السادة المصنوع من خيوط لا تقاوم الإنثناء

ملخص البحث:

يمكننا هذا البحث من حساب زاوية النسيج ، ونسبة تشريب الخيوط ، وكذلك سمك القماش ذو النسيج السادة 1/1 دون الحاجة إلى تسهيل الخيوط ، وقياس نسبة تشريبها على جهاز قياس نسبة التشريب أو سمك القماش . ويلزم لذلك معرفة مواصفتين بسيطتين للقماش ، وهما عدد الخيوط /سم ، وقطر الخيط . وتساعد هذه الطريقة على تجنب تقطيع القماش وإتلافه ، كما توفر الوقت والجهد والمال . وبمعرفة نسب التشريب يمكننا حساب طول الخيط المطلوب ، وتقليل العوادم ، وحساب وزن المتر المربع من القماش .

I- Abstract:

This paper gives accurate methods to calculate weave angle, yarn crimp ratio, and fabric thickness in a plain-woven fabric. Two simply obtained fabric characteristics are used. These characteristics are yarns / cm i.e ends/cm and picks/cm and yarn diameter for warp and weft. This method can be used instead of using crimp tester or thickness meter. This helps save time, effort, and money and is suitable for expensive fabrics as fabric destroying is avoided. yarn crimp ratio can thus be calculated in advance and the amount of yarn required to weave a certain quantity of fabric can be estimated. Fabric weight can also be calculated. This helps reduce yarn waste to a minimum.

II- Mathematical derivation:

From Peirce's flexible model [1] shown in Fig. (1) the following relations are valid:

$$\text{Putting } d_1 + d_2 = 2D \quad (1)$$

$$\text{then } h_1 + h_2 = 2D \quad (2)$$

From model geometry it can be proved that

$$P_2 = (L_1 - 2D \theta_1) \cos \theta_1 + 2D \sin \theta_1 \quad (3)$$

$$P_1 = (L_2 - 2D \theta_2) \cos \theta_2 + 2D \sin \theta_2 \quad (4)$$

$$h_1 = (L_1 - 2D \theta_1) \sin \theta_1 + 2D (1 - \cos \theta_1) \quad (5)$$

$$h_2 = (L_2 - 2D \theta_2) \sin \theta_2 + 2D (1 - \cos \theta_2) \quad (6)$$

Assuming that the fabric apparent thickness (T) will be equal to $(d_1 + h_1)$ or $(d_2 + h_2)$ whichever is more.

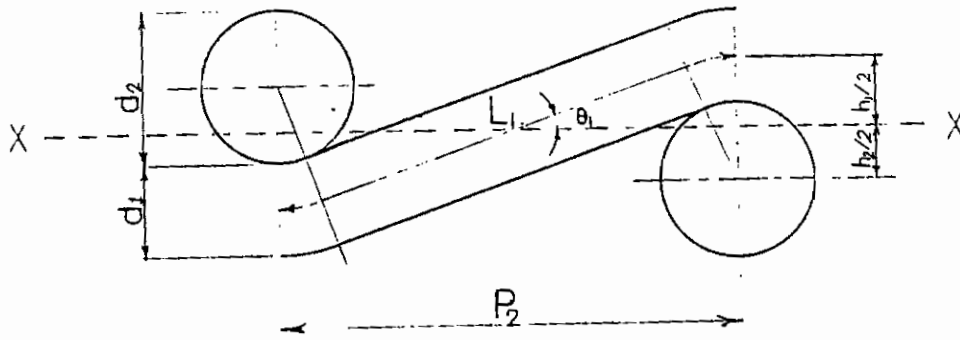

Fig. (1): Peirce's Flexible Model

(Subscripts 1 and 2 for warp and weft respectively, d = yarn diameter, L = modular length, $h/2$ = max. displacement of the yarn axis from the cloth plane, P = yarn spacing, x = cloth plane, θ = angle between yarn axis cloth plane, and D = average yarn diameter = average yarn displacement)

Substituting for h_1 in (5) by $2D - h_2$ and for h_2 in (6) by $2D - h_1$, we obtain

$$L_1 - 2D \theta_1 = 2 \cot \theta_1 \left(D - \frac{h_2}{2} \sec \theta_1 \right) \quad (7)$$

and

$$L_2 - 2D \theta_2 = 2 \cot \theta_2 \left(D - \frac{h_1}{2} \sec \theta_2 \right) \quad (8)$$

Substituting from (7) in (3) and (5) and from (8) in (4) and (6) we get

$$P_2 = \cot \theta_1 \cos \theta_1 (2D - h_2 \sec \theta_1) + 2D \sin \theta_1 \quad (9)$$

$$h_1 = \cot \theta_1 \sin \theta_1 (2D - h_2 \sec \theta_1) + 2D (1 - \cos \theta_1) \quad (10)$$

$$P_1 = \cot \theta_2 \cos \theta_2 (2D - h_1 \sec \theta_2) + 2D \sin \theta_2 \quad (11)$$

$$h_2 = \cot \theta_2 \sin \theta_2 (2D - h_1 \sec \theta_2) + 2D (1 - \cos \theta_2) \quad (12)$$

Multiplying (9) by $\sin \theta_1$ and (10) by $\cos \theta_1$ and comparing both equations we conclude that

$$P_2 \sin \theta_1 = h_1 \cos \theta_1 - 2D \cos \theta_1 + 2D \quad (13)$$

Solving this equation for $\sin \theta_1$ and putting

$$R_1 = \frac{h_1}{2D} \quad \text{and} \quad R_2 = \frac{h_2}{2D} \quad \text{give}$$

$$\sin \theta_1 = \frac{2DP_2 - 2D \sqrt{P_2^2 (1 - R_1)^2 - 4D^2 (2R_1 - 5R_1^2 + 4R_1^3 - R_1^4)}}{P_2^2 + 4D^2 (1 - 2R_1 + R_1^2)}$$

or

$$\sin \theta_1 = \frac{2DP_2 - 2D\sqrt{P_2^2(1-R_1)^2 - 4D^2(2R_1 - 5R_1^2 + 4R_1^3 - R_1^4)}}{P_2^2 + 4D^2(1-R_1)^2} \quad (14)$$

Similarly

$$\sin \theta_2 = \frac{2DP_1 - 2D\sqrt{P_1^2(1-R_2)^2 - 4D^2(2R_2 - 5R_2^2 + 4R_2^3 - R_2^4)}}{P_1^2 + 4D^2(1-R_2)^2} \quad (15)$$

Putting $R_1 = 1 - R_2$ in (14)

$$\therefore \sin \theta_1 = \frac{2DP_2 - 2DR_2\sqrt{P_2^2 - 4D^2(1-R_2^2)}}{P_2^2 + 4D^2R_2^2} \quad (16)$$

Putting $R_2 = 1 - R_1$ in (15)

$$\therefore \sin \theta_2 = \frac{2DP_1 - 2DR_1\sqrt{P_1^2 - 4D^2(1-R_1^2)}}{P_1^2 + 4D^2R_1^2} \quad (17)$$

III- Calculation of Crimp Ratio:

Warp crimp ratio C_1 = and weft crimp ratio C_2 are expressed as follows [2]:

$$C_1 = \frac{L_1 - P_2}{P_2} = \frac{L_1}{P_2} - 1$$

From (3)

$$C_1 = \sec \theta_1 - \frac{2D}{P_2} \tan \theta_1 + \frac{2D}{P_2} \theta_1 - 1 \quad (18)$$

where $\theta_1 < 90^\circ$

Similarly

$$C_2 = \frac{L_2 - P_1}{P_1} = \frac{L_2}{P_1} - 1$$

From (4)

$$C_2 = \sec \theta_2 - \frac{2D}{P_1} \tan \theta_2 + \frac{2D}{P_1} \theta_2 - 1 \quad (19)$$

where $\theta_2 < 90^\circ$

When $\theta_1 = 90^\circ$, $\theta_2 = 0^\circ$, $C_1 = \frac{\pi D}{P_2} - 1$, and $C_2 = 0$

When $\theta_2 = 90^\circ$, $\theta_1 = 0^\circ$, $C_2 = \frac{\pi D}{P_1} - 1$, and $C_1 = 0$

Assuming fabric thickness (T) = $d_1 + d_2$. We find that $T = d_1 + h_1$ and $T = d_2 + h_2$

$$\therefore h_1 = d_2 \quad \text{and} \quad h_2 = d_1$$

$$\text{In this case } R_1 = \frac{h_1}{2D} = \frac{d_2}{2D}$$

$$\text{and } R_2 = \frac{h_2}{2D} = \frac{d_1}{2D}$$

This is the state of fabric after relaxation when laid between to plates. Substituting in equations (16) and (17) gives

$$\sin \theta_1 = \frac{(d_1 + d_2) P_2 - d_1 \sqrt{P_2^2 - d_2(2d_1 + d_2)}}{P_2^2 + d_1^2} \quad (20)$$

and

$$\sin \theta_2 = \frac{(d_1 + d_2) P_1 - d_2 \sqrt{P_1^2 - d_1(2d_2 + d_1)}}{P_1^2 + d_2^2} \quad (21)$$

Yarn diameter d is a function of yds/lb of the yarn and yarn type. Ashenhurst [4] determined empirically a constant for every kind of spun yarns as shown in Table (1). The reciprocal of the product of this constant and square root of yds/lb gives yarn diameter in inches. Based on experimental observation, Peirce [1] derived a formula for cotton yarn diameter in woven fabrics as follows: $d = \frac{1}{28 \sqrt{N}}$, d is in inch and N is English count in cotton system. He assumed that cotton yarn specific volume is $1.1 \text{ cm}^3/\text{gm}$.

Table (1): Ashenhurst's Empirical values of constant (F) used in calculating yarn diameter d (in) = $\frac{1}{F \sqrt{yds/lb}}$:

Yarn type	Cotton	Fine worsted	Woolen	Linen	Crossbred Worsted
Constant (F)	0.92	0.91	0.84	0.92	0.86

IV- Example

$$\begin{aligned} \text{Ends/cm} &= 20 & \therefore P_1 &= 0.05 \text{ cm} \\ \text{Picks/cm} &= 14 & \therefore P_2 &= 0.07 \text{ cm} \\ d_1 &= 0.02 \text{ cm} & , & & d_2 &= 0.03 \text{ cm} \\ \therefore D &= 0.025 \text{ cm} \end{aligned}$$

Table (2) gives the values of weaving angles, crimp ratios, and fabric thickness at different levels of crimp altitudes i.e. at different values

**Table (2): Weave Angles, Crimp Ratios, and Fabric Thickness of Plain Woven Fabric
at Different Levels of Crimp Altitudes:**

	(1)	(2)	(3)	(4)	(5)	(6)	(7)	(8)	(9)	(10)	(11)
R_1	0.0	0.1	0.2	0.3	0.4	0.5	0.6	0.7	0.8	0.9	1.0
R_2	1.0	0.9	0.8	0.7	0.6	0.5	0.4	0.3	0.2	0.1	0.0
θ_1 (degrees)	0.00	4.195	8.584	13.143	17.837	22.62	27.432	32.206	36.87	41.351	45.58
θ_2 (degrees)	90.00	78.578	67.38	56.602	46.397	36.87	28.072	20.016	12.68	6.026	0.00
C_1	0.00	0.00259	0.01052	0.02396	0.043	0.0677	0.0979	0.1334	0.17393	0.218997	0.2681
C_2	0.571	0.4715	0.376	0.2879	0.2098	0.1435	0.08995	0.0493	0.02131	0.005166	0.00
h_1 (cm)	0.00	0.005	0.01	0.015	0.02	0.025	0.03	0.035	0.04	0.045	0.05
h_2 (cm)	0.05	0.045	0.04	0.035	0.03	0.025	0.02	0.015	0.01	0.005	0.00
d_1+h_1 (cm)	0.02	0.025	0.03	0.035	0.04	0.045	0.05	0.055	0.06	0.065	0.07
d_2+h_2 (cm)	0.08	0.075	0.07	0.065	0.06	0.055	0.05	0.045	0.04	0.035	0.03
T(cm)	0.08	0.075	0.07	0.065	0.06	0.055	0.05	0.055	0.06	0.065	0.07

of R_1 and R_2 using equations (16), (17), (18) and (19). From column (7) it is noticed that $R_1 = \frac{d_2}{2D}$ and $R_2 = \frac{d_1}{2D}$. The values in this column describe the previously mentioned special case in which fabric apparent thickness is equal to the sum of warp and weft diameters. It's noticed from the table that the thicker yarn (weft) has a crimp ratio less than that of the thinner one (warp). Figs. (3, 4, and 5) show how weave angle, yarn crimp ratio, and fabric thickness are affected by crimp altitude.

V- Ground of Woven Carpet:

In the ground of woven carpet it is found that weft yarn is greatly thicker and softer than warp ends. Due to high warp tension during weaving and the previously mentioned yarn properties, warp yarns are interlaced with weft yarns as shown in Fig. (2). In this case

$$h_2 = 0, \quad h_1 = d_2 - d_1 \quad \text{and} \quad d_2 - d_1 = 2D$$

$$\therefore R_1 = 1 \quad \text{and} \quad R_2 = 0$$

Substituting in equations (16), (17), (18) and (19) gives

$$\sin \theta_1 = \frac{d_2 - d_1}{P_2} \quad (22)$$

$$\sin \theta_2 = 0 \quad (23)$$

$$C_1 = \sec \theta_1 - \frac{d_2 - d_1}{P_2} \tan \theta_1 + \frac{d_2 - d_1}{P_2} \theta_1 - 1 \quad (24)$$

and

$$C_2 = 0 \quad (25)$$

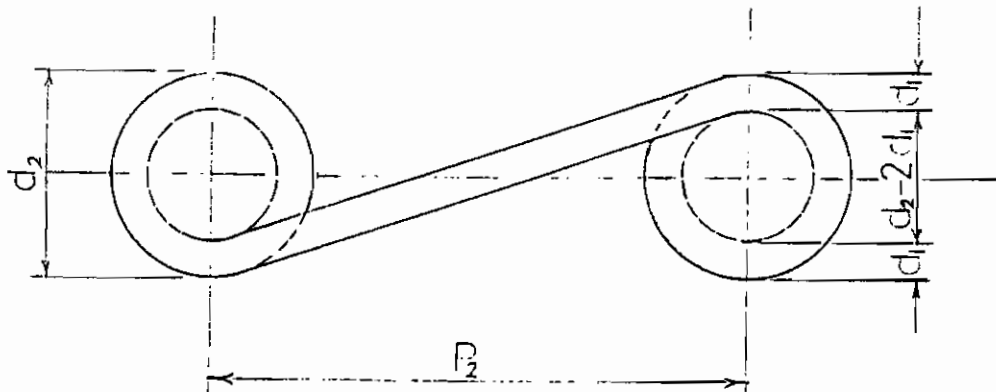

Fig. (2): Interlacing of warp with weft yarns in the ground of woven carpets

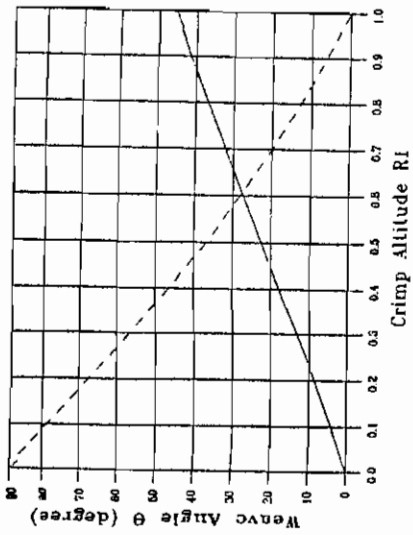

Fig.(3): Effect of Crimp Altitudes on Weave Angle (—Warp, ----weft)

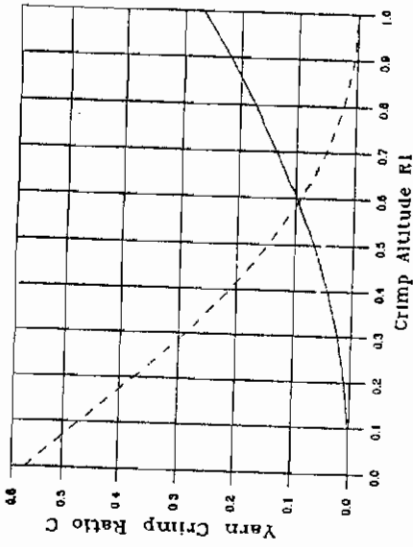

Fig.(4): Effect of Crimp Altitude on Yarn Crimp Ratios (—Warp, ----Weft)

$T=d_1+h_1$ or $T=d_2+h_2$
whichever is more.

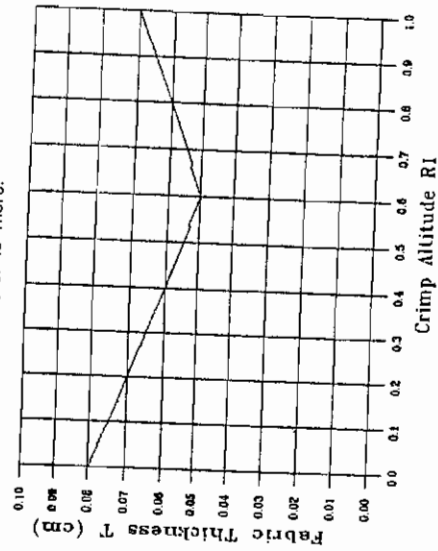

Fig.(5): Effect of Crimp Altitude on Fabric Thickness

VI- Square Plain Woven Fabric:

For square plain woven fabric

$$R_1 = R_2 = 0.5$$

$$d_1 = d_2 = h_1 = h_2 = d$$

$$P_1 = P_2 = P$$

$$\therefore \sin \theta = \frac{2dP - d\sqrt{P^2 - 3d^2}}{P^2 + d^2} \quad (26)$$

and

$$C = \sec \theta - \frac{2d}{P} \tan \theta + \frac{2d}{P} \theta - 1 \quad (27)$$

Denoting $\frac{d}{P}$ as yarn cover ratio K

$$\therefore \sin \theta = \frac{2k - k\sqrt{1 - 3k^2}}{1 + k^2} \quad (28)$$

and

$$C = \sec \theta - 2k \tan \theta + \frac{\pi k \theta}{90} - 1 \quad (29)$$

Table (3) shows the the application of equations (28) and (29). In a previous study [3] the following expressions were obtained:

$$\tan \theta = \frac{2\sqrt{1 - 3k^2}}{(k)\sqrt{1 - 3k^2} + 2k} \quad (30)$$

and

$$C = \sqrt{1 - 3k^2} + \frac{\pi k \theta}{90} - 1 \quad (31)$$

It's worth saying that these expressions are only other forms but they give the same results as those given in Table (3).

Table (3): Effect of yarn cover ratio (k) on weave angle (θ) and yarn crimp ratio (C) in Plain Square Fabric woven from limp threads:

k	θ°	C
0.01	0.573	0.00005
0.03	1.7199	0.00045
0.05	2.8696	0.00125
0.10	5.768	0.00502
0.20	11.784	0.0204
0.30	18.379	0.04686
0.40	26.167	0.0860
0.50	36.87	0.1435
0.55	48.734	0.1820
0.577	60.00	0.2100

VII- Measuring Fabric Geometrical Parameters:

A $\frac{60 \times 60}{20 \times 20}$ /in plain cotton fabric was woven on 3 modern weaving machines: Sulzer Ruti P7100, Rapier Pignone Tp 500, and Tsudakoma Air-Jet. Yarn crimp ratios were measured. Fabric weight was calculated (using measured crimp ratios) and also measured. Ten samples were taken for every test. Table (4) shows the results (mean values) of this experimental study.

Table (4): Results of Experimental study of Fabric Geometrical Parameters.

Parameter	Weaving m/c	Sulzer	Rapier	Air-Jet
Warp crimp ratio		0.10	0.06	0.08
West crimp ratio		0.04	0.06	0.06
Calculated fabric weight (g/m ²)		151.7	150.23	151.47
Measured fabric weight (g/m ²)		171.83	162.32	160.26

It's clear from the table that values are widely different although they describe the same fabric style. This variation may be attributed to:

- 1- The inaccuracy in measuring sample dimensions (length and width).
- 2- The decrimping load during crimp measuring test may be not sufficient to remove yarn crimp. It's worth mentioning that decrimping load (g) is constant for cotton yarns coarser than 7 tex ($0.2 \text{ tex} + 4$).
- 3- The decrimping time is not the same for all samples as it is not of a recommended value.
- 4- Variation of personnel efficiency and accuracy besides fatigue considerations.
- 5- Cumulative errors due to progressive measurements.

If these geometrical parameters are analytically determined using the procedure given in this paper, the following results will be obtained:

Calculated Yarn Weave Angle = 34.17°

Calculated Yarn Crimp Ratio = 0.1296

Calculated Fabric Weight = 157.89 g/m^2

The accuracy of these calculated values depend on the accuracy of measuring yarn diameter and yarn spacing in the fabric.

VIII. Conclusion:

Yarn crimp ratio in the plain woven fabric can be calculated. This needs determining yarn spacing (the reciprocal of yarn density) and yarn diameter for warp and weft. Then weave angles can be calculated and so crimp ratio for both warp and weft. This helps avoid the destructive test required for crimp measuring and achieves the accuracy required to calculate fabric weight and the length of yarn needed to produce a certain amount of fabric.

References

- [1] Peirce, F. T., The Geometry of Cloth Structure, J. Text. Inst., 28, T45-T112, 1937.
- [2] J. E. Booth, Principles of Textile Testing, Newness-Butterworths, 1968, 265-271.
- [3] Hamdy A. A. Ebraheem, Geometry of Plain Square Fabric Woven from Flexible Yarns, Mansoura Engineering Journal, Vol. 19, No. 4, December 1994, T. 13-T. 23.
- [4] Ashenhurst, T. R., Weaving and Designing Textile Fabrics, Broadbend and Co., London, 1885.