

3-20-2021

Forced Convection Heat Transfer from a Cross Yawed Tube with Back Splitter Plate.

F. Araid

Mechanical Power Engineering Department., Faculty of Engineering., El-Mansoura University., Mansura., Egypt.

Follow this and additional works at: <https://mej.researchcommons.org/home>

Recommended Citation

Araid, F. (2021) "Forced Convection Heat Transfer from a Cross Yawed Tube with Back Splitter Plate.," *Mansoura Engineering Journal*: Vol. 25 : Iss. 2 , Article 8.
Available at: <https://doi.org/10.21608/bfemu.2021.157998>

This Original Study is brought to you for free and open access by Mansoura Engineering Journal. It has been accepted for inclusion in Mansoura Engineering Journal by an authorized editor of Mansoura Engineering Journal. For more information, please contact mej@mans.edu.eg.

FORCED CONVECTION HEAT TRANSFER FROM A CROSS-YAWED TUBE WITH BACK SPLITTER PLATE

انتقال الحرارة بالحمل القسري من أنبوبة مستعرضة منحرفة ذات لوح فاصل خلفي

Araid, F. F.

Associate Professor, Mechanical Power Engineering Department
University of El Mansoura, Egypt

الخلاصة:

يتضمن هذا البحث دراسة عملية لانتقال الحرارة بالحمل القسري من أنبوبة نحاسية مستعرضة منحرفة ذات لوح فاصل خلفي. وقد اشتمل البحث على دراسة تأثير تغيير زاوية انحراف الانبوبة من 0° إلى 30° من الوضع العمودي للانبوبة على اتجاه سريان الهواء. وكذلك تم دراسة تأثير تغيير طول اللوح الفاصل المثبت على السطح الخلفي للانبوبة المستعرضة و المثبت على زاوية 180° من نقطة التصدي مع تغيير زاوية انحراف الانبوبة. واثناء التجارب تم تغيير طول اللوح الفاصل من $b=0$ إلى $b=1.5d_0$ مع تغيير سرعة سريان الهواء بحيث يتغير رقم رينولدز من 9500 إلى 54700 وقد أتضح من الدراسة أن انتقال الحرارة بالحمل القسري إلى تيار الهواء الذي يسري عموديا على الأنبوبة يتأثر بتغيير طول اللوح الفاصل الخلفي و زاوية انحراف الانبوبة. وقد استنتج أن أكثر الحالات فعالية على انتقال الحرارة بالحمل القسري إلى تيار الهواء الذي يسري عموديا عليها عندما تكون زاوية الانحراف $\theta = 30^\circ$ وطول اللوح الفاصل $b=0.75d_0$. وقد تم استنتاج علاقة لايعدية بين رقم نوسيلت ورقم رينولدز و برانتل لاستخدامها في حساب معامل انتقال الحرارة بالحمل في هذه الحالة.

ABSTRACT

An experimental investigation has been presented to study the forced convection heat transfer from a cross yawed circular tube with back splitter plate. The course of the experimental work covers Reynolds number range from 9500 to 54700, the wake splitter length varied from $b = 0$ to $1.5d_0$ and the yaw angle of tube changes from 0° to 30° with respect to the cross flow orientation. The obtained results are compared with the available data in the literature. The heat transfer from the yawed tube with splitter plate is fitted as a correlation between the Nusselt, Reynolds and Prandtl numbers. This correlation indicates that the Nusselt number is a significant function of Reynolds number, yaw angle and splitter plate length. It is also seen that the effect of the yaw angle on the convective heat transfer from the tube is less than the effect of the splitter plate length, and the yawed tube with back splitter plate of length $b=0.75d_0$ and $\theta=30^\circ$ has higher results than the other cases. A dimensionless correlation is obtained to calculate the convective heat transfer Nusselt number as a function of yaw angle, splitter plate length, Reynolds number and Prandtl number.

NOMENCLATURE

A	surface area of tube with splitter plate, m^2
b	splitter plate length, m
c_p	specific heat at constant pressure, kJ/kg K
d	tube diameter, m
h	average heat transfer coefficient, W/m^2K
h_{sp}	circumferential local heat transfer coefficient, W/m^2K
k	thermal conductivity, W/mK
l	total assembled length of test tube, m

L	test tube length, m
Nu	average Nusselt number, $h d_o/k$
Nu_{ϕ}	circumferential local Nusselt number, $h_{\phi} d_o/k$
Nu_x	local Nusselt number on the splitter plate, $h_x x/k$
Pr	Prandtl number, $\mu c_p/k$
Q	rate of heat transfer, W
Re	Reynolds number based on the normal free stream velocity to the yawed tube, $Re \cos \theta$
Re^*	Reynolds number based on the corrected velocity, $v^* d_o/\nu$
T	temperature, °C
v	free stream velocity, m/s
v^*	corrected free stream velocity, $1.05 v$, m/s, equation (10)
θ	yaw angle of tube with respect to the cross position, degree
Φ	circumferential angle, measured from the forward stagnation line, degree
μ	dynamic viscosity, Ns/m^2
ν	kinematic viscosity, m^2/s
ρ	air density, kg/m^3

Subscripts

i	inside
m	average value
o	outside
p	projected
s	surface
x	local
ϕ	circumferential local
∞	ambient

INTRODUCTION

The exploitation of high performance heat exchangers for saving and making effective use of energy is a very important problem. So, the evaluation of heat transfer is an important step in the design and performance analysis of many types of heat exchangers. Therefore, the investigation of the heat transfer from tubes in cross flow is still of great practical interest. The effect of tube shape on heat exchanger characteristics have received much attention by many investigators.

Heat transfer from a tube in cross flow has been the subject of many experimental and theoretical investigations because of its numerous engineering applications [1-5].

The total and local heat transfer from a smooth circular cylinder to the cross flow of air has been measured over the Reynolds number range from 3×10^4 to 4×10^6 by Elmar [6]. The interaction between flow and heat transfer has been discussed.

Heat transfer and flow around an elliptic cylinder [7] has been investigated for an elliptic cylinder ratio 1:3. The tested fluid was air in the Reynolds number range from 8×10^3 to 7.9×10^4 . It is found that the heat transfer coefficient has its highest value at $\phi = 60-90^\circ$ over the whole Reynolds range studied.

Experiments on a cross flow heat exchangers with tubes of lenticular shape have been reported [8]. It is found that the performance of the lenticular tube heat exchanger is

superior to that of conventional circular tubes by 20% in the Reynolds number range from 2×10^4 to 5×10^4 .

Convective heat transfer with flow visualization experiments were performed in [9] to investigate the effect of yaw angle on tube in case of cross flow in the Reynolds number range from 9000 to 25000. The yaw angle of tube was changed from 0° to 28° with respect to the cross flow orientation. It is found that as the cylinder was yawed, the Nusselt number at first increases to a maximum at a yaw angle of 5° . After that it decreases to a minimum, which occurs in the range of yaw angles between 20° and 25° and then start to increase at yaw angle 28° .

In this work, the heat transfer from a tube with the presence of a plate type fin (splitter) affixed on it has been made. One of the investigated finned tube is illustrated schematically in Fig. (2-b), which shows a typical tube to which a plate splitter is attached at its back. The splitter is intended to enhance the heat transfer from the basic tube. The basic tube is a cross-flow smooth tube.

EXPERIMENTAL APPARATUS AND PROCEDURE

An experimental test rig is designed and constructed for the planned experiments is shown in Fig. (1). It consists of a low-turbulence open loop wind tunnel of square cross section (6) with dimensions 300x300 mm. The air from the laboratory room is drawn through the system, by a down stream blower (8). The flow rate is controlled by a throttle valve (10). The velocity of air stream drawn from the system is measured by the hot wire probe (2) located 750mm upstream and connected to an anemometer (14). Figure (1) shows the general layout of the experimental apparatus with the associated air supply system and heating tube (4).

Figure (2-a) shows a schematic diagram of the test tube. A polished brass tube (1) of 45 mm outside diameter, 40mm inside diameter and 250mm length is used. On the brass tube test section, there are 13 copper constantan thermocouples of 0.3mm diameter and fixed on the mid-length of the tube as shown in Fig. (2-b). The copper constantan thermocouples are fixed in thin slots (1mm deep) cut in the outer surface of the tube. Thus the average of 13 local temperatures for tube without splitter is obtained as follows:

$$T_m = (1/9). [T_1 + T_4 + T_6 + T_8 + T_9 + 0.5 \times (T_2 + T_3 + T_5 + T_7 + T_{10} + T_{11} + T_{12} + T_{13})] \quad (1)$$

One may observe that the values obtained by the thermocouples of points 2 and 13, 3 and 12, 5 and 11, and 7 and 10 should be closely equal to each other because they are located in two symmetrical positions on the test tube. Thus, the mean value of every two readings is used.

During the experimental work the difference between every two symmetrical positions was about $\pm 0.1^\circ\text{C}$. The air stream temperatures before and after the test tube were measured by a set of copper constantan thermocouple (3). The brass tube was electrically heated by means of the main heater (3) as shown in Fig. (2-a). This heater was electrically insulated by 2 cylindrical mica layers of 0.5-mm thickness (2 and 11). This heater consists of nickel chrome heating coil wound around a thermal brick rod (4) and situated in the brass tube as shown in Fig. (2-a). To reduce the heat loss from the ends of the main heater (3), two guard heaters (6) were used. The guard heater is located in electrically insulated grooves made at the brass tube ends (15).

A Teflon ring (5) located between the end of brass test tube (1) and the brass end tube (15) of outside diameter 45mm and inside diameter 40mm and its length is 5mm. The whole set is placed in between the two Teflon ends (8). For a fixed main heater input, the guard heater input is regulated so as to maintain as small a temperature difference as possible of the order less than 0.2°C across the Teflon ring (5), thereby ensuring that the heat flow from the test tube end is negligible. Six copper constantan thermocouples [13 and 14] are used for this purpose. Three thermocouples are fixed on each side of the Teflon ring (5). The thermocouples are located at the mid height of the Teflon ring at three locations each of them has 120° apart from the others. These thermocouples are connected to a digital temperature recorder (15) with an accuracy of 0.1°C as shown in Fig. 1. The total length of the test section is about 550mm.

As shown in Fig. (1) The heat input to each of the main and guard heaters is supplied to the system through an electric current stabilizer (20) and controlled by using three auto-transformer (16, 19) as well as three voltmeters (17) and three ammeters (18).

The experiments were carried out with a plain circular tube with and without splitter plate. The splitter plate has a width of 250mm, thickness of 1.6mm, and different lengths. The splitter plate lengths are $b = 0.5d_0$, $0.75d_0$, d_0 , $1.25d_0$, and $1.5d_0$. It is welded in a longitudinal slot cut in the base cylinder at $\Phi = 180^\circ$ as shown in Fig. (2-d). This means that for the cylinder of 45mm diameter, the splitter plate lengths are $b = 22.5\text{mm}$, 33.75mm , 56.25mm , and 67.5mm . The average of 16 local temperatures for the tube with a splitter plate of $b = 0.5d_0$ and $b = 0.75d_0$ is obtained as follows:

$$T_m = (1/12) \cdot [T_1 + T_4 + T_6 + T_8 + T_9 + 0.5x(T_2 + T_3 + T_5 + T_7 + T_{10} + T_{11} + T_{12} + T_{13}) + T_{14} + T_{15} + T_{16}] \quad (2)$$

Also, the average of 18 local temperatures for the tube with splitter plates of lengths of $b = d_0$, $b = 1.25d_0$, and $b = 1.5d_0$ is obtained from the following equation:

$$T_m = (1/14) \cdot [T_1 + T_4 + T_6 + T_8 + T_9 + 0.5x(T_2 + T_3 + T_5 + T_7 + T_{10} + T_{11} + T_{12} + T_{13}) + T_{14} + T_{15} + T_{16} + T_{17} + T_{18}] \quad (3)$$

The test tube assembly is supported in the wind tunnel as shown in Fig. (1), in which it can be moved to have different yaw angles adjustment by rotating the whole test tube around one of the two ends at 0° , 5.5° , 13.5° , 21° , and 30° (see Fig. (2-c)).

In order to find the heat lost by radiation from the tube, an average value of the emissivity of 0.03 for the polished brass tube is taken according to [12], in which they reported that no significant dependence of emissivity on temperature was observed. The value of heat loss by radiation was of the order of 0.5% of the input power to the main heater. Also the heat loss by conduction from the ends of the test tube may be neglected. A steady state was usually achieved after about two hours.

The local convective heat transfer coefficient and local Nusselt number are determined from the expressions:

$$h_{\phi} = Q / [A \cdot (T_{\phi} - T_{\infty})] \quad (4)$$

and

$$Nu_{\phi} = h_{\phi} d_0 / k \quad (5)$$

Also, the local convective heat transfer coefficient and the local Nusselt number on the splitter plate are determined from the expressions:

$$h_x = Q/[A.(T_x - T_\infty)] \quad (4a)$$

$$Nu_x = h_x .x/k \quad (5a)$$

Where h_x the local convective heat transfer coefficient, T_x the local surface temperature of the splitter plate, and A is the total surface area of the tube and the splitter plate.

$$A = \pi d_o L + 2 b.L \quad (6)$$

For the test tube $d_o = 0.045$ m, $L=0.25$ m, and $b = 0$ for tube without splitter plate.

The average convective heat transfer coefficient and the average Nusselt number are determined from the relations

$$h = Q/[A.(T_m - T_\infty)] \quad (7)$$

and

$$Nu = h d_o/k \quad (8)$$

The probable error in finding the average heat transfer coefficient was estimated to be about $\pm 5\%$. The projected area of the test tube A_p on the vertical plane perpendicular to the tunnel axis is:

$$A_p = d_o L \cos\theta \quad (9)$$

It is found that the maximum blockage of the wind tunnel at higher values of θ is about 13%.

For the Reynolds numbers, account was taken of the fact that the presence of the cylinder results in the 13% reduction of the cross section of wind tunnel. The blockage correction for the free stream velocity was based on Morgan [10]. For the present experiments,

$$v^* = 1.052 v \quad (10)$$

Then, the free stream Reynolds number is:

$$Re^* = v^* .d_o / \nu \quad (11)$$

The Reynolds number based on the free stream velocity normal to the yawed tube is sometimes used as an alternative to the free stream Reynolds number, i.e.,

$$Re = v^* (\cos \theta) d_o / \nu = Re^* \cos \theta \quad (12)$$

RESULTS AND DISCUSSION

For determination of the heat transfer coefficients and their correlation with air flow, some quantities were measured for each data run after steady state conditions prevailed. The power supply input to the main heater, the heat lost by radiation, the tube surface temperature, the airflow stream velocity and the free stream temperature are recorded. Because of the very small temperature difference on the sides of Teflon rings, the heat lost due to the unbalance between the main and guard heaters is neglected.

The physical properties appearing in equations (5), (8), (11), and (12) are evaluated at the reference temperature $0.5(T_m + T_w)$.

The parameters varied independently during the course of this work include the Reynolds number, the angle of yaw, and the splitter plate length. The Reynolds number is varied from 9500 to 54700, the angle of yaw is changed from 0° to 30° and the main stream velocity covered the range from 3.69 to 18.45m/s.

The data of local heat transfer coefficient for the cross tube without splitter plate is shown in Fig. 3. It is seen that the local heat transfer coefficient gradually diminishes, starting at $\Phi = 0^\circ$ with the value calculated from the stagnation point, i.e. $Nu/\sqrt{Re} = 0.722$ [15]. Increasing the distance from the stagnation point, the heat transfer coefficient decreases to its minimum approximately at some degrees before $\Phi=90^\circ$. This may be due to the flow separation which occur at about $\Phi=80^\circ$ [15]. Downstream of the separation point, the heat transfer coefficient continuously increases up to a value which becomes about the value of $Nu_m/\sqrt{Re} = 0.7$ at $Re=44200$. The improve of heat transfer at the rear of the tube is due to the back pressure that increase heat exchange of fluid in the separated re flow region. It is also noticed that with the increase of Reynolds number, the local heat transfer increases.

The average Nusselt number versus Reynolds number for a cross circular tube at different yaw angle is shown in Fig. (4). The angle of yaw changes from 0° to 21° . It is also, appearing in the figure the correlation of Zhukaukas in Ref. [11 and 12], which is described by the following equation:

$$Nu = 0.25 Re^{0.6} Pr^{0.38} (Pr/Pr_w)^{0.25} \quad (13)$$

It is also seen that, Nusselt number increase with increasing Reynolds number. In case of yaw angle = 0° the experimental results agree with $\pm 5\%$ with the results obtained from correlation (13). One may observe that, with increasing the yaw angle from 0° to 21° , the experimental data are not function of the yaw angle, but a little increase (about 10%) in Nusselt number has been noticed for, yaw angle = 21° . Figure 5 shows the comparison between Nusselt number for the present results for a cross circular tube normal to the airflow with the available data in Refs. [10, 12,13, and 14].

Figures (6-a to 6-d), show the average Nusselt number versus Reynolds number for the cross tube with back splitter plates at different yaw angles. For yaw angle= 0° , the effect of splitter plate length is small compared with Ref. [12]. Figure (6-a) shows that by increasing the yaw angle from 0° to 30° , the heat transfer increases at splitter plate length equals $0.5d_o$. It is noticed that the heat transfer coefficient that reported in the range of Reynolds number 9500 to 25000 are higher for tube with yaw angle 30° . Meanwhile, for Reynolds numbers 25000 to 54700 the heat transfer coefficient of tube with yaw angle 21° is more than the other tubes. Increasing splitter plate length from $b=0.5d_o$ to $0.75d_o$, the heat transfer coefficient increases for all angles of yaw. The highest value of heat transfer coefficient as shown in Fig. (6-b) for the tube with yaw angle 30° has been exists. Also, it is noticed that with the increase of Reynolds number, the heat transfer coefficient for all cases increases. Figures (6-c), (6-d) and (6-e) shows the relation between the average Nusselt number versus Reynolds number for tubes with splitter plate of $b = d_o$, $b=1.25d_o$, and $b=1.5d_o$ respectively. In all cases the results take the same trend as in case $b=0.5d_o$ and $b=0.75d_o$, but the enhancement of heat transfer is less than in the case of $b=0.75d_o$. In general, the average Nusselt number for the tube with back splitter plate is higher than its value for the plain tube.

The effect of splitter plate with length changing from $b=0.5d_o$ to $b=1.5d_o$ in the range of $9500 \leq Re \leq 54700$, in general, the heat transfer increases as compared with the plain tube. Also, with increasing of yaw angle from 0° to 30° the heat transfer coefficient increases more than in the case of normal tube with splitter plate. The maximum enhancement of heat transfer in this case of $b=0.75d_o$ ($b=33.75\text{mm}$) and yaw angle $=30^\circ$.

Figures (7) and (8) show the variation of local Nusselt number around the tube with different splitter tube in the range of $9500 \leq Re \leq 54700$ and yaw angle $=21^\circ$. The figures, also, show the local Nusselt number variation on the splitter plate length in dimensionless form. It is seen that with the increase of Φ around the tube, the local Nusselt number decreases to its minimum values at $\Phi = 110^\circ$. Then, the heat transfer gradually increases to $=180^\circ$. Also, the local Nusselt number increases steadily from the base of the fin towards the tip. The value of tip Nusselt number is always approximately equals the local Nusselt number at the forward stagnation point but higher than the local Nusselt number at the base of the splitter plate. It is shown that the maximum heat transfer coefficient for tube with back splitter plate of $b=0.75d_o$ and angle of yaw $\theta=30^\circ$ more than the other cases. The variation of average Nusselt number versus dimensionless splitter plate length b/d_o at $Re=30000$ for yaw angle $\theta=21^\circ$ and 30° is shown in Fig. (9).

CORRELATION

Finally, an attempt is made to correlate the results obtained in the present study. Such a correlation is quite useful for heat exchanger designer. The average Nusselt number is correlated with the other governing parameters of the test tube, i.e. yaw angle θ , back splitter plate length b , Reynolds number (Re), and Prandtl number (Pr). Following the same pattern of equation (13), a correlation is obtained:

$$Nu = [0.25 + a(b/d_o)^n] Re^{0.6} Pr^{0.38} (Pr_f/Pr_w)^{0.25} \quad (14)$$

Where $9500 \leq Re \leq 54700$, and a and n are constants varied with the yaw angle θ . The values of both a and n are presented in table (1).

Table (1) Values of the constants a and n at different yaw angles

θ°	0°	5.5°	13.5°	21°	30°
a	0.033	0.062	.074	0.122	0.1
n	0.0265	0.072	0.066	0.12	0.112

The correlation shows that the average Nusselt number is significant function of angle of yaw θ and the effect of splitter plate is relatively higher.

CONCLUSIONS

The experiments described here in the represent study are concerned with forced convection heat transfer from a cross-yawed tube with back splitter plate. The course of the experimental work covers a Reynolds number ranging from 9500 to 54700, a splitter plate length varying from $b = 0$ to $b = 1.5 d_o$ and a yaw angle changing from 0° to 30° . The results of the present work may be summarized as follows:

The effect of back splitter plate with length changes from $b = 0$ to $b = 1.5 d_o$ in the range of $9500 \leq Re \leq 54700$, in general, increases the convective heat transfer from the tube

to air flow as compared with the plain tube. Also, with increasing the yaw angle from $\theta = 0^\circ$ to 30° , the heat transfer increases more than in case of the normal tube with back splitter plate. The maximum enhancement of heat transfer in this study is for a tube of $b = 0.75d_0$ and yaw angle $\theta = 50^\circ$. With the increase of the Reynolds number Re , the average Nusselt number increases, and the local Nusselt number, increases steadily from the base of the splitter plate towards the tip. The value of tip Nusselt number is always higher than at the forward stagnation point. Also, the local Nusselt number, for the downstream half of the plain tube and for the tube with splitter plate are lower than the upstream part.

REFERENCES

1. S.C.R. Dennis, J. D. Hudson and N. Smith, Steady laminar forced convection from a circular cylinder at low Reynolds numbers, *Physics Fluids* 11, 933-940, 1967.
2. S. Nakai and T. Okazaki, Heat transfer from a horizontal circular wire at small Reynolds and Grashof numbers-I, *Int. J. Heat Mass Transfer* 18, 387-396, 1975.
3. T. H. Kuehn and R.J. Goldstein, Numerical solution to the Navier-Stokes equations for laminar natural convection about a horizontal isothermal circular cylinder. *Int. J. Heat Mass Transfer* 23, 971-979, 1980.
4. B. Farouk and S. I. Guceri, Natural convection from a horizontal cylinder-laminar regime. *Int. J. Heat Mass Transfer* 103, 522-527, 1981.
5. S. Nakai and T. Okazaki, Heat transfer from a horizontal circular wire at small Reynolds and Grashof numbers- II, *Int. J. Heat Mass Transfer* 18, 397-413, 1975.
6. A. Elmar, Total and local heat transfer from smooth circular cylinder in cross flow at high Reynolds number. *Int. J. Heat Mass Transfer* 18, pp.1771-1779, 1984.
7. O. Terukazu, N. Hideya, and T. Yukiyasu, Heat transfer and flow around an elliptic cylinder. *Int. J. Heat Mass Transfer* 27, No.10, pp.1771-1779, 1984.
8. E. K. Ruth, Experiments on a cross flow heat exchanger with tubes of lenticular shape. *ASME Trans., J. H. Transfer*, pp.571-575, 1983.
9. M. A. Shalaby and F. F. Araid, Forced convection heat transfer from a cross circular yawed tube, *Mansoura Engineering Journal (MEJ)*, vol.15, No.1, M10-M22, June 1990.
10. V. T. Morgan, The overall convective heat transfer from smooth circular cylinders, *Adv. Heat Trans.*, Vol.11, pp.199-264, 1975.
11. J. P. Holman, *Heat transfer*, McGRAW-HILL, KOGAKUSHA LTD., pp. 216-228, 1976.
12. V. Isachenko, V. Osipova, and A. Sukomel, *Heat transfer*, Mir Publishers, Moscow, 1969.
13. J. W. Hodgson, R.T. Saterback, and J. E. Sunderland, An experimental investigation of heat transfer from a spray cooled isothermal cylinder, *ASME Trans., J. H. Transfer*, vol.90, pp.457-463, 1968.
14. A. M. Ibrahim, Flow and heat transfer in a bank of tubes with integral wake splitters, Ph. D. Thesis, Madras, 1987.
15. E. Achenbach, Total and local heat transfer from a smooth circular cylinder in cross-flow at high Reynolds number. *Int. J. Heat Mass Transfer*, vol.18, pp.1387-1396, 1975.

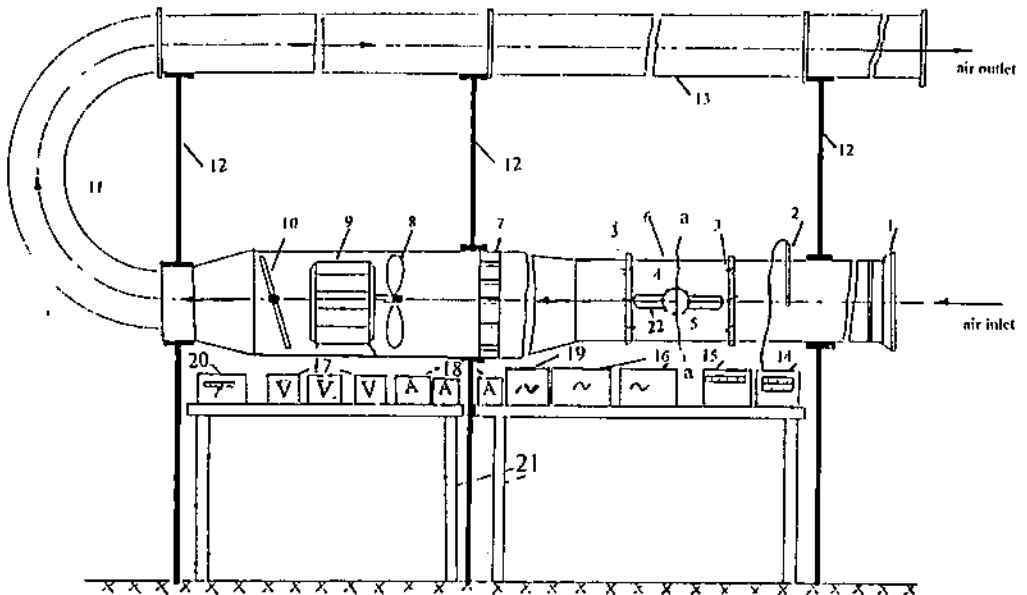

Fig. (1) Experimental Test Rig

- 1- inlet collector, 2- hot-wire probe, 3- inlet and outlet air flow temperature thermocouples, 4- test tube, 5- tube surface temperature copper-constantan thermocouples, 6- Plexiglas test section, 7- honeycomb, 8- down stream blower, 9- electric motor, 10- air throttle valve, 11- circular outlet connection, 12- air duct carriers, 13- air outlet pipe, 14- anemometer, 15- temperature recorder, 16- auto transformer of guard heaters, 17- ammeter, 18- voltmeter, 19- auto-transformer of main heater, 20- electric current stabilizer, 21- movable tables, 22- slit cover.

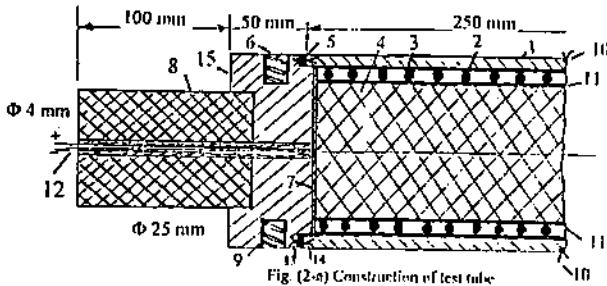

Fig. (2-a) Construction of test tube

- 1 brass tube, 2- outer tube of mica, 3- electric heater, 4- thermal brick test, 5- Teflon rings, 6- guard heaters, 7- thermal insulation, 8- Teflon tube connection, 9- electric insulator of mica, 10- surface tube copper constantan thermocouples, 11- inner tube of mica, 12- electric cable, 13 and 14- copper constantan thermocouples of guard heaters, 15- brass end section.

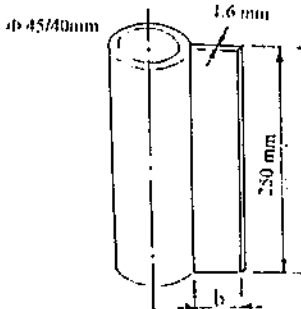

Fig. (2-d) Dimensions of brass tube with splitters

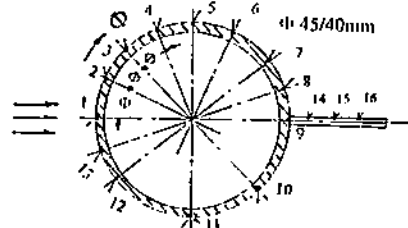

Fig. (2-b) Thermocouple distribution on the midlength of the brass tube test section.

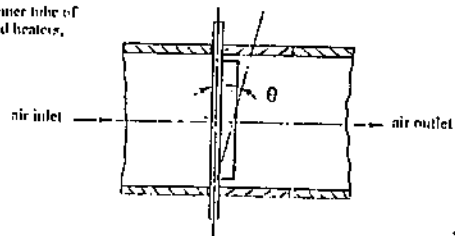

Fig. (2-c) Plan of the test section duct (see a-a in Fig. 1)

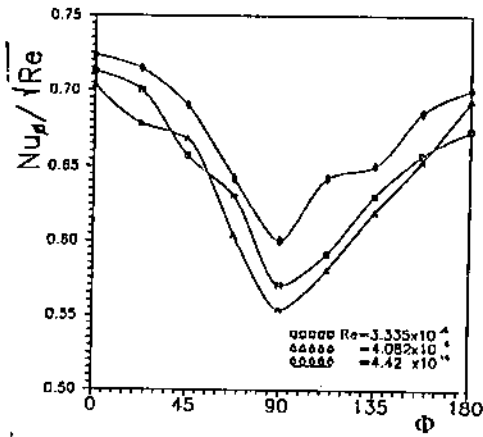

Fig. (3) Heat transfer variation around a circular tube at different Reynolds number

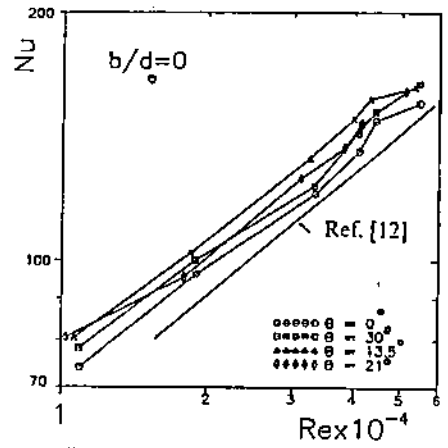

Fig. (4) Average Nusselt number versus Reynolds number for a cross circular tube

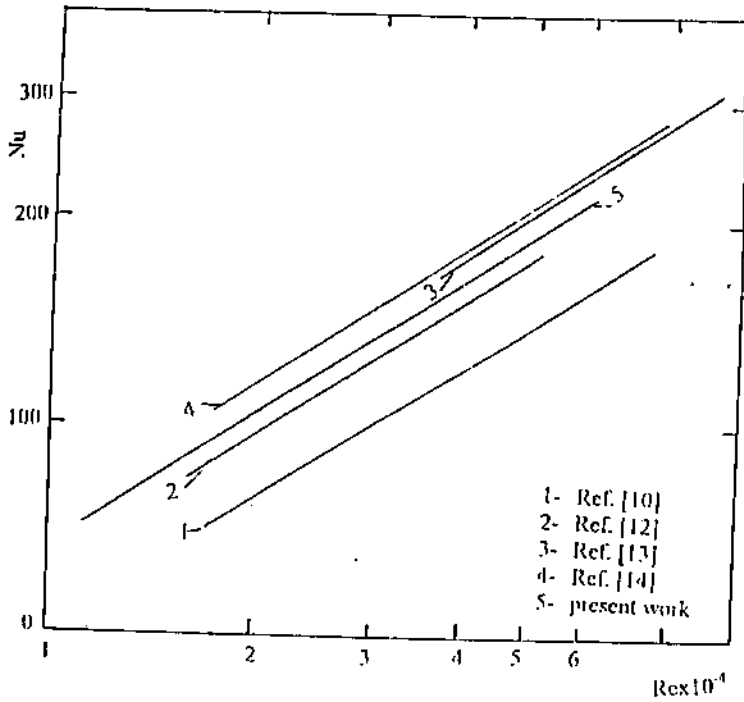

Fig. (5) Comparison between the present results for cross circular tube with data in Ref. [10, 12, 13, and 14]

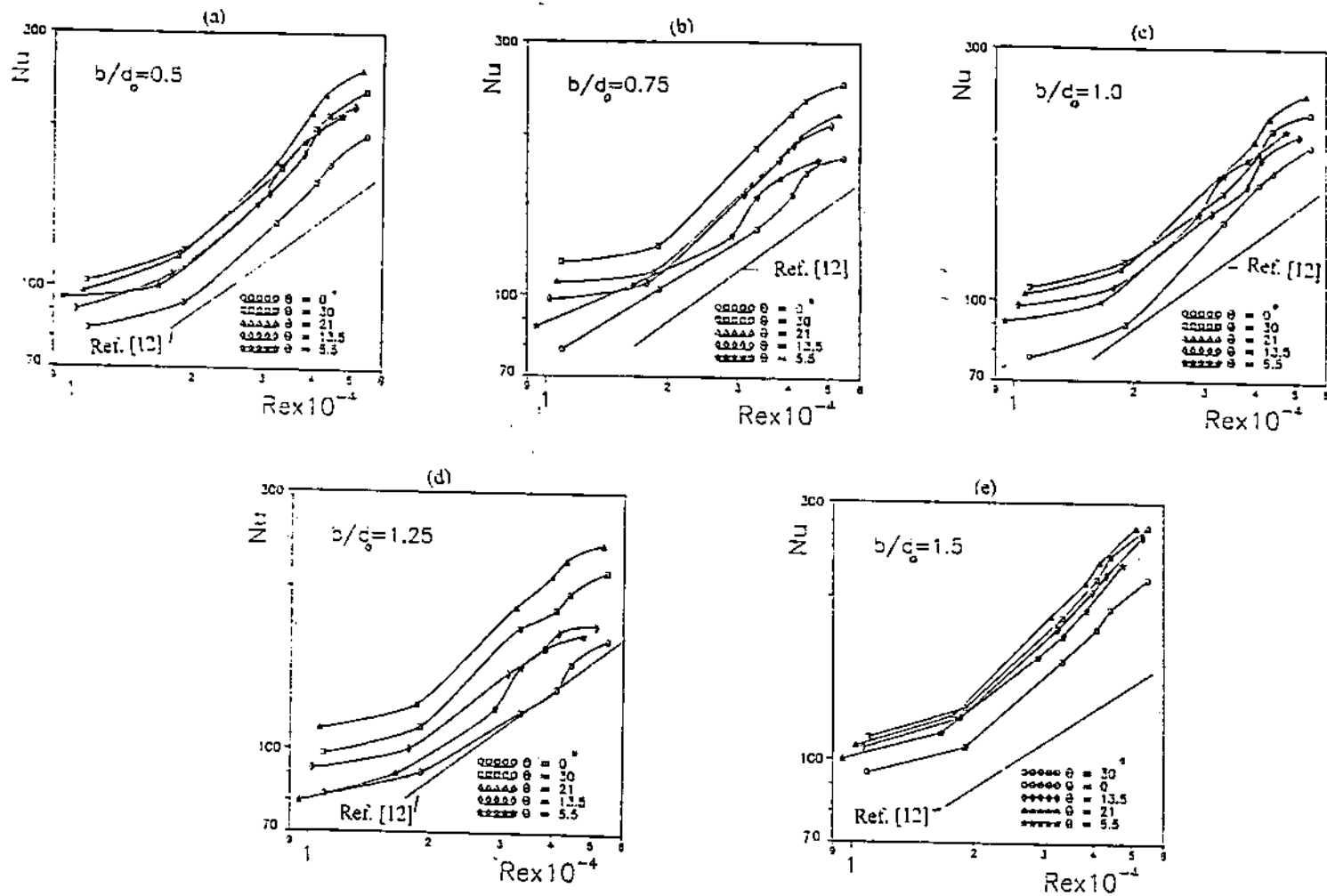

Fig. (6) Average Nusselt number versus Reynolds number for a cross circular tube with back splitter plate with different lengths and different yaw angles

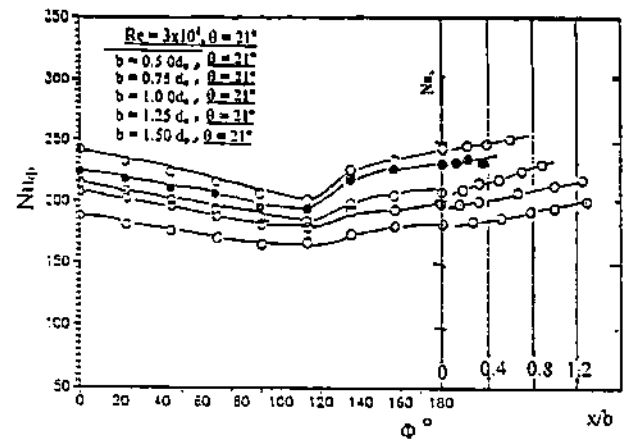

Fig. (8) Comparison of local Nusselt number for yawed cross flow tube with different splitter plate at $Re=30000$

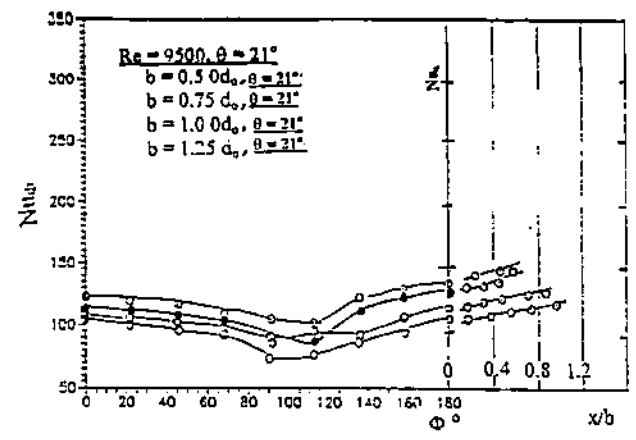

Fig. (7) Comparison of local Nusselt number for yawed cross flow tube with different splitter plate at $Re=9500$

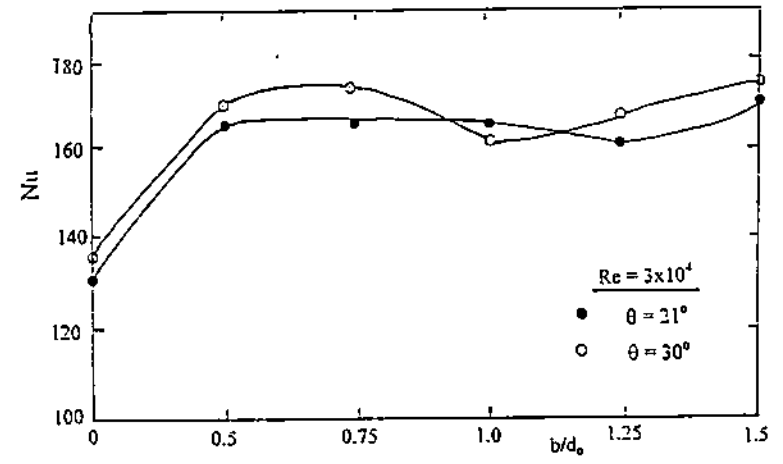

Fig. (9) Average Nusselt number versus back splitter plate length at yaw angle = 21° and 30°