

12-9-2020

Proposed Scheme for Characterization of Power Quality Disturbances.

Akram Ibrahim El-Mitwally

Elect. Eng. Dept., Mansoura University, Mansoura, 35516. Egypt

A. Abdelmageid

Elect. Eng. Dept., Mansoura University, Mansoura, 35516. Egypt

S. Fathy

Elect. Eng. Dept., Mansoura University, Mansoura, 35516. Egypt

Follow this and additional works at: <https://mej.researchcommons.org/home>

Recommended Citation

El-Mitwally, Akram Ibrahim; Abdelmageid, A.; and Fathy, S. (2020) "Proposed Scheme for Characterization of Power Quality Disturbances.," *Mansoura Engineering Journal*: Vol. 32 : Iss. 3 , Article 4.

Available at: <https://doi.org/10.21608/bfemu.2020.128695>

This Original Study is brought to you for free and open access by Mansoura Engineering Journal. It has been accepted for inclusion in Mansoura Engineering Journal by an authorized editor of Mansoura Engineering Journal. For more information, please contact mej@mans.edu.eg.

Proposed Scheme for Characterization of Power Quality Disturbances

طريقة مقترحة للتوصيف الكمي لاضطرابات جودة التغذية الكهربائية

A. Elmitwally, A. Abdelmageid, and S. Fathy
Elect. Eng. Dept., Mansoura University,
Mansoura, 35516, Egypt

ملخص

يقترح البحث منظومتين تعتمدان على نظرية الموجات والشبكات العصبية الاصطناعية للتوصيف الشامل لاضطرابات جودة التغذية الكهربائية المسجلة في دراسات المسح و ذلك بتعيين مقدار الحيود وكذلك فترة حدوثه إضافة إلى نوعه حتى يمكن إعداد تقارير وافية عن نتائج دراسات المسح للبيئة الكهرومغناطيسية أياً، حيث تستخرج الصفات المميزة للاضطراب باستخدام طريقة تحليل الموجات و يتم تقدير حاصل ضرب المقدار و الفترة باستخدام شبكات عصبية ذات تصميم وتدريب مناسبين، كما يتم مقارنة أداء الطريقتين وكذلك التصميمات المتنوعة للشبكة العصبية المقدرة للوصول إلى أفضل أسلوب للتقدير الكمي لكل نوع من الاضطرابات بشكل منفرد وكذلك أنسب منهج للتقدير بشكل عام.

Abstract

A voluminous amount of disturbance waveforms are captured and recorded by power quality survey projects. These disturbances need to be automatically classified and characterized to provide informative and useful results about the power quality condition of the system. Intensive research is conducted to accomplish efficient automatic classification tools. There is still a notable scarcity in apt techniques for characterization or quantification of disturbances. In this paper, a scheme based on discrete wavelet transform and neural networks is proposed to characterize the recorded power quality disturbances. A routine is presented to compute the disturbance duration. A dedicated neural network is used to estimate the duration-magnitude product of the disturbance. The design and structure of the neural estimator is addressed. An alternative scheme for designing the estimator is also proposed and described. The performance of the two methods is tested with many disturbances of 6 different types. The results are compared to select the best estimators relevant to each disturbance type.

1. Introduction

The proliferation of power electronic devices and nonlinear loads in electric power networks has triggered a growing concern for power quality issues from both utilities and power users. The opening of power markets, deregulation and restructuring of the electric power industry is further accentuating the interest in the quality of the electric supply[1]. Power quality (PQ) phenomena are investigated directly from actual recorded disturbance waveforms thanks to widely available power monitor equipment. Furthermore, Manufacturers are integrating power quality monitoring functions in their products such as power meters, digital relays and event recorders. These disturbance recordings are stored as three-phase

voltage and current time-series which bring a wealth of information about each power quality event. They are useful to conceptualize the process of power quality disturbances and to find their causes[2]. The existing methods to analyze and identify power disturbances are primarily based on visual inspection of the disturbance waveforms. The power-quality engineer's knowledge plays a critical role, and many times, the power-quality engineer is swamped with an enormous amount of data to inspect. Manual sifting of recorded PQ disturbances is very tedious and time consuming. Thus, it is desirable to develop automatic methods for detecting, identifying, and analyzing various disturbances [3]. Advanced tools for the computerized analysis

and classification of power-quality disturbance are currently available [4]. However, since the correct classification rate for the actual events is not as high as classification methods used in areas such as pattern recognition, speech recognition, and so on, there is still room for improvement [3]. Power quality study have several aspects including [1-3]: 1) Sensitive detection of power disturbances, 2) Identification of the types and causes of power disturbances, 3) Quantification of the extent of power disturbances (or waveform distortions) and their negative impacts on power systems, 4) Real time measurement of the parameters of signal components in power disturbances, and 5) Locating the sources of power disturbances in electric power networks. The first two objectives are verified using many recently reported techniques [2-6]. The third aspect above can be fulfilled using PQ indices, which are the concise numerical representations characterizing the nature of a PQ event based on the time and/or frequency information of the disturbance waveform. PQ indices also serve as the basis for comparing the negative impacts of PQ events on power systems/customers in a quantitative manner. On the other hand, it is essentially requested to estimate the magnitude and duration of the PQ disturbances for their ranking, severity assessment and for giving more insight into the electromagnetic environment of the survey site as indicated in aspect no. 4. There is still a notable lack in technical information and reported research exploring this task. However, in [7, 8], characterizing the signal is done by monitoring the standard deviation of discrete wavelet transform (DWT) coefficients at different resolution levels. The method is applied specifically to estimate the magnitude of voltage sag disturbances. In [9], a DWT-based method is presented to determine the duration of transitory PQ disturbances such as impulse and oscillatory transients. We have not found yet a reported approach that is generally able to estimate, even approximately, both the duration

and magnitude of recognized momentary PQ disturbances.

In a preceding paper [10], the authors presented an algorithm for classifying the recorded PQ disturbance signals acquired through the PQ monitoring stage. It is based on performing DWT multi-resolution analysis of the signal and using the standard deviation pattern of the DWT coefficients at the different levels as the source of extracting the feature vector. By using a dedicated neuro-fuzzy classifier, the recorded disturbances are classified into different disturbance types. Nevertheless, no information about ranking the disturbance cases within each category or expressing their relative severity is provided. This hinders the production of a more helpful PQ survey report providing information about the types of existing PQ problems as well as their determinant characteristics, e.g., magnitude and duration. The targeted PQ survey report will portray the PQ status of the monitored system more clearly.

In this paper, a scheme is proposed to extend the algorithm given in [10] to provide the magnitude and duration of the PQ disturbance in addition to its type. The scheme is based on the artificial neural networks (ANNs). An ANN is constructed to estimate the disturbance magnitude for each type. The time duration of the disturbance is computed from the recorded time samples of the signal. Moreover, an alternative approach is also proposed to estimate the disturbance magnitude. It is based on the difference between the standard deviation pattern of the DWT coefficients of the disturbance signal and the pure sinusoid template. The two methods are described and their characterization capabilities are compared.

II. The Proposed Scheme

The recorded power quality event signals obtained from the PQ survey phase are assumed to have a time span of 18 fundamental cycles each. Also, the first cycle in the captured signal is assumed to be distortion-free. The proposed generalized power quality problems

characterization algorithm is described as given below.

A. Duration time estimation

The duration time D of the disturbance can be defined as the time interval for which the signal is deviated from its normal steady state conditions. As the voltage waveform is typically sinusoidal with fixed amplitude and frequency, any violation to this template is considered a PQ disturbance. This event is captured by PQ monitoring instruments. The recorded event signals have usually a fixed time span. D is typically included within this time span as a fraction of it. The parameter D is estimated from the recorded time-domain signal as follows:

1. Fast Fourier transform (FFT) is used to obtain the fundamental frequency component of the stored event signal [2]. Then, the signal is normalized by dividing each sample value by the peak fundamental value.
2. To focus only on the features of the disturbance, fundamental frequency component is subtracted from the normalized signal to give the normalized mere disturbance signal (NMDS) [10, 11]. Ideally, NMDS will have zeros out the disturbance region in overall time span. It is required to explore the start and end positions of that zero values of the NMDS.
3. To have only positive values for the later signal, the values of its samples are squared. As a result, the very small sample values becomes infinitely smaller and the large sample values are more enlarged. This facilitates specifying the start and end points of the disturbance.
4. Starting from the time sample number one and going ascendingly, each sample value is compared against a certain threshold level taken as a fixed ratio of the maximum value of the NMDS. The

first sample whose value will exceed the threshold is marked as the disturbance start point T_s . Then comparison is stopped.

5. Starting from the last time sample (number N) and going descendingly, each sample value is compared against the threshold level. The first sample whose value will exceed the threshold is marked as the disturbance end point T_e , and comparison is stopped.

6. The disturbance duration D is determined as:

$$D = T_e - T_s \quad (1)$$

7. As a by-product, mean square value (power) of the NMDS P_{NMDS} is calculated to express how much the magnitude is deviated from the normal conditions. This value will be used in the magnitude estimation algorithm.

The above technique is depicted by the diagram given in Fig.1.

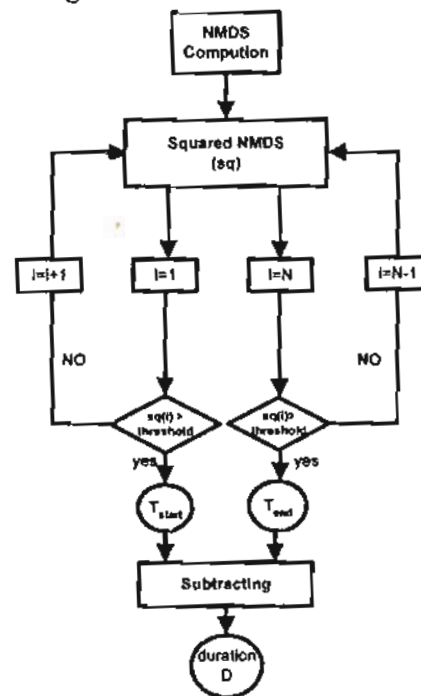

Fig.1 Schematic of duration computation algorithm

Table 1 shows the results of computing D using this method when applied to 6 different

disturbance examples depicted in Fig.2 It is evident that the estimated D is very close to its true value with high accuracy. This ensures the validity of the given method in estimating the disturbance duration.

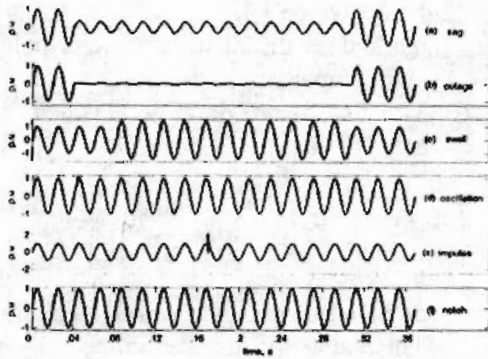

Fig.2 Disturbance signals examples

Table1 Duration calculation for example disturbances

Fig.2	T_s (s)	T_e (s)	D (s)	true D
(a)	0.040	0.304	0.2639	0.27
(b)	0.040	0.308	0.2679	0.27
(c)	0.081	0.304	0.2230	0.22
(d)	0.043	0.046	0.0028	0.0026
(e)	0.166	0.170	0.0043	0.0043
(f)	0.1512	0.1518	0.0006	0.0006

B. Magnitude estimation

1. Method 1

1. The Debauchee mother wavelet "db4" is adopted to perform the multi-resolution analysis MRA of the NMDS up to the 12th level at a sampling rate of 256 sample points per fundamental cycle [12, 13]. Then, the standard deviation of the DWT coefficients of each level is computed yielding 12 parameters for each signal [7, 8].
2. A feature vector of 13 elements length, the later 12 standard deviations beside the power P_{NMDS} , is assembled as the gross candidate feature vector.
3. According to the disturbance type decided by the classification algorithm, a dedicated artificial neural network (ANN) is triggered to estimate the

duration-magnitude product (DM) of the disturbance signal.

4. Since the duration D is determined as in the section A above, the disturbance magnitude M can be computed.

Method 1 is revealed schematically in Fig.3. Fig.4 from top to bottom shows an example of applying this algorithm to a sag signal.

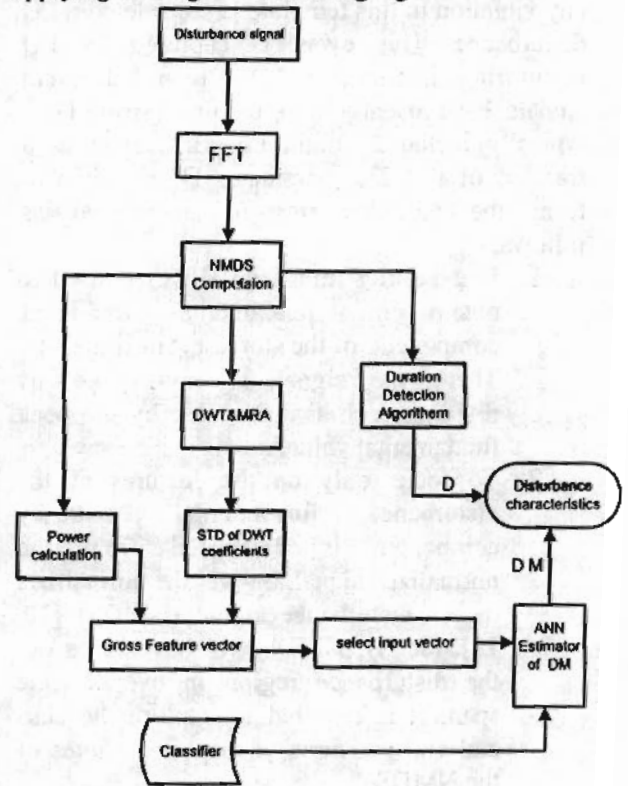

Fig.3 Schematic of the proposed algorithm with method 1.

2. The alternative Method (Method 2)

1. The Debauchee mother wavelet "db4" is adopted to perform the MRA of the normalized event signal up to the 12th level and at a sampling rate of 256 sample points per fundamental cycle. Then, the standard deviation of the DWT coefficients of each level is computed yielding 12 parameters for each signal.

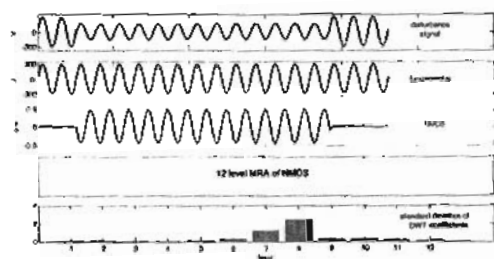

Fig.4 Example of applying method 1 to a sag signal

2. The Debauchee mother wavelet "db4" is adopted to perform the MRA of the normalized fundamental waveform computed in step 1 of section II.B.1 up to the 12th level and at a sampling rate of 256 sample points per fundamental cycle. Then, the standard deviation of the DWT coefficients of each level is computed yielding 12 parameters for the fundamental signal.
3. The standard deviations of DWT coefficients of normalized event signals obtained in step 1 above are subtracted from their counterparts of the fundamental signal obtained in step 2.
4. A feature vector of 13 elements length, the later 12 standard deviations differences obtained in step 3 beside the power P_{NMDS} , is selected as the candidate gross feature vector.
5. According to the disturbance type decided by the classification algorithm, a dedicated artificial neural network (ANN) is triggered to estimate the duration-magnitude product (DM) of the disturbance signal.
6. Since the duration D is determined as in section II.A above, the disturbance magnitude M can be computed.

Method 2 is revealed schematically in Fig.5. Fig.6 from top to bottom shows the steps of applying this algorithm to a sag signal.

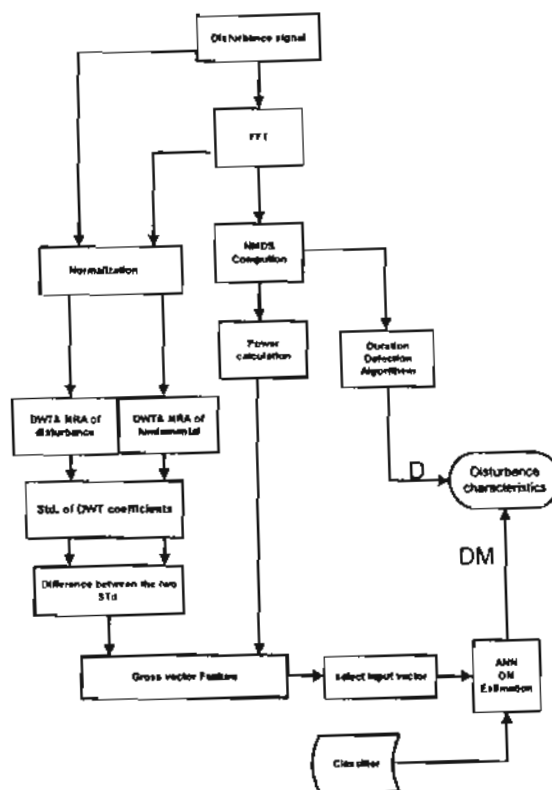

Fig.5 Schematic of the proposed algorithm with method 2

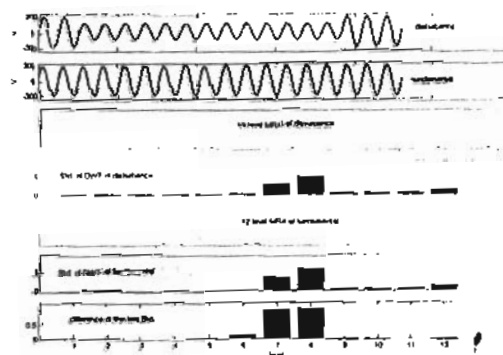

Fig. 6 Example of applying method 2 to a sag signal.

III. Developing the Neural DM estimator

A. Training and testing data

A large number of disturbance signal examples are needed to construct and test the ANN DM estimator. 25 examples of each disturbance class are generated by simulating the model power system of Fig.7 using ATP/EMTP software.

This power system consists of 13 buses and is representative of a medium-sized industrial plant fed by a utility supply at 69 kV. It also has a local generator (G1) operating at 13.8kV, transformers, lines, capacitors and loads [14].

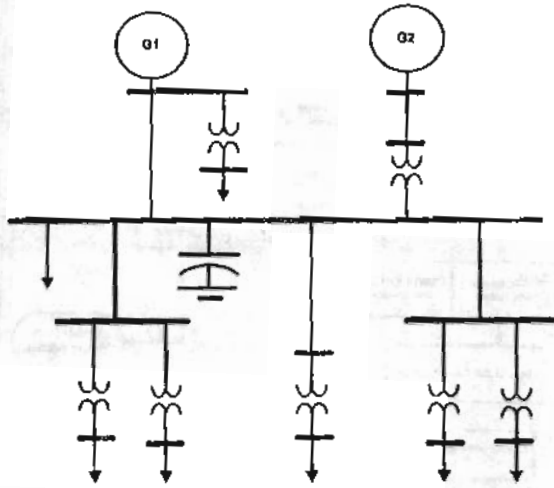

Fig.7 Model power system

There are 6 transient disturbances concerned in this study as section III.B blow. The start instant, duration, and magnitude of electromagnetic disturbances in power system are random and range widely. Any targeted ANN estimator should have been trained with adequate amount of the possible versions of the disturbance waveforms to be able to give its DM product correctly [11-13]. 25 example waveforms of each disturbance that cover its expected range of variation are generated assuming different operating conditions and parameter values.

B. Structure and Training

Six disturbance types are considered in this paper which are sag, swell, outage, notch, impulse and oscillatory transients. For the first three types, the term magnitude (M) is defined as the absolute difference between the peak values of the signal before and during the existence of the event. Whereas, for the latter three types, M is defined as the difference

between the maximum value of the signal during the event and its corresponding normal value. ANN DM estimator is to be designed and dedicated for each disturbance class. The input vector to the ANN DM estimator is selected from the 13-element gross feature vector described in section II.B. Three candidate groups of input vector are compared as inputs to the ANN DM estimator. The first is a 3-element input vector composed by summing up each 4 subsequent values of the 12 standard deviations (of the DWT coefficients of the 12 resolution levels). The second is a 4-element input vector which are the previous three elements besides the power P_{NMDS} . The third is a 12-element input vector which are just the 12 standard deviations. The ANN estimator used is a three-layer feed forward ANN with only one output neuron for the DM value [15]. The number of the hidden layer neurons are provided in Tables 2 and 3, for method 1 and method 2 respectively. The transfer function of the hidden layer neurons is taken as "tansig" and that of the output neuron is linear. The adopted training algorithm is Levenberg Marquardt technique due to its reported efficacy [15]. The target training error is set as 10^{-5} and it is met in less than 600 training epochs for all cases. This was enough for the ANN DM estimator to recognize the DM of the training examples with 100% efficiency.

Table 2 Training information of method 1

No. of inputs	3	4	12
Type	No. of hidden neurons		
sag	85	150	80
swell	70	150	60
outage	65	70	82
notch	58	90	60
impulse	75	100	70
oscillation	100	60	90

C. Testing results and comparison

The proposed PQ disturbance characterization schemes are tested to estimate the duration and magnitude of various sets of previously unseen

Table 3 Training information of method 2

No. of inputs	3	4	12
Type	No. of hidden neurons		
sag	85	160	80
swell	70	150	58
outage	65	70	82
notch	56	90	60
impulse	76	95	70
oscillation	70	50	80

disturbance signals of the 6 different classes. The disturbance duration D is determined via the duration estimation routine presented in section II.A. The algorithm given in section II.B is followed to obtain the proper input vector. Then, the ANN DM estimator is resorted to provide the product DM. For evaluation purpose, the case is considered to be correctly characterized if the error in the estimated DM is within 20% limit of its actual value. For the two schemes, the three, four and twelve-input ANN DM estimators of each disturbance class are compared as illustrated in Tables 4, 5 and 6, respectively.

Table 4 Summary of test result for 3 inputs

Type of disturbance	Method 1			Method 2		
	Correct	Incorrect	Efficiency %	Correct	Incorrect	Efficiency %
sag	8	0	100	7	1	87.5
swell	6	1	86	7	0	100
outage	9	0	100	9	0	100
notch	4	3	57	6	1	86
impulse	9	0	100	9	0	100
oscillation	5	4	55.5	6	3	66.6
Total	41	8	83.7	44	5	89.8

Table 7 summarizes the overall results of the two methods. It is noticed that method 1 with 4 input ANN DM estimator gives the best global performance for the whole test cases in the different 6 disturbance types. It yields 100% accuracy in DM estimation for 3 types of the 6 disturbance types. However, this scheme is not the best in estimating DM for swell and notch

disturbance types. The swell is best characterized by method 2 with 3 input ANN estimator. Whereas, the notch is best characterized by method 2 with 12 input ANN estimator. The best ANN DM estimators are corresponding to the highlighted cells as shown in Table 7.

Table 5 Summary of test result for 4 inputs

Type of disturbance	Method 1			Method 2		
	Correct	Incorrect	Efficiency %	Correct	Incorrect	Efficiency %
sag	8	0	100	7	1	86
swell	6	1	86	6	1	86
outage	9	0	100	9	0	100
notch	5	2	71	5	2	71
impulse	9	0	100	9	0	100
oscillation	8	1	89	6	3	66.6
Total	45	4	91.8	42	7	85.7

Table 6 Summary of test result for 12 inputs

Type of disturbance	Method 1			Method 2		
	Correct	Incorrect	Efficiency %	Correct	Incorrect	Efficiency %
sag	5	3	62.5	4	4	50
swell	5	2	71	5	2	71
outage	9	0	100	8	1	88.8
notch	5	2	71.4	7	0	100
impulse	8	1	89	9	0	100
oscillation	6	3	66.6	6	3	66.6
Total	38	11	77.6	39	10	79.6

The proposed two methods can be used to characterize adequately the 6 studied disturbance types. In general, method 1 with 4 input ANN DM estimator can be recommended as the superior technique for PQ disturbance characterization. This is because, besides its efficacy, the required 4 inputs are the same effective inputs used in the earlier stage for disturbance classification [10]. This will greatly reduce the computations needed to characterize the disturbance after its classification to a minor amount.

Table 7 Comparison of results in terms of estimation efficiency (%)

		Oscillation	Impulse	notch	outage	swell	sag	Total
Method 1	12 inputs	66.6	87.5	71.4	100	63.6	62.5	77.5
	4 inputs	89	100	71	100	86	100	91.8
	3 inputs	55.5	100	57	100	86	100	83.7
Method 2	12 inputs	66.6	100	100	88.8	63.6	50	79.6
	4 inputs	66.6	100	71	100	89	89	85.7
	3 inputs	66.6	100	86	100	100	89	89.8

Table 8 Performance of best DM estimators for test cases

sag		swell		outage		notch		impulse		Oscillations	
M1-4inputs		M2-3inputs		M1-4inputs		M2-12inputs		M1-4inputs		M1-4inputs	
A	E	A	E	A	E	A	E	A	E	A	E
14	16.673	21.8	20.3	76.5	77.5597	1.223	1.2378	4.7016	4.7589	0.4492	0.4669
28.8	25.351	49.91	51.4	76.7	78.2476	1.7531	1.8247	4.8399	4.8735	0.4758	0.449
37	35.6	57.39	56.1	76.9	78.8742	0.35938	0.3155	3.0546	3.0853	0.1969	0.1969
40.7	40.7	75.52	77.3	86.6	89.3289	0.09141	0.0968	3.4277	3.1555	0.1781	0.1849
49.4	41.957	80.933	88.2	110	109.378	0.64687	0.7018	4.425	4.4049	0.5344	0.4337
73.418	72.804	88.563	91.5	146	145.806	0.69531	0.722	-5.859	-5.986	0.5859	0.4933
73.6	72.525	89.89	89.8	176	175.072	0.525	0.5251	5.338	5.49	0.60157	0.7834
72.95	70.092	61.24	60.3	176	173.567	1.223	1.2378	3.6118	3.5852	0.74998	1.574
64.2	57.7	39.4	41.2	219.58	217.88	1.7531	1.8247	6.0938	7.7829	1.1812	1.1077

A: actual, E: estimated, M1:method 1, M2:method 2

Table 8 provides the detailed test results of the best ANN DM estimators. 9 test cases are considered for each disturbance class. The duration D is expressed in milliseconds for the given DM values. The negative DM value for the impulse refers to an impulse that occurs during the negative half cycle (downward impulse).

IV. Conclusion

Two methods for designing and developing an ANN duration-magnitude product estimator for PQ disturbances are proposed and analyzed. These methods are based on DWT multi-resolution analysis for feature vector extraction and ANN for prediction. A dedicated routine has been presented to compute the disturbance

duration using the recorded time samples. Three, four and twelve-input ANN DM estimators have been formed and compared for the two proposed schemes. The best estimator structure for each disturbance class is reached. The 4-input ANN DM estimator produced according to method 1 is the best overall DM estimator. It has the maximum prediction efficiency for most of the disturbance classes. Moreover, the used 4-inputs are the same inputs used in the preceding disturbance classification procedure. The presented technique can assist in automatically preparing more informative power quality survey report that indicates both qualitative and quantitative assessment of the recorded PQ disturbance signals.

V. References

- [1] Tao Lin and Alexander Domilar" On power Quality Indices and Real Time Measurement" IEEE Trans. On Power Delivery, Vol.20, No.4, October 2005, pp.1-11.
- [2] Surya Santoso, W. Mack Grady, Edward J. Powers, Jeff Lamoree and Siddharth C. Bhatt "Characterization of Distribution Power Quality Events With Fourier and Wavelet Transforms," IEEE Trans. On Power Delivery, Vol.15, No.1, January 2000, pp. 247-254.
- [3] T. X. Zhu, S. K. Tso and K. L. Lo, " Wavelet-Based Fuzzy Reasoning Approach to Power Quality Disturbance Recognition," IEEE Trans. On Power Delivery, Vol.19, No.4, October 2004, pp.1928-1935.
- [4] Wael R. Anis Ibrahim and Medhat M. Morcos. "Artificial Intelligence and Advanced Mathematical Tools for Power Quality Application :A Survey," IEEE Trans. On Power Delivery, Vol.17, No. 2, April 2002, pp.668-673.
- [5] M. S. Kandil, S. A. Farghal and A. Elmitwally. "Refined Power Quality Indices," IEE proc. On Generation, Transmission, and Distribution, Vol.148, No. 6, pp.590-596, Nov., 2001.
- [6] H. M.S.C.Herath,Victor J. Gosbell and Sarath Perera" Power Quality Survey Reporting: Discrete Disturbance Limits" IEEE Trans. On Power Delivery, Vol.20, No.2, April 2005.
- [7] A.M. Gaouda , M.M.A. Salama and M.R. Sultan,"Automated Recognition System for Classifying and Quantifying the Electric power Quality," IEEE PES summer meeting,1998, pp.244-248.
- [8] A.M. Gaouda, M.R. Sultan and A.Y.Chikhanni, "Power Quality Detection and Classification Using Wavelet-Multiresolution Signal Decomposition," IEEE Trans. On Power Delivery , Vol.14, No.4, October 1999, pp. 169-1476.
- [9] Angrisani L., Daponte P., Apuzzo M. and Testa A., "A Measurement Method Based on the Wavelet Transform for Power Quality Analysis," IEEE Trans. On Power Delivery, Vol. 13, No. 4, 1998, pp.990-998.
- [10] A. Abdelmageid, A. Elmitwally and S. Fathy,"A Generalized Approach for Automatic Recognition of Power Quality Disturbances," the International Journal of Distributed Energy Resources, 2007, in press.
- [11] Zwe-Lee Gaing, "Wavelet-Based Neural Network for Power Disturbance Recognition and Classification," IEEE Trans. On Power Delivery, Vol.19, No 4, October 2004, pp.1560-1568.
- [12] B.perunicic, M.Mallini, Z.Wang,Y.liu "Power Quality Disturbance Detection and Classification using Wavelet and Artificial Neural Networks," IEEE, PES summer meeting ,1998, pp.77-82.
- [13] W. Kanitpanyacharoean and S. Premrudeepreechacharn, "Power Quality Problem Classification Using Wavelet Transformation and Artificial Neural Network," IEEE , PES annual meeting. 2004.
- [14] Daniele Castaldo, Alessandro Ferrero, Simona Salicone, Alfredo Testa, "A Power-Quality Index Based on Multi-point Measurements" IEEE Bologna Power Tech conference 2003, June 23-26, Bologna, Italy.
- [15] Howard Demuth and Mark Beale, "Neural Network Toolbox User's Guide", The MathWorks, 1998.

