

3-18-2021

## Steering Vector Transformation Technique for the Design of Point Sources Wideband Beamformer.

Mohamed Mohamed Shaban

*Electronics and Communication Engineering Department., Faculty of Engineering., El-Mansoura University., Mansoura., Egypt.*

Sherief Ahmed Kishk

*Electronics and Communication Engineering Department., Faculty of Engineering., El-Mansoura University., Mansoura., Egypt.*

Hamdy El-Mikati

*Electronics and Communication Engineering Department., Faculty of Engineering., El-Mansoura University., Mansoura., Egypt.*

Follow this and additional works at: <https://mej.researchcommons.org/home>

---

### Recommended Citation

Mohamed Shaban, Mohamed; Ahmed Kishk, Sherief; and El-Mikati, Hamdy (2021) "Steering Vector Transformation Technique for the Design of Point Sources Wideband Beamformer.," *Mansoura Engineering Journal*: Vol. 34 : Iss. 3 , Article 5.

Available at: <https://doi.org/10.21608/bfemu.2021.157667>

This Original Study is brought to you for free and open access by Mansoura Engineering Journal. It has been accepted for inclusion in Mansoura Engineering Journal by an authorized editor of Mansoura Engineering Journal. For more information, please contact [mej@mans.edu.eg](mailto:mej@mans.edu.eg).

## Steering Vector Transformation Technique for the Design of Point Sources Wideband Beamformer

تحويل متجه مصفوفة الهوائيات من أجل تصميم مشكلات الأشعة في المدى الترددي العريض

M.E. Shaban, S.E. Kishk and H.A. Elmikati, *Senior Member IEEE*

Department of Electronics and Communications Engineering, Mansoura University, Mansoura, Egypt

### الملخص:

في هذا البحث يتم تحويل متجه مصفوفة الهوائيات لمشكل الأشعة التقليدي في المدى الترددي العريض لتثبيت الشعاع الرئيسي مع التردد. وقد تم عرض عدة امثلة لتوضيح مدى أفضلية مشكل الأشعة المقترح على مشكل الأشعة التقليدي. وقد لوحظ أنه كلما زاد عدد عناصر مصفوفة الهوائيات أو قلت المسافة بين العناصر يظل مشكل الأشعة المقترح له شعاع رئيسي أفضل من مشكل الأشعة التقليدي. أخيراً فقد لوحظ أن باستخدام النوافذ نستطيع الحصول على شعاع رئيسي أفضل لمشكل الأشعة المقترح عن مشكل الأشعة التقليدي.

### Abstract

Steering vector transformation technique for wideband antenna array of point sources is presented. Wideband direction of arrival (DoA) estimation using this technique is illustrated. In the present work, steering vector transformation is applied to the conventional frequency domain beamformer to enhance the frequency invariance of the mainlobe pattern. Several simulation examples are presented to illustrate the advantage of the proposed frequency domain beamformer over the conventional one. As the array size increases or the interelement spacing decreases, the proposed beamformer still has a better frequency invariant property of the mainlobe pattern than the conventional beamformer. Finally, using windows, a better frequency invariant property of the mainlobe pattern is obtained by the proposed beamformer than the conventional one.

*Index Terms:* smart antennas, steering vector, direction of arrival (DoA), wideband beamformer.

## 1. Introduction

Future generations of wireless communication systems such as the fourth generation mobile communication system and broadband wireless access networks are expected to provide a wide variety of services (e.g., multimedia, broadcasting, etc.) through reliable high data rate wireless channels. An effective way to increase the data rate in future wireless communication systems is to increase the signal bandwidth along with the use of smart antennas.

Smart antennas improve the quality of wireless transmission, which is limited by interference, local scattering

and multipath propagation. Until recently, research on smart antennas used as beamformers has been restricted mainly to narrowband wireless systems [1-3]. The beamforming techniques used in narrowband systems are inadequate for wideband systems because they are unable to track a desired user or form nulls or low sidelobes towards interfering sources over a wide frequency band. In order to overcome the shortfalls of narrowband beamformers, several wideband beamforming methods have been proposed recently [1-10]. An approach to broadband design is to develop a frequency invariant

beam pattern property for a theoretical continuous sensor and then to approximate this continuous sensor by an array of discrete sensors [4, 5]. A second approach is to use a frequency domain beamformer [6, 7]. Since narrowband beamforming is conceptually simpler than broadband beamforming, the beamformer is implemented such that the signal received at each sensor is decomposed into its frequency domain components using a fast Fourier transform and then each component is applied to a specific delay and sum beamformer. A third method is to use a rectangular array antenna consisting of identical wideband antenna elements arranged in a horizontal rectangular lattice with spacing equal to a half wavelength at the highest frequency of operation [8] or a linear array with a tapped delay line connected to each element [9, 10]. This wideband weighting scheme relies on the inverse discrete Fourier transform (IDFT) of a specified desired array response. The resulting weights are real-valued numbers, which in practice can be realized using amplifiers or attenuators.

Due to the rapid increase in the broadband services, the problem of localization of sources radiating energy by observing their signal received at spatially separated sensors is of considerable importance [1, 2]. An efficient method for DoA estimation of narrowband signals is the matrix pencil method [11]. For wideband signals, a steering vector transformation technique [12] is applied to the received signal in order to transform the steering vector at any frequency within the design band into that at a specified reference frequency before applying the matrix pencil method. This technique is adopted in the present work.

The paper is organized as follows; steering vector transformation technique is presented in section 2. Wideband DoA using this technique is illustrated in section 3. Section 4 presents the proposed frequency domain beamformer. Several simulation examples are shown in section 5. Section 6 is a final conclusion.

## 2. Steering Vector Transformation

A wideband received signal  $x(t)$  is incident on a uniform linear array of  $N$  elements and  $d$  interelement spacing as shown in fig. 1. The procedure is based on transforming the steering vector at the  $k^{th}$  frequency  $f_k$  into that at a specified reference frequency  $f_0$  using  $T(k)$  transformation matrix for  $M$  uniformly spaced directions covering the angular region [12].

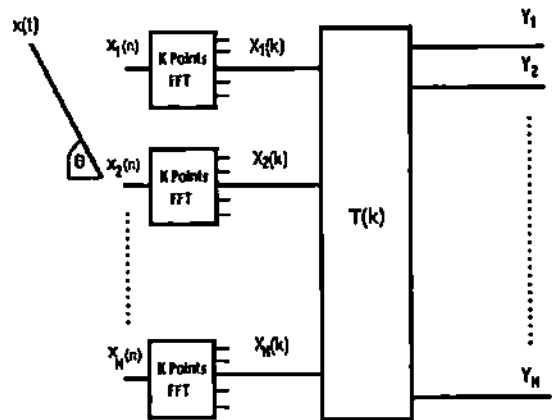

Fig.1 Steering vector transformation

The steering vector  $a$  at the  $k^{th}$  frequency  $f_k$  is defined by:

$$a(\theta, f_k) = [1, e^{j \frac{2\pi f_k d}{c} \sin(\theta)}, \dots, e^{j \frac{2\pi f_k d}{c} (N-1) \sin(\theta)}] \quad (1)$$

where  $k = 1, \dots, K$  and  $\theta$  is the received signal direction with respect to the array

broadside direction. The array steering matrix whose columns are the array steering vectors at the  $k^{th}$  frequency  $f_k$  for each of the  $M$  directions is defined by:

$$A(\theta, f_k) = [a(\theta_1, f_k), \dots, a(\theta_M, f_k)] \quad (2)$$

The steering matrix at the  $k^{th}$  frequency  $f_k$  is transformed to that computed at the reference frequency  $f_0$  using the transformation equation defined by:

$$A(\theta, f_0) = T(k)A(\theta, f_k) \quad (3)$$

The transformation matrix  $T(k)$  is obtained by minimizing the mean square error function  $\phi$  defined by:

$$\phi = (A(\theta, f_0) - T(k)A(\theta, f_k))^2 \quad (4)$$

The solution to this minimization problem is:

$$T(k) = A(\theta, f_0)A(\theta, f_k)^H (A(\theta, f_k)A(\theta, f_k)^H)^{-1} \quad (5)$$

where  $H$  is the hermitian transpose. The steering matrix  $A(\theta, f_0)$  is independent of the  $k^{th}$  frequency  $f_k$  and a single narrowband beamformer tuned at the reference frequency  $f_0$  can be used as will be considered in section 4.

### 3. Direction of Arrival Estimation (DoA)

An application to the steering vector transformation technique is the estimation of the DoA of wideband signals. Infact, there are different methods for the DoA estimation of narrowband signals. An efficient method is the matrix pencil method [11]. It is valid only for narrowband signals where the time delay can be approximated as a phase shift. It is

a snapshot by snapshot signal analysis method as it computes the received signal directly without the need to compute the covariance matrix reducing the computational complexity. For the DoA estimation of wideband signals [12] as shown in fig. 2, steering vector transformation is applied first to the received signal in order to maintain the steering vector independent of the  $k^{th}$  frequency  $f_k$  to be able to use the matrix pencil method.

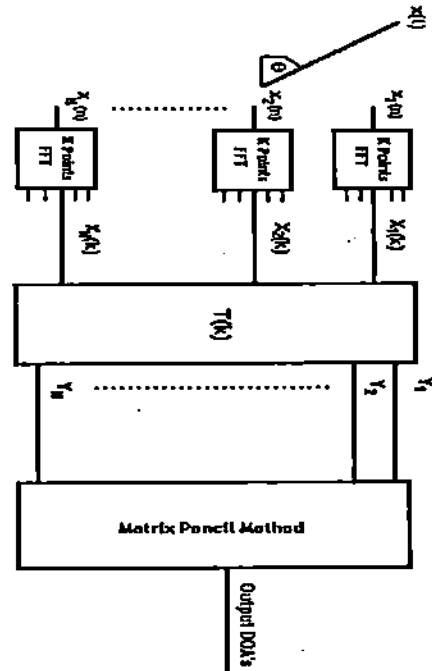

Fig.2 Wideband DoA using the steering vector transformation technique

### 4. The Proposed Frequency Domain Beamformer

Since narrowband beamforming is conceptually simpler than broadband beamforming, the conventional frequency domain beamformer is implemented by a narrowband decomposition structure whereby the signal received at each sensor is transformed into its frequency domain components using a fast Fourier

transform and each narrow band of frequencies is treated using an independent narrowband beamformer [6, 7] as shown in fig. 3. The narrowband beamformer weight at the  $k^{\text{th}}$  frequency  $f_k$  for the  $n^{\text{th}}$  sensor is defined by:

$$w_n(k) = a_n e^{-j \frac{2\pi(n-1)f_k d}{c} \sin(\theta_0)} \quad (6)$$

where  $n = 1, \dots, N$  and  $\theta_0$  is the desired signal direction, then the output of the  $k^{\text{th}}$  beamformer  $Y(k)$  is defined by:

$$Y(k) = \sum_{n=1}^N w_n(k) X_n(k) \quad (7)$$

where  $X_n(k)$  is the  $k^{\text{th}}$  frequency component of the input signal  $x(t)$  at  $n^{\text{th}}$  sensor. From equations (6) and (7), it is observed that for the conventional beamformer, the output  $Y(k)$  is dependent of the  $k^{\text{th}}$  frequency  $f_k$  at all directions within the angular region except the desired direction  $\theta_0$ .

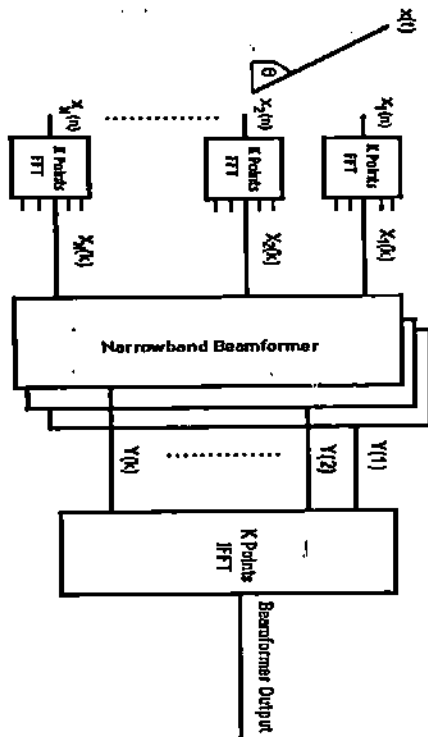

Fig. 3 The conventional frequency domain beamformer

In the present work, the steering vector transformation technique considered in section 2 is applied to the conventional frequency domain beamformer in order to enhance the frequency invariance of the mainlobe pattern. This proposed frequency domain beamformer is shown in fig. 4 where the  $k^{\text{th}}$  frequency component  $X(k)$  of the input signal  $x(t)$  is being transformed into the signal vector  $Y$  defined by:

$$Y = T(k) X(k) \quad (8)$$

where  $X(k) = [X_1(k) X_2(k) \dots X_N(k)]$ ,  $Y = [Y_1 Y_2 \dots Y_N]$  and  $T(k)$  is the transformation matrix as considered in section 2. Then from equation (8) and as considered before, the received signal vector  $X(k)$  is transformed into a fixed signal vector  $Y$  almost independent of the  $k^{\text{th}}$  frequency  $f_k$  at all directions within the angular region. A single narrowband beamformer tuned at the reference frequency  $f_0$  given in section 2 is then used. Then the narrowband beamformer weight used at any frequency  $f_k$  for the  $n^{\text{th}}$  sensor is defined by:

$$w_n = a_n e^{-j \frac{2\pi(n-1)f_0 d}{c} \sin(\theta_0)} \quad (9)$$

where  $n = 1, \dots, N$ . From equations (8) and (9), at any frequency  $f_k$ , both transformed signal vector  $Y$  and weight vector are independent of frequency. The beamformer output  $Z$  is:

$$Z = \sum_{n=1}^N w_n Y_n \quad (10)$$

From equation (10), the beamformer output is then also independent of frequency.

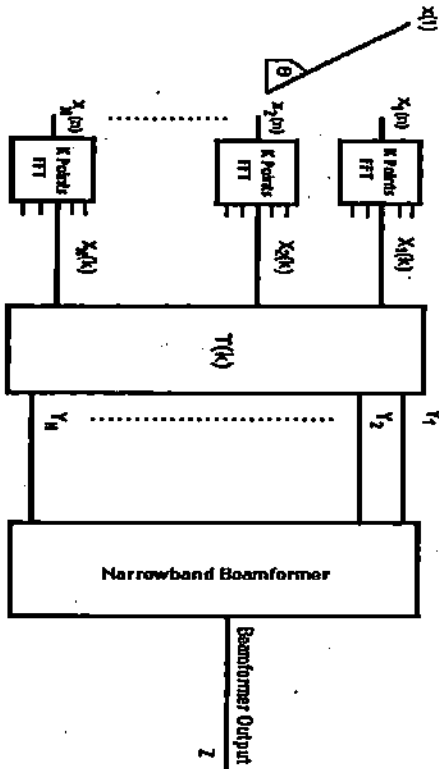

Fig. 4 The proposed frequency domain beamformer

### 5. Simulations

A uniform linear array of 10 elements with 0.06 m interelement spacing is used. Two signals of directions (0 and 20 degrees) assumed to be unknown are received by the array. The signal-to-noise ratio is about 20 dB. The beampattern is computed at 9 frequencies within the frequency band [1.5 GHz – 2.5 GHz]. Figure 5 shows the relation of estimated directions of arrival of the received signals with frequency.

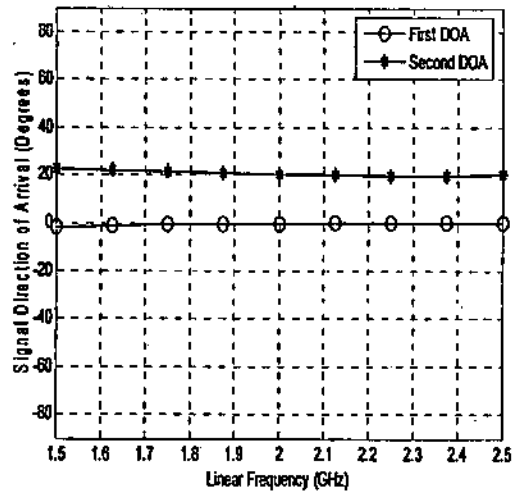

Fig. 5 Received signals estimated DoA with frequency

From fig. 5, it is observed that the DoA of the received signals estimated using the previous wideband DoA technique is almost independent of frequency except at low frequencies. Figures 6 and 7 show the beampattern of the conventional and proposed frequency domain beamformers respectively when the desired signal direction is 0 degrees.

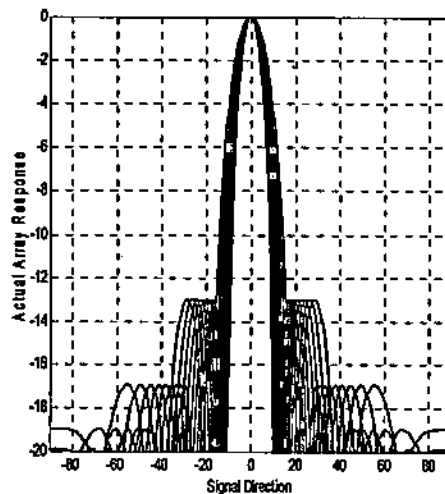

Fig. 6 The conventional beamformer beampattern at 9 frequencies within the design frequency band

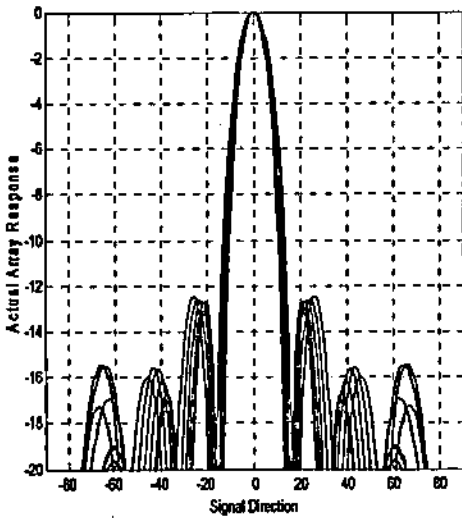

Fig. 7 The proposed beamformer beampattern at 9 frequencies within the design frequency band

The frequency invariant property of mainlobe pattern may be measured in terms of the mainlobe width deviation (MWD) defined by:

$$MWD = \frac{\theta_L - \theta_H}{\theta_L} \tag{11}$$

where  $\theta_L$  and  $\theta_H$  are the mainlobe widths at the lowest and highest frequencies respectively within the design frequency band. Mainlobe width is measured at -20 dB level relative to the maximum level. From fig. 6 mainlobe width deviation is 0.5 and 0.25 degrees from fig. 7. It is observed that the proposed beamformer has a better frequency invariant property of the mainlobe pattern than the conventional beamformer. However, sidelobe levels of the proposed beamformer slightly differ from that of the conventional one. Figure 8 shows the beampattern of the proposed beamformer receiving a desired signal whose DoA is assumed to be unknown and estimated using the previous wideband DoA estimation technique. A small error of 2 degrees is present in the estimated

mainlobe direction within the design frequency band. However, the main features of the beamformer beampattern are the same as that in fig. 7.

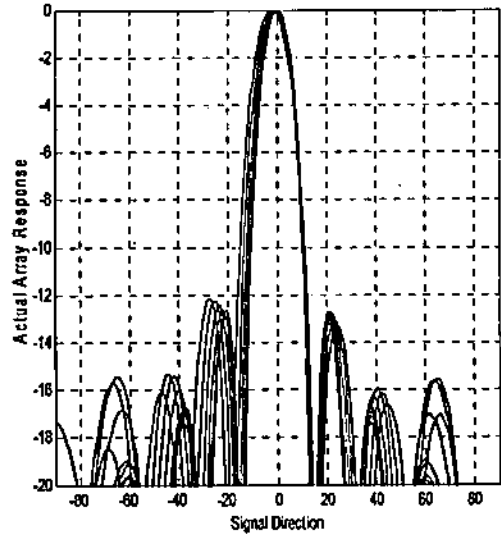

Fig. 8 The proposed beamformer beampattern at 9 frequencies within the design frequency band when the desired signal direction is assumed to be unknown

Next, the effect of varying the array size, the interelement spacing and the application of windows to both the conventional and proposed beamformers are studied.

### 5.1 The Effect of Variation of the Array Size

Figures 9 and 10 show the beampattern of both the conventional and proposed beamformers respectively when the array size increases up to 20 elements. From fig. 9, the mainlobe width is about 20 degrees. Also from fig. 10, the mainlobe width is the same as that from fig. 9 but the frequency invariant property of the mainlobe pattern is better. So as the array size increases, the proposed beamformer still has a better frequency invariant property of the mainlobe pattern than the conventional beamformer.

Comparing both figures 7 and 10, it is observed that the frequency invariant property of the mainlobe pattern is improved as the array size increases.

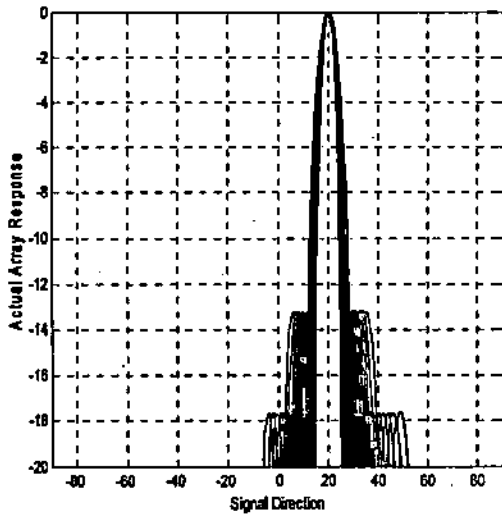

Fig. 9 The conventional beamformer beampattern at 9 frequencies within the design frequency band when the array size is 20 elements

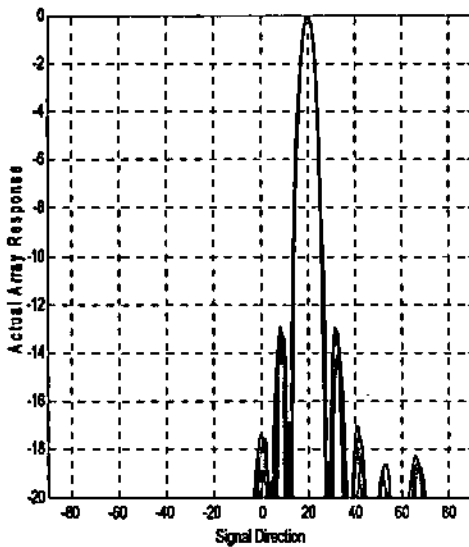

Fig. 10 The proposed beamformer beampattern at 9 frequencies within the design frequency band when the array size is 20 elements

## 5.2 The Effect of Variation of the interelement spacing

Figures 11 and 12 show the beampattern of both the conventional and proposed beamformers respectively when the interelement spacing decreases down to 0.04 m. From fig. 11, the mainlobe width is about 60 degrees while from fig. 12, the mainlobe width is about 45 degrees and the frequency invariant property of the mainlobe pattern is better. So as the interelement spacing decreases, the proposed beamformer still has a better frequency invariant property for the mainlobe pattern than the conventional beamformer. Comparing both figures 7 and 12, it is observed that the frequency invariant property of the mainlobe pattern is improved as the interelement spacing decreases.

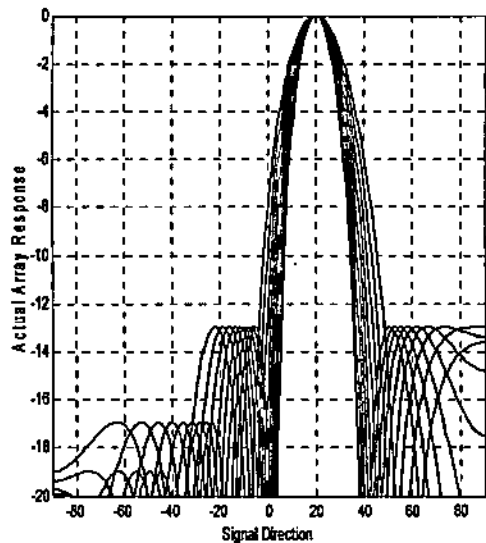

Fig. 11 The conventional beamformer beampattern at 9 frequencies within the design frequency band when the interelement spacing is 0.04 m



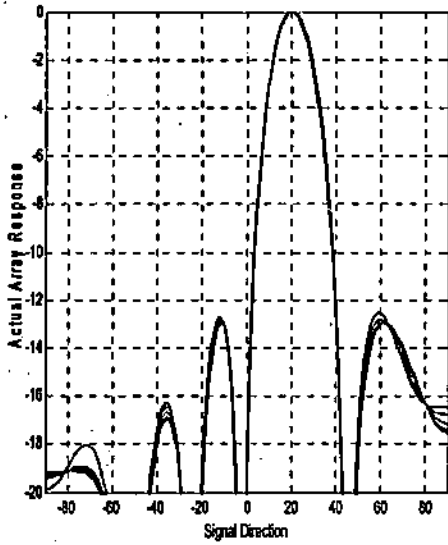

Fig. 12 The proposed beamformer beampattern at 9 frequencies within the design frequency band when the interelement spacing is 0.04 m

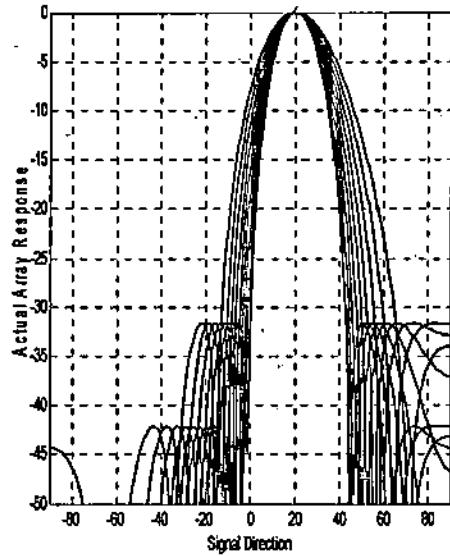

Fig. 13 The conventional beamformer beampattern at 9 frequencies within the design frequency band using the Hanning window

### 5.3 The Effect of Application of Windows

Windows are used to control sidelobe levels at the expense of increasing the mainlobe width [3]. Windows may be rectangular, Bartlett, Hanning, Blackman-Harris and Chebychev. In the present work, the Hanning and the Chebychev windows are considered. Mainlobe width is measured at -50 dB level relative to maximum. Figures 13 and 14 show the beampattern of both the conventional and proposed beamformers respectively using the Hanning window. From fig. 13, the mainlobe width is about 85 degrees and the sidelobe levels are less than -32 dB while from fig. 14, the mainlobe width is about 60 degrees, the sidelobe levels are less than -23 dB and the frequency invariant property of the mainlobe pattern is better.

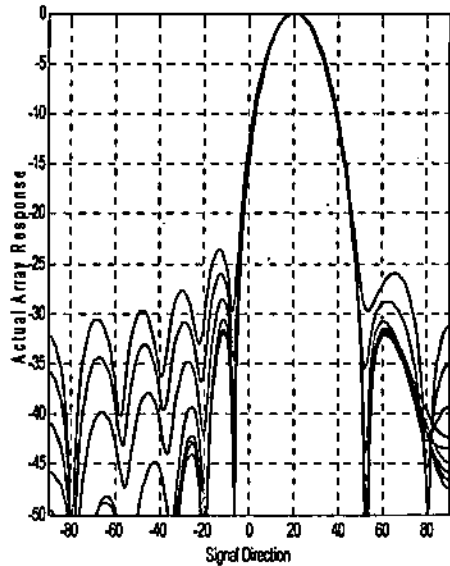

Fig. 14 The proposed beamformer beampattern at 9 frequencies within the design frequency band using the Hanning window

Figures 15 and 16 show the beampattern of both the conventional and proposed beamformers using the Chebychev window adjusted with sidelobe level  $\leq -30$  dB. From fig. 15, the

mainlobe width is about 65 degrees and the sidelobe level are less than -30 dB while from fig. 16, the mainlobe width is about 45 degrees, the sidelobe levels are less than -23 dB and the frequency invariant property of the mainlobe pattern is better. Also from fig. 16, sidelobe levels at low frequencies vary from -27 dB to -23 dB which are assumed to be fixed at -30 dB level. It is observed that using windows, the proposed beamformer still has a better frequency invariant property of the mainlobe pattern than the conventional beamformer. Also using the proposed beamformer rather than the conventional one, mainlobe width decreases and sidelobe levels increase.

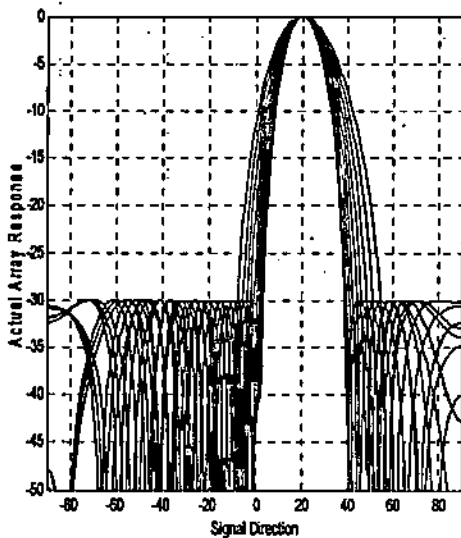

Fig. 15 The conventional beamformer beampattern at 9 frequencies within the design frequency band using the Chebychev window

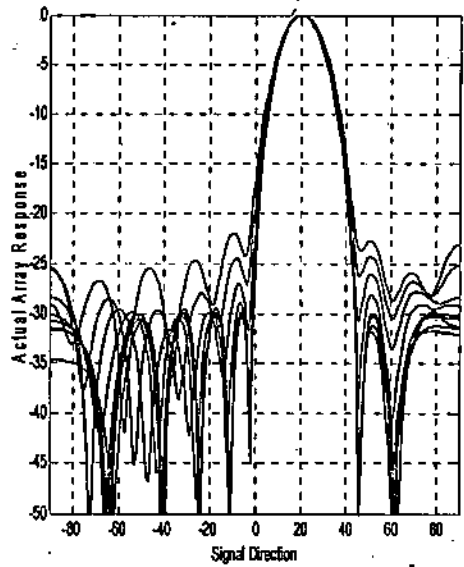

Fig. 16 The proposed beamformer beampattern at 9 frequencies within the design frequency band using the Chebychev window

## 6. Conclusions

A steering vector transformation technique is applied to the conventional frequency domain beamformer to enhance the frequency invariance of the mainlobe pattern. It is observed that the proposed beamformer has a better frequency invariant property of the mainlobe pattern than the conventional beamformer. However, sidelobe levels of the proposed beamformer slightly differ from that of the conventional one. As the array size increases or the interelement spacing decreases, the proposed beamformer still has a better frequency invariant property of the mainlobe pattern than the conventional beamformer. Finally, using windows, a better frequency invariant property of the mainlobe pattern is obtained by the proposed beamformer than the conventional one.

## References

- [1] H.L. Van Trees, *Optimum Array Processing*, John Wiley & Sons, 2002.
- [2] L.C. Godara, *Smart Antennas*, CRC Press LLC, 2004.
- [3] Allen and M. Ghavami, *Adaptive Array Systems*, John Wiley & Sons, 2005.
- [4] D.B. Ward, R.A. Kennedy and R.C. Williamson, "Theory and Design of Broadband Sensor Arrays with Frequency Invariant Far-Field Beam Patterns", *J. Acoustical Society of America*, vol. 97, issue 2, pp. 1023-1034, February 1995.
- [5] D.B. Ward, R.A. Kennedy and R.C. Williamson, "FIR Filter Design for Frequency Invariant Beamformers", *IEEE signal processing letters*, vol. 3, issue 3, pp. 69-71, March 1996.
- [6] T.D. Hong and P. Russer, "Signal Processing for Wideband Smart Antenna Array Applications", *IEEE Microwave Magazine*, vol. 5, issue 1, pp. 57-67, March 2004.
- [7] B.P. Cheung, "Simulation of Adaptive Array Algorithms for OFDM and Adaptive Vector OFDM Systems", M.Sc. Dissertation, Blacksburg, Virginia, September 2002.
- [8] M.E. Bialkowski and M. Uthansaku, "A Wideband Smart Antenna Employing Spatial Signal Processing", *Journal of Telecommunications and Information Technology*, issue 1, pp. 13-17, National Institute of Telecommunications, Poland, January 2007.
- [9] W. Liu, R. Wu and R.J. Langley, "Design and Analysis of Broadband Beamspace Adaptive Arrays", *IEEE Transactions on Antennas and Propagation*, vol. 55, issue 12, pp. 3413-3420, December 2007.
- [10] W. Liu, S. Weiss, and L. Hanzo, "A Generalized Sidelobe Canceller Employing Two-Dimensional Frequency Invariant Filters", *IEEE Transactions on Antennas and Propagation*, vol. 53, issue 7, pp. 2339-2343, July 2005.
- [11] H. Ouibrahim, D.D. Weiner and T.K. Sarkar, "A Generalized Approach to Direction Finding", *IEEE Transactions on Acoustics, Speech and Signal Processing*, vol. 36, issue 4, pp. 610-612, April 1988.
- [12] Y.S. Yoon, "Direction of Arrival Estimation of Wideband Sources Using Sensor Arrays", Ph.D. Dissertation, Georgia Institute of Technology, July 2004.