

3-18-2021

Application of Artificial Neural Network in Predicting Circular Knitted Fabric Appearance.

Ihab El-Sayed

Faculty of Engineering., Jazan University., Kingdom of Saudi Arabia.

Follow this and additional works at: <https://mej.researchcommons.org/home>

Recommended Citation

El-Sayed, Ihab (2021) "Application of Artificial Neural Network in Predicting Circular Knitted Fabric Appearance.," *Mansoura Engineering Journal*: Vol. 34 : Iss. 3 , Article 11.

Available at: <https://doi.org/10.21608/bfemu.2021.157722>

This Original Study is brought to you for free and open access by Mansoura Engineering Journal. It has been accepted for inclusion in Mansoura Engineering Journal by an authorized editor of Mansoura Engineering Journal. For more information, please contact mej@mans.edu.eg.

APPLICATION OF ARTIFICIAL NEURAL NETWORK IN PREDICTING CIRCULAR KNITTED FABRIC APPEARANCE

Ihab Mohammad El-Sayed,

Faculty of Engineering, Jazan University, Kingdom of Saudi Arabia.

تطبيق الشبكة العصبية الصناعية على التنبؤ بمظهرية أقمشة التريكو الدائري

الخلاصة:

الغرض الرئيسي من هذا البحث هو تطوير نظام للتنبؤ بمظهرية الأقمشة المصنوعة بواسطة ماكينات التريكو الدائري من خلال استخدام خواص الخيوط المستخدمة في صناعة تلك الأقمشة.

سيتم استخدام طريقة جديدة مبتكرة يتم استعمال الشبكات العصبية الصناعية فيها للتنبؤ بالمظهرية بعد ادخال أكبر عدد متاح من خواص الخيوط المستخدمة في صناعة تلك الأقمشة على ماكينات التريكو الدائري . حيث يتم أخذ صورة للقماش و هو على الماكينة و ارسالها للحاسب الآلي لمعالجتها و تحويله الى صورة رقمية و ايجاد علاقة معامل انتظامية للمظهرية الخاصة بالقماش في هذه الصورة بهذا الخيط. ثم يتم تكرار العملية باستخدام 14 خيط. مختلف. و بعمل اختبارات للخيوط يتم استخدام نتائج الاختبارات للتنبؤ بمظهرية الخيط وبالتالي مقارنتها مع نتائج الصورة الرقمية.

ABSTRACT: The main purpose of this paper is to develop a system to predict the amount of cloudiness and non-homogeneous appearance of the circular knitted fabric, by utilizing the various cotton yarn quality characteristics which produced that fabric .

A novel approach was developed using Artificial Neural Network (ANN) and satisfied results were obtained. A learning phase for the system was initially conducted on circular knitting machine fitted with an image processing system to capture an on-line image of the weft knitted fabric which was produced using one yarn cone (the machine was modified and adapted to use one cone instead of 24 yarn cones) in order to eliminate yarn cone to cone variation and to differentiate between 14 different types of yarn from 14 different producers.

All kinds of physical tests on yarn quality characteristics were conducted on the yarns in order to be used as a comprehensive input set of data for the prediction of the appearance and cloudiness of knitted fabric. The developed (ANN) System was successfully capable of predicting the appearance and cloudiness with satisfied agreement with actual results.

1 INTRODUCTION

Many textile industries now are in increasing concerns about the fabric appearance, cloudiness, non-homogeneity and non-uniformity. Textile manufacturers specially Lingerie producers, they prefer the most clear appearance of knitted cotton fabric (which is similar to the appearance of polyester fabric produced from Microfiber in its clear and transparent form). The later has no salt and pepper effect which the natural cotton has.

This appearance (in the case of the cotton) is called cloudiness or non-uniformity and non-homogeneity. It does not have a certain pattern. It changes from cotton type to cotton type depending on the origin of the cotton, the ginning, the mixing process and may be all the preparation processes pre and post spinning. Dias, T.^{1,2} developed an on-line fault detection for weft knitting machines in ITV Denkendorf, Stuttgart University, Germany. His system was used to study and analyze fabric appearance. El-Sayed, I³ and Al-Kayal, M⁴ measured fabric discrepancy using on yarn cone on circular knitting machine and correlate the weft knitted discrepancy index to the human expert judgment and yarn quality characteristics. Weickert, J⁵ reported that The cloudiness of fabrics is a scale-phenomenon which can be analyzed sufficiently well using a Laplacian pyramid decomposition. The pyramid should be modified at boundaries in order to reduce errors induced by these values. As a measure of cloudiness, one may use a weighted average of the variances at all scales, with weights according to the human perception. The obtained model reaches the qualities of a human assessor, and it is fast enough for online grading. Therefore, future research ran focus on the second quality relevant feature of fabrics, the grading of stripes. Sette and Boulart⁶ used neural networks for the quality

assessment and fault detection. Semnani and et al.⁷ presented a method for evaluation of knitted fabric appearance. They attempted to present a definition for apparent quality of weft knitted fabrics and their used yarns using the image analysis method and linear functions, which are calculated by neural networks. The results showed that the correlation between apparent quality of knitted fabrics and their yarns is very strong. Semnani, D., and Sheikhzadeh, M.⁸ reported that fabric regularity is strongly related to yarn regularity, they also reported that Usually, distorted stitches as surface irregularity events are observed in knitted fabrics of spun blended cotton yarns because of frictional properties of these yarns.

The main objective of this paper is to predict fabric regularity using different cotton yarns from different producer all over the world. It utilized a sample from each yarn (a single cone) to produce a weft knitted fabric on circular knitted machine.

Then the image of the fabric was captured while produced on-line, then it was analyzed in order to get a value for each appearance or non-uniformity, then it was ranked. The Ranking was executed for the 14 (fourteen) different fabrics in ascending order according to the resulted non-uniformity or non-homogeneity level from the image processing system.

In the last decade knitted apparel have made impressive improvement in appearance and quality. In certain range of this industry, a need rose to compare appearance of fabric produced using natural material and synthetic material.

Cloudiness which is a characteristic covering of fabric surfaces (particularly in the open spaces between yarns) by fuzzy fibres protruding from yarns, is an important factor in the quality of many

types of staple fiber fabrics of open knit. Producers and consumer of knitted fabric looking forward to have naturally produced fabric with same quality, appearance and no cloudiness same like fabric produced from synthetics yarns. It is almost impossible due to the nature of the natural yarn and the way and technology of its manufacturing.

Weft knitted fabric is a conversion system whereby yarn loops are intermeshed to form a fabric. The appearance of such fabric when seeing through a steady light source will look cloudy and non homogeneous due to the variation of the quality characteristics of the yarn used. Which yarn parameter is affecting more or less the appearance or cloudiness of the knitted fabric. No such research has tackled this problem.

2 RESEARCH METHODOLOGY

The main objective of this paper is to develop (ANN) system. This system will be used for predicting the cloudiness or fabric irregularity of any weft knitted fabric. The system will utilize most of the yarn quality characteristics used to produce these fabrics. Also a panel of knitting experts had to view the resulted fabric and arrange them in the same order from the most uniform one to the least uniform appearance in an ascending order. The proposed (ANN) should reproduce the same results as the knitted experts. The output of the (ANN) will be considered as a performance indicator for the success of the system.

Another objective of this paper is to verify the methodology of the way the image processing system is evaluating the non-uniformity and correlate to the same judgement by the knitting experts. Also comparison was made between quality parameters of knitted Fabric produced from Rotor and Ring Spun Yarn. This research project was initiated in the institute of Textile and Process

Technology, in Stuttgart University, Germany "Institut fuer Textil und Verfahrenstechnik" (ITV) Denkendorf, Stuttgart – Germany.

The Project was initially developed in order to detect and classify five different fault types of knitted fabrics which are thick and thin places, holes, neps and needle marks. Then it was developed to investigate the amount of fabric cloudiness or non-homogeneity appearing by calculating what was called span width. This can be described as the different between the maximum pixel value and the minimum pixel value of the fabric image. The light was passing through the knitted fabric during the knitting process, the scanner was capturing the image and send it to the computer to process it. A software was developed to calculate this value of the cloudiness. A simple image processing tool was introduced to analyze the image.

2.1 Experimental Apparatus

An image was developed during the fabric production, it was transformed to a digital file and then it was analysed mathematically and statistically to find the overall index of cloudiness.

A schematic diagram for the image processing system is shown in figure 1. The Light from tube (2) travels through the weft knitted tube (3) and collimated by the Fresnel Lens (1) to be received by the Mirror Wheel (4) which rotate and guide the light beam to the Photo Diode (6) passing through the Collimated Lens (5). The Photo Diode output is connected to an electronic circuits with special analogue to digital converter (A/D). The later output is sampled, averaged and stored on hard disk using a special designed personal computer and suitable software. The logged data is then analyzed and computed, correlated with the fabric appearance.

2.2 Experimental Materials and Yarns

Fourteen different yarns were used from different yarn producers with different spinning technology either Rotor or Ring Spun Yarn. Also different yarn preparation methods were investigated to establish the effect of carded and combed yarn on the digital image and consequently on the cloudiness index. All fourteen yarns were randomly sampled and three cones from each type were selected and sent to the central lab of ITV.

The yarn's laboratory was instructed to leave them in a standard atmosphere of temperature and humidity to be conditioned. Then to be tested using the available instruments in laboratory. Three cones from each yarn type or producer were sampled and the average of those three cones were reported.

About 40 Yarns' Quality Characteristics were tested (3cones x 10 times/yarn), collected and arranged in a table whose column head was the yarn producer, spinning technology Rotor or Ring as well as preparation type carded or combed and its rows was different yarn quality characteristics – the following table (table 1) show the different characteristics used in this research paper.

The Yarn was marked as follows: see table.1

2.3 Knitting Process and Capturing Image

In order to avoid the variation between yarn cones, and for the reason of obtaining only the variation in knitted fabric appearance due to the variation in one yarn cone, it was decided to eliminate all source of variations between yarns from the same producer. Therefore the knitting machine used in the investigation was transferred to knit using only one yarn cones and not multiple cone as in normal production . The productivity was very

low but for the purpose of the research it was accepted.

Each yarn cone was processed separately on the machine and the optical system was allowed to investigate the produced fabric. A scanner was installed outside the machine as illustrated in figure 1. The output of the scanner was then delivered to an Analogue / Digital converter card which was in turn convert the data using a specially designed and written software, it was capable of logging and storing these data as an ASCII readable file.

The ASCII file was named according to the ranking of the yarn cones used and then statistically analyzed in order to obtain the index of cloudiness of each type of yarn.

2.4 Neural Network

The Analyzed Scanner data was sorted in one row under the end of each column which represents yarn quality characteristics results. In other words the first 40 cells in any column were yarn properties and the cell number 41 were representing the resulting cloudiness index from this yarn.

The Multi regression analysis showed that the best correlation between yarn properties and the resulted appearance of knitted fabric was "snarl effect" El-Sayed,I.³ Which could be interpreted as many dark places coming in optical transparency and affect the amount of light passed through the fibre to the scanner?

However, this did not satisfy the researcher, and it was decided to use another tool which is the Artificial Neural Network (ANN).

The (ANN) is often applied to solve prediction and classification problems, especially in the prediction of nonlinear structural systems, Sette S., Boullart, L. ⁶. A back-propagation

artificial neural network with three layers : input layer, output layer, and hidden layer, was used in this study. Its' configuration is shown in Figure 2.

Input variables include 40 yarn quality characteristics measured by USTER system

It is well known since 1984 that this tool is simulation to what happens in nature and specially with the Humanbeing. ANN could be utilized in the textile research as a powerful tool for prediction of multivariate process. The Neural Network in nature consists of elements. In research we could apply on the resulted data in the same manner. The network function is determined largely by the connections between elements. One can train a neural network to perform a particular function by adjusting the values of the connections (weights) between elements.

Commonly neural networks are adjusted, or trained, so that a particular input leads to a specific target output. Such a situation is shown in Figure 3. There, the network is adjusted, based on a comparison of the output and the target, until the network output matches the target. Typically many such input/target pairs are needed to train a network.

Neural networks have been trained to perform complex functions in various fields, including pattern recognition, identification, classification, speech, vision, and control systems.

Today neural networks can be trained to solve problems that are difficult for conventional computers or human beings. Throughout the toolbox emphasis is placed on neural network paradigms that build up to or are themselves used in engineering, financial, and other practical applications. Neural networks are good at fitting functions and recognizing patterns. In fact, there is a proof that a fairly simple neural network can fit any practical function. In this paper, artificial neural

network (ANN) was used to predict fabric appearance as a target from yarn quality characteristics as input. As it is well known about (ANN) The system must be trained first on a set of known input and its known target. This is known as learning phase The Data were analyzed using the Neural Network tool (NNtool) form Matlab. It was decided to select 7 yarns to be used as training set for ANN and the other 7 yarns to be used as a test. Table 2 shows some of these results

After launching the NNtool from command menu in Matlab. The Network/Data Manager screen appears. It asks the user to enter the Input Data, in this paper case this will be a matrix 40x7 (40 different yarn properties) for 7 (seven) different yarns types. Then the Target Data were entered 1x7 (7 cloudiness index) for the entire 7 yarns under training. This could be done in Matlab by different methods. The one used was importing the input data and the target data from the work space. Then a new network were selected using the New button at the bottom of the Network/Data Manager screen. A new screen appears with title "Create Network or Data".

A name should be given to the network, suitable network type should be selected, the input data, target data, training function, adaption learning function, performance function, Number of Layers, Properties for each Layer Like (Number of Neurons for each) and transfer function. After selecting all parameters and settings, the button Create should be pressed, then closing these menu and back to the Network/Data Manager . The network which were just created will appear in the network lists, it should be clicked and then the button open should be pressed. The following figure will appear

Figure 4 shows the training curve trying to reach a zero error level while it is 3.4×10^{-13} after 100 epochs.

Table 4 shows the different setting and trials for the network used in this research paper in order to find the best fitting function and parameters to predict our targets from our training data. Many different parameters were tried, only 10 of them will be illustrated here. In Table 5, the first column shows trial number, second column shows "Train" which means what item no.(yarn or group of yarns) were taken as a training group. Then "Test" shows what item numbers were taken and used for testing. "Hid_Layer" shows the number of hidden Layer used in the (ANN) system proposed. "1No_Neuron1" shows how many neurons in the first hidden layer were used. "2No_Neuron2" indicates the number of neurons in the second hidden layer.

3 RESULTS AND DISCUSSION

Most of Uster's yarn quality characteristics have been executed. Almost all of the quality parameters measured by Uster Technologies yarn testing equipment were performed and used as input set of data for the ANN system while the developed index of knitted fabric cloudiness (Span Width which will be called later: Fabric Cloudiness Index) as the output set.

The Fabric Cloudiness Index (FCI) agreed with the visual ranking executed by the knitting experts. In other words the manual ranking of appearance agreed with the computerized ranking. Then, it was decided to feed the FCI to the ANN system directly as a target output in the training phase. The input data for the training in the ANN were the data measured by Uster results. These data were arranged and entered to the system. The data included the yarn count , mass variation, yarn elongation, yarn tenacity, yarn imperfection and many other yarn quality characteristics were taken into consideration. Table 5 shows the original

data compared to the results of the predicted (ANN) system. The results are satisfied except the yarn "C" because its ring spun and carded. While the yarn "A" is also ring spun but combed. see Table 5

4 CONCLUSION

The proposed Artificial Neural Network tool succeeded in predicting the Cloudiness index of the knitted fabric from the properties of the yarn used in the knitting process.

The Artificial Neural Network (ANN) method proved that its capability of predicting the Fabric Cloudiness Index (FCI) from its yarn characteristics is in good agreement of the scanned images of that knitted fabric. The results were compared with the results came out from Knitting Experts and it was in a good correlation. The error percentage could be considered negligible compared to the variety of yarn used. KFA has a good relationship with the yarn characteristics used during the weft knitting process. It is not advisable to take the individual yarn characteristics values into consideration rather than take the overall weight and contribution of multiple yarn characteristics in wider domain or broader band. The three different methods of judging the cloudiness and appearance of knitted fabric namely (firstly visually by knitting experts, secondly electronically by image processing, and finally by artificial intelligent using ANN tool) were in satisfied range of agreement.

5 SUGGESTION FOR FUTURE WORK

It is highly recommended that the trial should be repeated using either only ring spun yarn or only rotor spun yarn. This surely will improve the overall learning process of the back propagation of the

ANN. Also it is highly recommended to repeat the whole trial using a unique yarn preparation method, either only carded for the whole group of yarn under test or only combed yarn. The preparation technology used must be the same for all yarns undergoing that process, especially when using different yarn count. On the other hand, the project might be applied to woven fabric by installing a suitable imaging system.

REFERENCES

- 1- Dias, P.K.T., Tauber, N., Bühler, G., Guse, R.; Text. Prax. Int., 33 - 34 (1986)
- 2- Dias, P.K.T. " Automatic Fault . Detection in Circular Knitting Machines", "Institut fuer Textil und Verfahrens Technics" (ITV) Denkendorf , Stuttgart University, Germany, PhD. Thesis, 1987.
- 3- El-Sayed, I. Relationship between Yarn characteristics and Cloudiness appearance in circular knitting fabrics. (ITV –Denkendorf – Stuttgart – Germany), Diplom Arbeit (Technical Report) October 1991.
- 4- Manfred Al-Kayal, "Institut fuer Textil und Verfahrens Technics" (ITV) Denkendorf , Stuttgart University, Germany, Diplom Arbeit 1989.
- 5- Weickert, J., " A Model for the Cloudiness of Fabric " , Laboratory of Technomathematics, University of Kaiserslautern, Bericht Nr, 131 , February 1995
- 6- Sette S., Boullart, L. "Fault detection and quality assessment in textiles by means of neural nets"., International Journal of Clothing Science and Technology, Vol. 8 No. 1/2 pp. 73-83, 1996.
- 7- D. Semnani a; M. Latifi a; M. A. Tehran a; B. Pourdeyhimi b; A. A. Merati c , "Effect of yarn appearance on apparent quality of weft knitted fabric", Journal of the Textile Institute, JOTI 2005 Vol. 96 No. 5 pp. 295–301, January 2005.
- 8- D. Semnani , Sheikhzadeh, M., " Online Control of Knitted Fabric Quality Loop Length Control", IJECSE Vol. 1 No. 4, pp 213-218, 2007.

ACKNOWLEDGMENT

The author thanks the "Institut fuer Textil und Verfahrenstechnik" (ITV) Denkendorf, Stuttgart – Germany, for the effort and contribution and their support during the time of collecting the data.

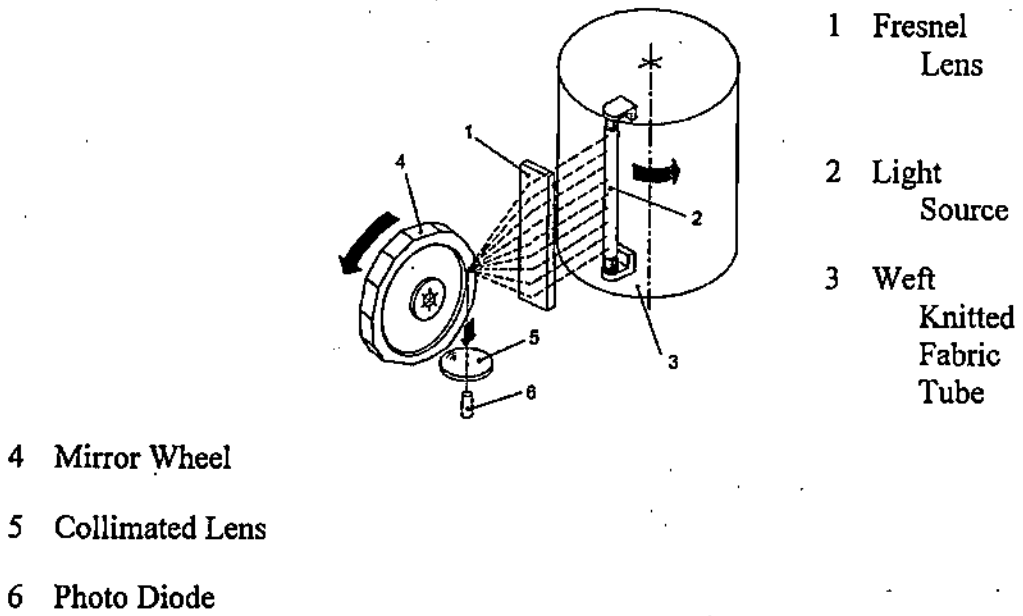

Figure 1

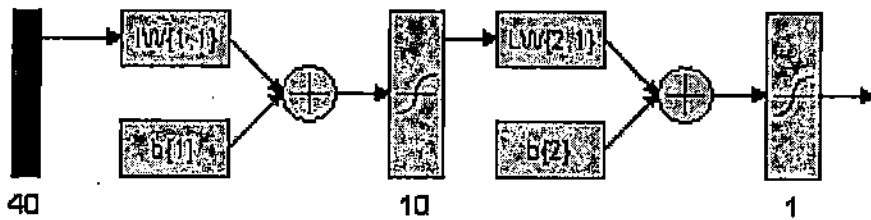

Figure 2

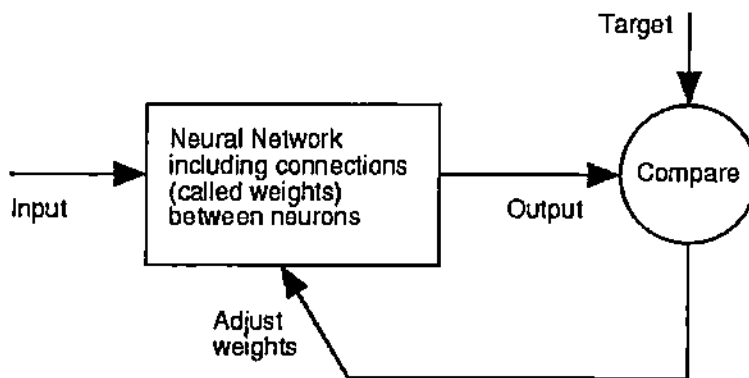

Figure 3

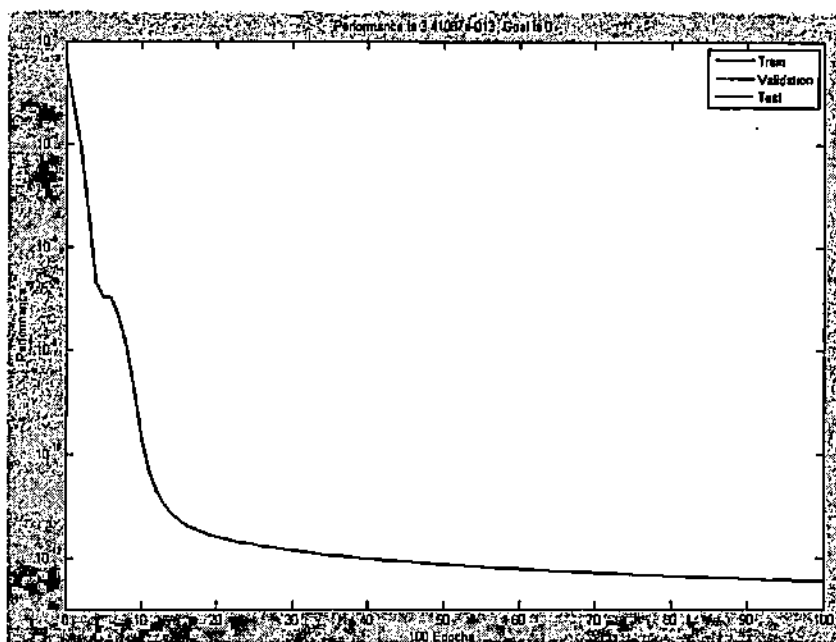

Figure 4

Table 1

Producer	A	C	G	B	D	E	F	L	M	H	K	J	I	N
Spinn. Tech	Ring	Ring	Rotor	Rotor	Rotor	Rotor	Rotor	Rotor	Rotor	Rotor	Rotor	Rotor	Rotor	Ring
Preparation	Combed	Carded												
Count	50	50	50	50	50	50	50	50	50	50	54	56	58	56
Item No.	1	2	3	4	5	6	7	8	9	10	11	12	13	14

Table 2

A	C	G	B	D	E	F	Item
302.00	413	297	288.00	256.00	269.00	255.00	Orig_Data
305.00	304.511	301.6668	276.58	302.77	304.51	254.70	NNTool_Out
3.00	-108.49	4.67	-11.42	46.77	35.51	-0.30	Difference from Orig
0.01	-0.26	0.02	-0.04	0.18	0.13	0.00	Error
0.99%	-26.27%	1.57%	-3.97%	18.27%	13.20%	-0.12%	% Error

Table 3

Item No.	1	2	3	4	5	6	7	8	9	10	11	12	13	14
Producer	A	C	G	B	D	E	F	L	M	H	K	J		
Cloudiness	302	413	297	288	256	269	255	284	282	273	267	254		

Table 4

Trial No.	Train	Test	Network	Hid_Layer	1No_Neuron1	2No_Neuron2
1	8-14	1,4-7	Default	1	10	
2	8-14	1,4-7	2hidden	2	27	14
3	8-14	1,4-7	2hidden	2	33	14
4	8-14	1,4-7	2hidden	2	33	23
5	8-14	1,4-7	2hidden	2	33	18
6	8-14	1-7	Default	1	10	
7	8-14	1-7	2hidden	2	27	14
8	8-14	1-7	cascade			
9	8-14/521	1-7/521	2hidden	2	27	14
10	8-14/1100	1-7/360	2hidden	2	27	14

Table 5

A	C	G	B	D	E	F	Item
302.00	413.00	297.00	288.00	256.00	269.00	255.00	Orig_Data
305.00	305.00	255.52	258.90	267.72	257.82	254.06	NNTool_Out
3.00	-108.00	-41.48	-29.10	11.72	-11.18	-0.94	Difference from Orig
0.01	-0.26	-0.14	-0.10	0.05	-0.04	0.00	Error
0.01	-0.26	-0.14	-0.10	0.05	-0.04	0.00	% Error