

12-1-2020

Design and Construction of a Two Axes Sun Tracker Prototype with a Real Time Controller and Hybrid Stepper Motors.

Helmy Gad

Prof. at Mechanical Power Engineering - Faculty of Engineering - Mansoura University,
he_gad@yahoo.com

Safya El-Gayar

Senior researcher, Agric. Eng. Res. Inst., A. R. C, Giza, P.O.256, Egypt, safelgyar@yahoo.com

Hesham Helmy Gad

Computers and Systems Department, Faculty of Engineering, Mansoura University, El-Mansoura 35516, Egypt

Follow this and additional works at: <https://mej.researchcommons.org/home>

Recommended Citation

Gad, Helmy; El-Gayar, Safya; and Gad, Hesham Helmy (2020) "Design and Construction of a Two Axes Sun Tracker Prototype with a Real Time Controller and Hybrid Stepper Motors.," *Mansoura Engineering Journal*: Vol. 34 : Iss. 4 , Article 14.

Available at: <https://doi.org/10.21608/bfemu.2020.126761>

This Original Study is brought to you for free and open access by Mansoura Engineering Journal. It has been accepted for inclusion in Mansoura Engineering Journal by an authorized editor of Mansoura Engineering Journal. For more information, please contact mej@mans.edu.eg.

DESIGN AND CONSTRUCTION OF A TWO AXES SUN TRACKER PROTOTYPE WITH A REAL TIME CONTROLLER AND HYBRID STEPPER MOTORS

تصميم وإنشاء نموذج متتبع شمسي على محورين بوحدة تحكم في الوقت الحقيقي ومحركات خطوية هجينة

Helmy E. Gad¹, Safya M. El-Gayar² and Hesham E. Gad³

¹ Mechanical Power Engineering Department, Faculty of Engineering,
Mansoura University, El-Mansoura 35516, Egypt, E-mail: he_gad@yahoo.com

² Senior researcher, Agric. Eng. Res. Inst., A. R. C, Giza, P.O. 256, Egypt
E-mail: safelgyar@yahoo.com

³ Computers and Systems Department, Faculty of Engineering,
Mansoura University, El-Mansoura 35516, Egypt, E-mail: hmwork2004@hotmail.com

ملخص البحث:

تتبع الشمس أصبح من الضروريات لزيادة كفاءة وتقليل تكاليف أنظمة الخلايا الشمسية وكذلك المركبات الشمسية. لذلك، يستخدم هذا النظام في تعظيم الإشعاع الشمسي المباشر على أسطح هذه الأجهزة. وهذا أصبح من الأساسيات لضخ المياه للري وتوليد القوى بالطاقة الشمسية. في الدراسة الحالية، تم تصميم وإنشاء واختبار نموذج جديد لمتتبع شمسي (هليوستات). هذا المتتبع الشمسي يتبع الشمس على محورين ويستخدم وحدة تحكم في الوقت الحقيقي ومحركات خطوية هجينة. تعتبر وحدة التحكم المستخدمة هنا (Microcontroller) منخفضة التكاليف بالمقارنة بأجهزة التحكم الأخرى. هذا الـ Microcontroller يوفر عدد كبير من أطراف الدخول/الخروج للتحكم في المحركات الخطوية الهجينة والشاشة (LCD). أيضا، كبر ذاكرته الداخلية و Processing power تجعله جهازا مناسباً جدا لحل معادلات الطاقة الشمسية في الزمن الحقيقي. يعتبر متتبع الشمس المقترح أكثر بساطة وثقة في التشغيل بالمقارنة بالـ (PLC) Programmable logic controller و Digital signal processors وكذلك Electro-optical controlled systems. أظهرت النتائج أن هذا الجهاز (المتتبع الشمسي) يتتبع الشمس بصورة دقيقة وأن نتائج القياسات التجريبية قريبة جداً من النتائج النظرية. كما أن المميزات العديدة للمحركات الخطوية الهجينة ونظام التحكم تعتبر مناسبة لهذه التطبيقات. وبالتالي، يعتبر متتبع الشمس هذا مناسباً أيضا لألواح الخلايا الشمسية المستخدمة في ضخ المياه وتوليد القوى وكذلك المركبات الشمسية من النوع الطبقي.

ABSTRACT

The sun tracking became of high necessity for increasing the efficiency and reducing the cost of photovoltaic systems and solar concentrators. This system is used for maximizing the normal incident direct solar radiation on the surface of these devises. This is essential in solar water pumping for irrigation and power generation. In the present study, a new prototype sun tracker (heliostat) is designed, constructed and tested. This sun tracker tracks the sun on two axes and uses a real time control unit and hybrid stepper motors. The control unit uses a low cost microcontroller compared to the other controllers. The microcontroller provides a large number of input/output pins for controlling the hybrid stepper motors and the LCD screen. Also, its internal memory size and the processing power are high making it the most suitable device for solving solar energy equations in real time. The proposed sun tracker is seen to be simpler in operation and more reliable than the PLC, microprocessor and electro-optical controlled systems. Results show that this sun tracker has a good accuracy for tracking the sun and that the experimental data are closely fit the theoretical results. Hybrid stepper motors with their advantages and the control system are suitable for these applications. Thus, this sun tracker is also seen to be suitable for the photovoltaic panel used for solar pumping, power generation and the dish type solar concentrators.

Keywords: Design, construction, real time, two axes, sun tracker, hybrid stepper motors.

INTRODUCTION

The energy needs and costs have increased in recent years, while the process of energy production is harmful to the environment. Solar energy is the best choice since it is clean, renewable and abundant in several parts of our Arab world. Photovoltaic panels convert solar energy directly into direct current electrical energy for water pumping in irrigation and power generation. The amount of electrical energy obtained from the photovoltaic systems is directly proportional to the intensity of solar radiation falling on the panel surface. However, the change observed in solar energy does not occur linearly, for this reason it is desired that the solar panels have a solar tracking unit especially in the grid connected systems.

Many classes of sun trackers can be distinguished depending on the classification criteria. Regarding the movement capability, three main types of sun trackers exist; fixed surfaces, one axis trackers Poulek and Libra [1] and two axes trackers Abdallah and Salem [2]. Sun tracking systems are designed to track the sun on a single axis according to the solar azimuth angle, or on two axes according to the solar azimuth and altitude angles. The main difference among them is the ability to reduce the pointing error, increasing the daily irradiation on the solar cells surface and thus the produced electric energy. Regarding control method, the main types of solar trackers are: passive, microprocessor and electro-optical controlled units. The first type does not use any electronic control or motor mathematical formulae to predict the sun's movement and does not need sense the sunlight. An example of this kind of sun tracker can be found in Roth et al. [3]. The second type uses electro-optical control system that uses a sensor (e.g., auxiliary bifacial solar cell panel and pyrliometer) to estimate the sun's real position is used in the control algorithm reported by Abdallah and Salem [2] and Clifford and Eastwood [4].

Various studies were conducted on the sun tracking systems using a number of different

techniques. Rubio et al. [5] presented a control system of a sun tracker that is able to follow the sun with high accuracy without the necessity of either a precise procedure of installation or recalibration. A hybrid tracking system that consists of a combination of open loop tracking strategies based on solar movement models and closed loop strategies using a dynamic feedback controller. Barakat et al. [6] designed and constructed a two axes sun tracking system with a closed loop control system. This system is used for maximizing the normal incident direct solar radiation on the photovoltaic panels; thus a 20-50% increase in the energetic efficiency can be achieved. Hession and Bonwick [7] reported that using both analog and digital techniques with a sun sensing phototransistors that enabled the sun's position to be resolved to a precision of better than 0.1° .

Ali [8] presented a sun tracking design, whereby the movement of a photovoltaic module was controlled to follow the solar radiation using a PLC unit. A PLC unit was employed to control and monitor the mechanical movement of the photovoltaic module and to collect and store data related to the solar radiation. The photovoltaic tracking system can be employed as a standalone device and it could be connected to a personal computer through the RS232 serial port to monitor the whole process on a computer screen. Roth et al. [3] designed and constructed a sun tracking system operates automatically, guided by a closed loop servo system and a pyrliometer.

Soters [9] described a tracking system which can be used with single-axis solar concentrating systems. The position and "status" of the sun are detected by three light-dependent resistors. Alata et al. [10] presented and demonstrated the design and simulation of time controlled step sun tracking systems that include: one axis sun tracking with the tilted aperture equal to the latitude angle, equatorial two axis sun tracking and azimuth/elevation sun tracking. In addition, an estimation of the insulation

incident on a two axis sun tracking system is determined by fuzzy IF-THEN rules. Veerachary and Yadaiah [11] presented an application of the Artificial Neural Network method in a two axis sun tracking system.

It can be seen that all the above systems are either complicated, expensive or contain many components. In the present work, a real time two axes, hybrid stepper motors driven prototype sun tracker is designed, constructed and tested. The control unit includes a low cost microcontroller compared to the digital signal processors and PLC control unit and provides a large number of input/output pins for controlling the hybrid stepper motors and the LCD screen. Also, the internal memory size and the processing power are high making it the most suitable device for solving solar energy equations in real time. This sun tracker is seen to be simpler and much cheaper than the above PLC, microprocessor and electro-optical controlled systems.

The hybrid stepper motor is used in the present work and offers numerous advantages reported by Delmar [12] as:

- **Stable operation:** can drive a wide range of fractional and inertial loads.
- **Inexpensive plug and play:** easy to setup and used in a system.
- **High torque at low speed:** can drive many loads without gearing.
- **Safe at overload:** the hybrid stepper motor cannot be damaged by mechanical overload.
- **Full torque at standstill:** if the windings are energized.
- **Precise positioning:** motors have an accuracy ranging from 3 to 5% of the step and this error is not cumulative from one step to the next.
- **Very reliable:** since there is no contact brushes in the motor. Therefore, the life of the motor is simply dependant on the life of the bearing.
- **Provides open loop control:** since it responds to digital input pulses, making the motor simpler and less costly to control.

THE SYSTEM MODELING

The two axes sun tracker movement is decided by the relationship between both the solar altitude angle (α) around E-W horizontal axis, and the solar azimuth angle (a) around a vertical axis. The solar altitude angle (α) can be calculated from Duffie and Beckman [13],

$$\sin \alpha = \cos L \cos \delta \cos h + \sin L \sin \delta \quad (1)$$

Where, h is the solar hour angle given by,

$$h = (12 - t) \times 15^\circ \quad (2)$$

t is the local time, hr

L is the latitude angle = 31.04083° N

δ is the solar declination angle which is defined by,

$$\delta = 23.5 \sin \left[\frac{360}{365} (N + 284) \right] \quad (3)$$

Where, N is the day number starting from January first.

The solar azimuth angle (a) is given by Braun and Mitchell [14] as,

$$a = C_1 C_2 (a') + 90 C_3 (1 - C_1 C_2) \quad (4)$$

Where,

$$a' = \sin^{-1} \left[\frac{\sin h \cos \delta}{\cos \alpha} \right] \quad (5)$$

and, C_1, C_2, C_3 Regression constants given by,

$$C_1 = 1 \quad \text{if } \text{abs}(h) < h_{ew} \quad = -1 \text{ Otherwise}$$

$$C_2 = 1 \quad \text{if } L(L-\delta) > 0 \quad = -1 \text{ Otherwise}$$

$$C_3 = 1 \quad \text{if } h > 0 \quad = -1 \text{ Otherwise}$$

$$\cos(h_{ew}) = \frac{\tan \delta}{\tan L} \quad (6)$$

At sunrise hour, the sun starts to move up until 12 noon and then move down to sunset hour angle (h_s) that is given by Duffie and Beckman [13] as,

$$h_s = \cos^{-1} (-\tan L \tan \delta) \quad (7)$$

Where, h_s is the sunset hour angle.

The sunrise hour can be obtained from the symmetry of the day around the noon.

Equations from (1) to (7) are solved by the MATLAB software with 0.01 hour time step from sunrise to sunset hour. The input data to the computer program are the date (day/month/year) and the latitude angle. The output is the solar altitude and azimuth angles at any day of the year.

EXPERIMENTAL SETUP AND PROCEDURE

The experimental setup consists of a vertical axis, 12 mm diameter and 30 cm length fixed from the lower end to a hybrid stepper motor 1 that rotates in the horizontal plane. From the upper end, the axis is fixed to a hybrid stepper motor 2 that rotates in the vertical plane. A hard plastic plate 7 x 7 cm with a number of concentric circles, 2 mm apart, is fixed at one side of the hybrid stepper motor 2 as shown in Fig. 1. An aluminum pointer 1.5 mm diameter and 20.5 cm length is fixed perpendicular to the centre of the plate circles center.

The two hybrid stepper motors have 1.8° per step and are powered via a control circuit. The microcontroller provides a half stepping mode (0.9° per step) for programming the movement of the two motors as reported by Takashi Kenjo [15]. The required electric current and voltage for the control circuit are supplied by an external power supply. The electronic components in the circuit are cooled with an air cooling fan. The circuit, power supply and the fan are fixed on a wooden plate with four screw legs for horizontal adjustment as shown in the same figure. The shadow length can be measured by the concentric circles shown also in Fig. 1. A photograph of the experimental setup is shown in Fig. 2.

Figure 3 shows a block diagram of the control circuit where the basic component is the microcontroller type PIC18F452 from Microchip Company. This microcontroller has been chosen, since it provides a large number of input/output pins (40 pins) for

controlling the hybrid stepper motors and the LCD screen. Also, the internal memory size (32 KB program memory and 1.5 KB data memory) and the processing power are high making it the most suitable device for solving solar energy equations in real time. Moreover, it is readily available in the market with a low cost compared to the digital signal processors and the PLC controller. The hybrid stepper motor interface circuits which consist of high power transistors are used as electronic switches to provide the necessary current and voltage to drive the hybrid stepper motors as reported by Padmaraja and Sandip [16]. These transistors are controlled by the small control signals coming from the microcontroller as shown in the same figure.

The real time clock (DS1307 from Dallas Semiconductor company) is used to provide the microcontroller with time and date which are used by the control program to solve equations from (1) to (7). The 3.3 V battery is used to keep the current time and date in case of power failure. The control buttons are used to adjust, controlling and reset the control circuit and the real time clock with the help of the LCD screen. Also, the LCD screen shows motors angle versus current time and date. The hybrid stepper motors specifications are shown in Table (1) and a photograph of the two hybrid stepper motors is shown in Fig.4.

The experimental work is carried out on the roof of the Thermal engineering laboratory, Mechanical power department, Faculty of Engineering, Mansoura University, latitude 31.04083° N and longitude 31.4861° E. The experiments are conducted in October, 2009. The experimental setup is fixed in the correct direction and the readings of the LCD screen and the length of the pointer shadow are recorded about half an hour intervals.

Before starting of an experiment, the plate is adjusted horizontally by the help of the four screw legs and to the south direction by a compass. The motors start to move towards their correct positions by a step 0.9° . At the correct position, the pointer is directed to the

sun position, which means that the plate is exactly perpendicular to the beam solar radiation with a zero incident angle. At this moment, the shadow length of the pointer is zero. If there is any deviation, it can be measured by the shadow length on the plate. The actual (measured) incident angle is obtained from,

$$\text{Incident angle} = \tan^{-1} \left(\frac{\text{Shadow length}}{\text{Pointer length}} \right) \quad (8)$$

RESULTS AND DISCUSSION

Equations from (1) to (7) are solved by the MATLAB software. Theoretical results for three days of the year representing summer solstice 21 June, winter solstice 21 December and equinox 21 March/September are shown in Fig. 5. Three graphs represent the solar altitude angle for the three days and the other three graphs represent the solar azimuth angles. The maximum value of the solar altitude angle is at 12 noon. While, the solar azimuth angle is negative in the morning, zero at 12 noon and positive in the afternoon hours. The theoretical incident angle is equal to zero all the time of the day.

Figures 6, 7 and 8 show the experimental results for the days 24, 25 and 27/10/2009 respectively. In these figures, continuous lines represent the theoretical results obtained from the MATLAB software. The experimental results for the incident angle are calculated from the shadow and pointer lengths as given in equation (8). The data are taken in the three days, each half an hour, from about 8.30 hr to 15.30 and 16.00 respectively. It is clear that the experimental results are very close to the theoretical results.

The results show that this sun tracker is suitable for the solar photovoltaic panel used for water pumping from wells, solar power generation and the dish type solar concentrators. Hybrid stepper motors with their advantages and the control system are suitable for the above applications. The altitude and azimuth angles obtained from the LCD screen is exactly coincides with that

obtained from the MATLAB software. This is obvious since the same equations are used in the microcontroller.

CONCLUSIONS

In the present study, a prototype two axes sun tracking system (heliostat) is designed, constructed and tested. This sun tracker is a real time controlled and driven by two hybrid stepper motors with a 0.9° step for each motor. Hybrid stepper motors with their advantages and the control system are suitable for these sun trackers. The control unit uses a low cost microcontroller compared to the other controllers. This microcontroller (PIC18F452 from Microchip Company) provides a large number of input/output pins for controlling the stepper motors and the LCD screen. Moreover, the internal memory size and the processing power are high making it the most suitable device for solving the solar energy equations in real time. This sun tracker is seen to be suitable for the photovoltaic panel used for solar pumping and power generation and the dish type solar concentrators. Results have shown that this sun tracker has a good accuracy for tracking the sun, and that the measured data are very close to that calculated from the MATLAB software. This sun tracker is also seen to be reliable, inexpensive and simpler than the previous systems with PLC, microprocessor and electro-optical controlled systems.

NOMENCLATURE

a	Solar azimuth angle,
C_1, C_2, C_3	Regression constants
h	Solar hour angle,
h_s	Sunset hour angle,
L	Latitude angle of the place (31.04083° N for Mansoura, Egypt)
N	The day number starting from January first
t	Local time (hr)

Greek symbols

α	Solar altitude angle,
δ	Solar declination angle.

REFERENCES

- [1] Poulek V. and Libra M. A., "Very simple solar tracker for space and terrestrial applications", *Solar Energy and Material Solar Cells*, 60 (2000), 99-103.
- [2] Abdallah S, and Salem N., "Two axes sun tracking system with PLC control", *Energy Conversion and Management*, 45 (2004), 1931-1939.
- [3] Roth P, Georgiev A, and Boudinov H. "Design and construction of a system for sun-tracking", *Renewable Energy*, 2004, 29 (3): 393-402.
- [4] Clifford M. J. and Eastwood D., "Design of a novel passive solar tracker", *Solar Energy*, 2004, 77(3): 269-80.
- [5] Rubio F. R., Ortega M.G., Gordillo F. and Lopez-Martinez M., "Application of new control strategy for sun tracking", *Energy Conversion and Management*, 48 (2007), 2174-2184.
- [6] Barakat B, Rahab H, Mohmedi B. and Nait N., "Design of a tracking system to be used with photovoltaic panels", *Proceedings of the fourth Jordanian international mechanical engineering conference JIMEC*, 2001, p. 471-88.
- [7] Hession PJ, and Bonwick W.J., "Experience with a sun tracker system", *Solar Energy*, 1984, 32: 3-11.
- [8] Ali M., "Efficiency improvements of photo-voltaic panels using a Sun-tracking system", *Applied Energy*, 79 (2004) 345-354.
- [9] Soteirs A. K., "Design and construction of a one-axis sun tracking system", *Solar Energy* Vol. 57, No. 6, pp. 465-469, 1996.
- [10] Alata M, Al-Nimr M.A. and Y. Qaroush, "Developing a multipurpose sun tracking system using fuzzy control", *Energy Conversion and Management*, 46 (2005), 1229-1245
- [11] Veerachary M. and Yadaiah N., "ANN Based peak power tracking for PV supplied DC motors", *Solar Energy*, 2000, Vol. 69, No. 4, pp. 343-350.
- [12] Delmar, "Modern control technology: component and systems ", McGraw-HILL Company, Second Edition, 2005.
- [13] Duffie J. A. and Beckman W. A., "Solar engineering of thermal processes", New York John Wiley and Sons Inc, 1991.
- [14] Braun J. E. and Mitchell J. C., "Solar geometry for fixed and tracking surfaces", *Solar Energy*, (1983), 31, 439.
- [15] Takashi Kenjo, "Stepping motors and their microprocessor control", Oxford University Press, 1984.
- [16] Padmaraja Y. and Sandip C., "Stepper motor microstepping with PIC18C452", Microchip Technology Inc., Application note AN822, 2002.

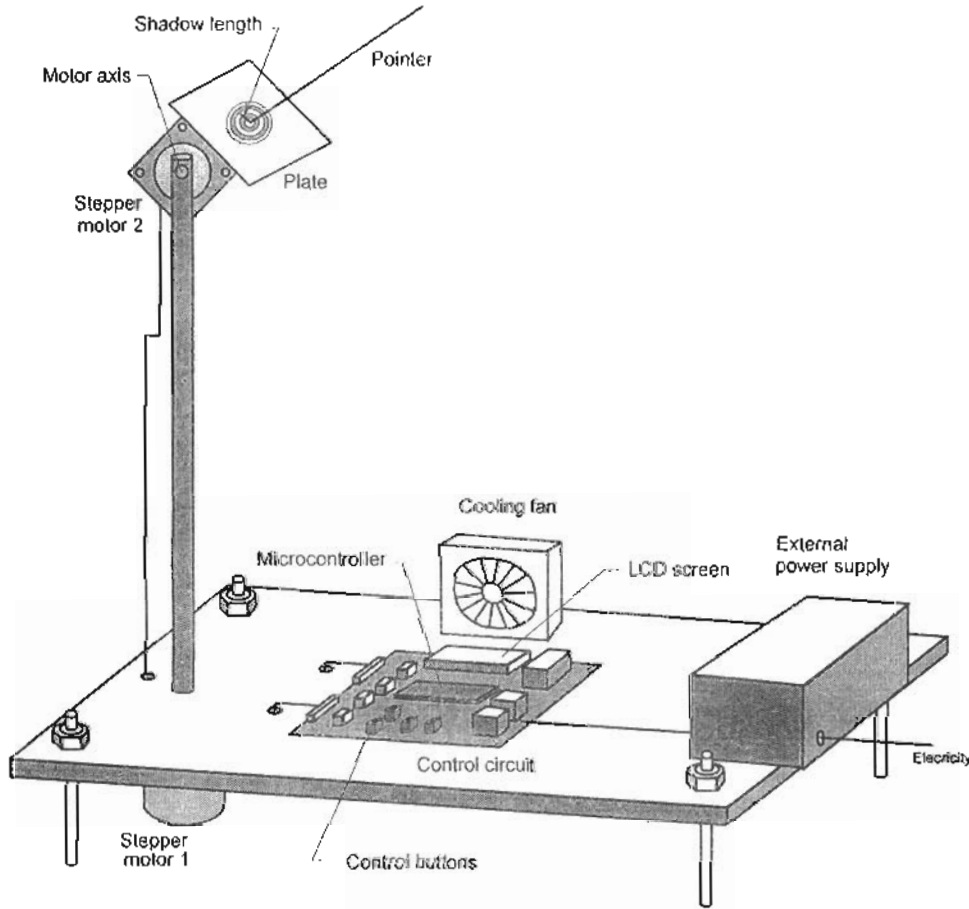

Fig. 1. The experimental setup.

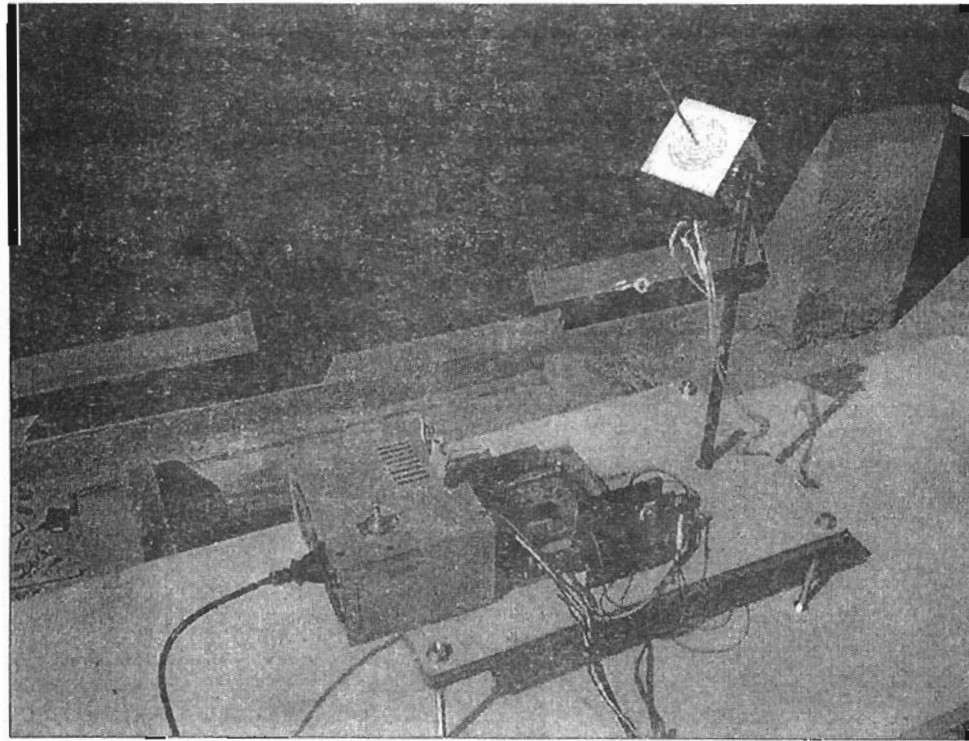

Fig. 2. A photograph of the experimental setup.

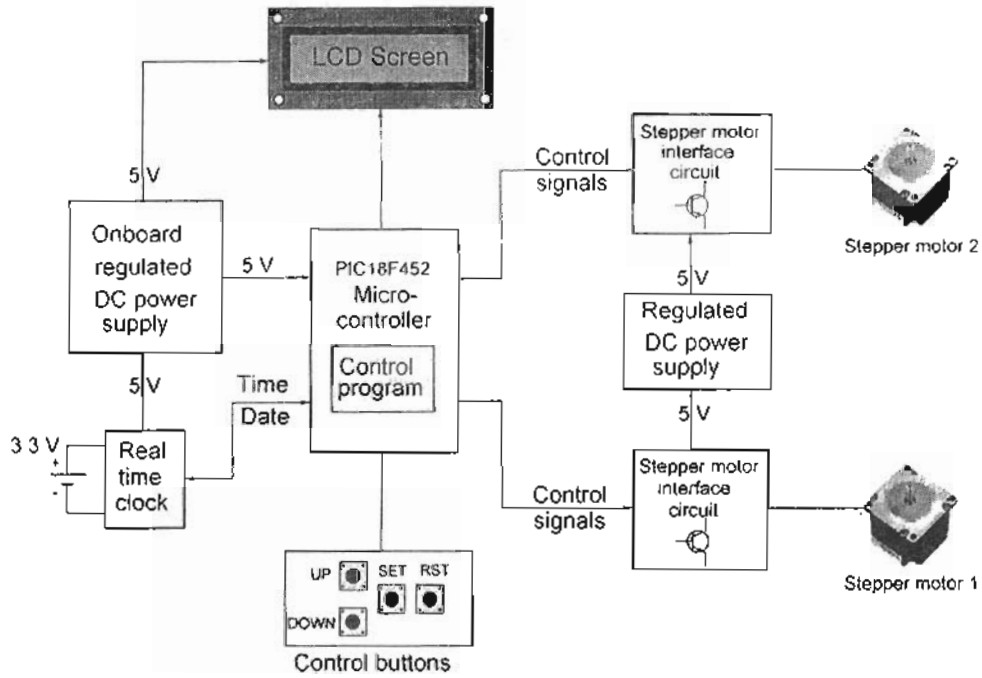
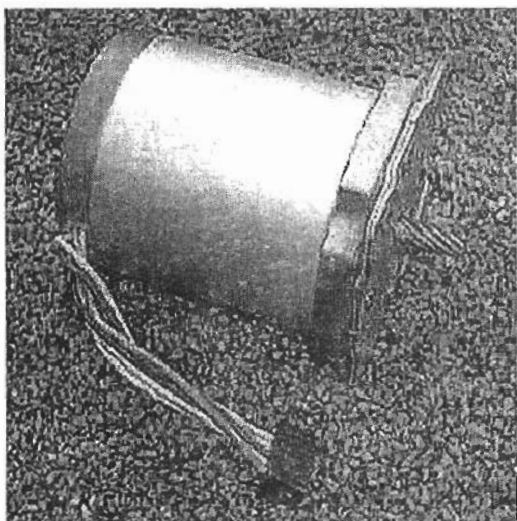

Fig. 3. Block diagram of the control circuit.

Table (1) Specifications of the hybrid stepper motors.

Specifications	Motor 1	Motor 2
Model	KP56QM2-001	PK266-03A
Step angle, Degree	1.8	1.8
Rated voltage, VDC	7.3	3.2
Holding torque, N.m	0.716	1.17
Rated voltage, VDC/phase	5.2	3.2
Connection type	Bipolar (Series)	Bipolar (Series)
Current per phase, A/Phase	1.4	2.1



Hybrid stepper motor (1)

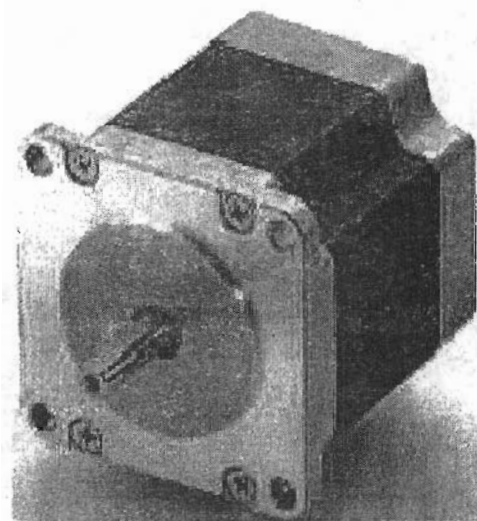

Hybrid stepper motor (2)

Fig. 4. A photograph for the hybrid stepper motors.

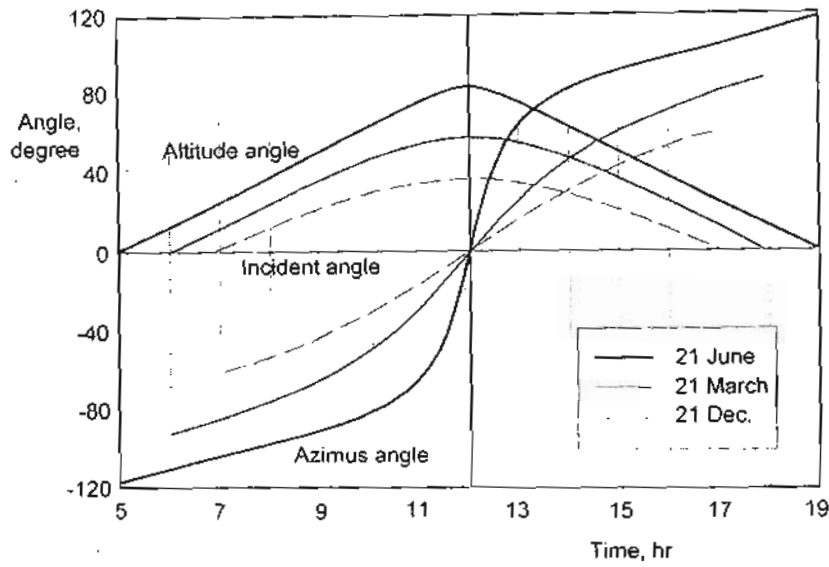

Fig. 5. Theoretical altitude and azimuth angles.

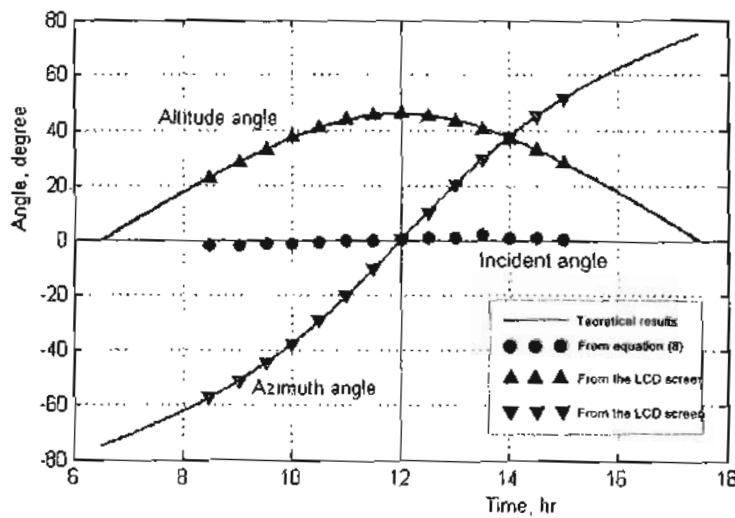

Fig. 6. Theoretical and experimental results for 24/10/2009.

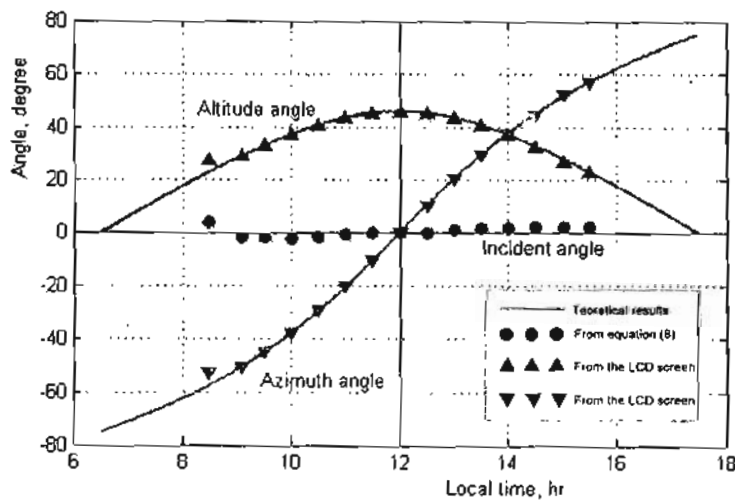

Fig. 7. Theoretical and experimental results for 25/10/2009.

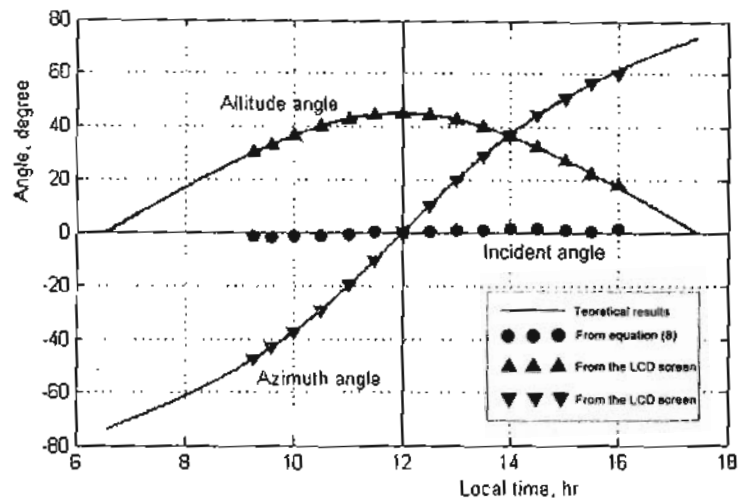

Fig. 8. Theoretical and experimental results for 27/10/2009.