

9-26-2020

Recurrent Neural Networks Based Fault Detection for Synchronous Generator Stator Windings Protection.

A. Helal

Electrical Engineering and Control Department., Faculty of Engineering., Arab Academy for Science and Technology., Alex. Egypt.

H. El Dessouki

Electrical Engineering and Control Department., Faculty of Engineering., Arab Academy for Science and Technology., Alex. Egypt.

A. Hatata

Electrical Engineering Department., Faculty of Engineering., El-Mansoura University., Mansoura., Egypt.

Magdi El-Saadawi

Professor of Electrical Engineering Department., Faculty of Engineering., El-Mansoura University., Mansoura., Egypt., m_saadawi@mans.edu.eg

Mohamed Abd El-Moneim Tantawy

Professor of Electrical Engineering Department., Faculty of Engineering., Mansoura University., Mansoura., Egypt.

Follow this and additional works at: <https://mej.researchcommons.org/home>

Recommended Citation

Helal, A.; El Dessouki, H.; Hatata, A.; El-Saadawi, Magdi; and Tantawy, Mohamed Abd El-Moneim (2020) "Recurrent Neural Networks Based Fault Detection for Synchronous Generator Stator Windings Protection.," *Mansoura Engineering Journal*: Vol. 38 : Iss. 1 , Article 6.
Available at: <https://doi.org/10.21608/bfemu.2020.115397>

This Original Study is brought to you for free and open access by Mansoura Engineering Journal. It has been accepted for inclusion in Mansoura Engineering Journal by an authorized editor of Mansoura Engineering Journal. For more information, please contact mej@mans.edu.eg.

Recurrent Neural Networks Based Fault Detection for Synchronous Generator Stator Windings Protection

تطبيق الشبكات العصبية ذات التغذية الخلفية في حماية ملفات العضو الثابت للمولد التزامني

A. Helal, H. El Dessouki

Dept. of Elec. Engineering and Control,
Faculty of Engineering,
Arab Academy for Science and Technology,
Alex. Egypt.

A. Hatata , M. El Sasdawi, M. Tantawy

Dept. of Elec. Engineering,
Faculty of Engineering,
Mansoura University,
Egypt.

ملخص البحث:

يقدم البحث طريقة مقترحة لحماية المولد التزامني من الاعطال التي تحدث في ملفات العضو الثابت. حيث يعتمد نظام الحماية المقترح للمولد على الشبكات العصبية ذات التغذية الخلفية. تم تصميم وتدريب شبكتين عصبيتين، الاولى تقوم باكتشاف الاعطال التي تحدث في ملفات العضو الثابت والشبكة الثانية تقوم بتحديد نوع العطل ويتم ذلك عن طريق استخدام موجات التيار ثلاثية الوجة الداخلة والخارجة من الملفات والتي تم الحصول عليها من محاكاة انواع مختلفة من الاعطال التي تحدث في ملفات العضو الثابت عند اماكن وازمنة مختلفة وكذا عند مقاومة اعطال ذات قيم مقاومة مختلفة. وقد اثبتت النتائج دقة واستقرار النظام المقترح وكذلك سهولة استخدامه.

Abstract:--

This paper presents a proposed approach for fault detection and faulty phase(s) identification for synchronous generator protection based on artificial neural networks. In order to perform this approach; the protection system is subdivided into different neural network modules for fault detection and classification. The proposed approach uses Recurrent Neural Network (RNN) to detect and classify the synchronous generator internal faults. The RNN uses the three-phase current measurements from both sides of the synchronous generator stator winding as its input data. RNN was trained using various sets of data available from the simulation results of the selected synchronous model under different fault scenarios (fault type, fault location, fault resistance and fault inception angle). Simulation results of the proposed RNN based synchronous generator stator winding protection provide a great performance; in terms of accuracy, speed and reliability.

Keywords: Synchronous generator, Differential protection, Recurrent neural network, Fault detection, Fault classification.

1. Introduction

Protection of synchronous generators is an essential part of the overall power system

protection strategy. The internal faults of the stator winding of synchronous generator need to be identified and

classified rapidly and correctly. The most common method used for generator protection utilized the overcurrent percentage differential relay as the primary protection.

In the last few decades, numerical protection or digital protection was introduced to improve the protection schemes. Several protection techniques [1-8] have been introduced to provide protection against unbalanced fault conditions. A protection technique uses the double frequency current in the field windings and the direction of negative sequence power flow at the generator's terminal for detecting and discrimination of asymmetrical faults [1]. Another digital technique for detecting faults in the stator windings utilizes positive and negative sequence models of synchronous machine, in addition to voltage and current measured at the generator terminal [2]. Power based protection algorithms have been introduced in [3-5]. The first algorithm [3, 4] was introduced to provide protection for non utility generation units against islanding, while the second power-based algorithm was introduced for detecting pole-slipping conditions using three-phase power measurements taken at the generator's terminal and the equal area criterion [5].

Recently various artificial intelligent (AI) techniques are introduced to power

system protection. Among various AI techniques, the Artificial Neural Networks (ANN) have become most frequently used for solving numerous complex electric power system problems. A fault detection and classification problem in the synchronous machine can be treated as a pattern classification problem, and hence ANNs can be used to solve this kind of problem. The most common NN structures used for these applications are the feedforward neural network FFNN and the recurrent neural network RNN. Figure 1 shows the architecture of a feedforward neural network FFNN while figure 2 shows the architecture of the recurrent neural network RNN [6].

Multilayers FFNN based differential protection schemes for generator stator windings was introduced in [7,8]. Ref. [7] uses samples taken from the line-side, neutral-end and field currents of the generator, while [8] uses the difference and average of the currents entering and leaving the generator windings.

The FFNN architectures of figure 1, and algorithms are not well suited for patterns that vary over time. The temporal pattern recognition technique involves processing of patterns which evolve over time. Recurrent networks have feedback connections from neurons in one layer to neurons in a previous layer. The Elman

RNN of figure 2, was proposed to determine the fault direction on transmission lines [9, 10]. In ref. [11] transmission line fault location model based on an Elman recurrent network has been presented for balanced and unbalanced short circuit faults.

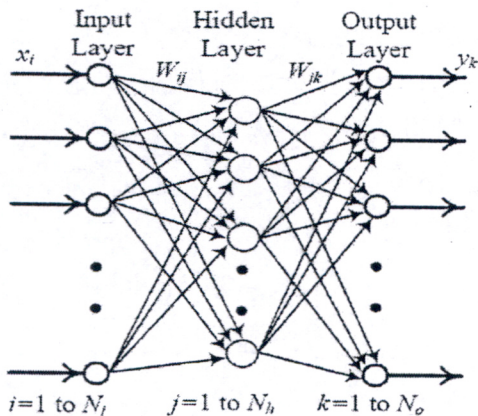

Fig. 1. Feedforward neural network [6]

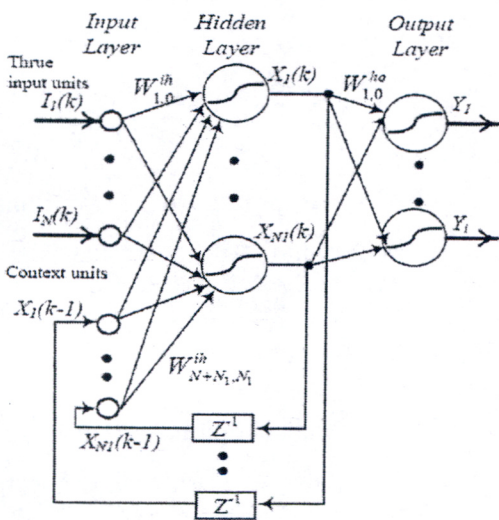

Fig.2 Recurrent neural network [6]

In this paper a RNN is proposed to detect and classify the internal faults on stator windings of synchronous generator. The proposed neural network uses instantaneous values of the three-phase

currents on both sides of stator windings of the synchronous generator to make the decision. The RNN-based algorithm is tested to evaluate the performance of the proposed method in terms of accuracy, robustness and speed. Details of the design procedure and the results of performance studies with the proposed RNN are given and analyzed in this paper.

2. Power system model

The data required for training and testing neural networks are developed using MATLAB / SIMULINK environment. These data should contain necessary information to generalize the problem. A suitable synchronous generator model is required to characterize the different operating and fault conditions. The fault conditions include fault type, location, and resistance and inception angle. In a previous work [12] the authors have developed a dynamic model to simulate generator states (internal fault, external fault, normal states). Three-phase sample power system was simulated and the input/output pair patterns were generated. The developed model will be used in this paper to represent the synchronous generator.

The tested power system consists of three-phase synchronous generator connected to an infinite bus through a

transmission line with the details given in [12]. The measured devices are located at the two ends of the generator. The one line diagram of the modeled power system is shown in Fig.3.

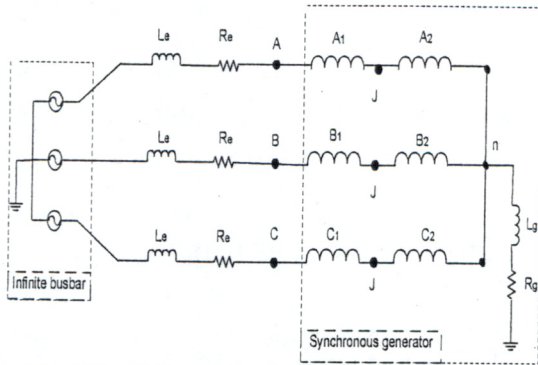

Fig.3 Single line diagram of the modeled power system

3. Recurrent neural network

The ANNs are statistical modeling tools that have a wide range of applications, including time series prediction. Neural networks with hidden units are universal approximators, which theoretically mean that they are capable of learning an arbitrarily accurate approximation to any unknown function. Their complexity is increased at a rate approximately proportional to the size of the training data. Neural networks can be applied to time series modeling without assuming a priori function forms of models [13].

The simplest way to include temporal information into a multilayer feedforward network is by using different time-lagged input variables. For example, for a target series $s(t)$, series $\{s(t-1), s(t-2), \dots, s(t-\tau)\}$

can be used as input variables. Selecting proper time lags and an informative set of input variables is critical to the solution of any time series prediction problems.

For a neural network to be dynamic, it must be given memory. There are two ways to accomplish this requirement. The technique uses time delays. The Time Delay Neural Networks (TDNNs) are multilayer feed forward neural networks. They do not have feedback connections between units. TDNNs provide simple forms of dynamics by buffering lagged input variables at the input layer and/or lagged hidden unit outputs at the hidden layer. The Finite Impulse Response (FIR) network is a feed forward network whose static connection weights between units are replaced by an FIR linear filter that can be modeled with tapped delay lines. The standard back-propagation algorithm is used for training. An alternative is to use the temporal back-propagation learning [14-15].

The second technique is the recurrent networks which have feedback connections from neurons in one layer to neurons in a previous layer. A typical recurrent network has concepts bound to the nodes whose output values feed back as inputs to the network. So the next state of a network depends not only on the connection weights and the currently presented input signals

but also on the previous states of the network. The network leaves a trace of its behavior; the network keeps a memory of its previous states. Depending on the architecture of the feedback connections, there are two general models of recurrent networks: (1) partially recurrent, and (2) fully recurrent.

The back-propagation-through-time algorithm for training a recurrent network is an extension of the standard back-propagation algorithm. It may be derived by unfolding the temporal operation of the network into a layered feedforward network, the topology of which grows by one layer at every time step.

The RNN has some advantages over FNN such as faster convergence, more accurate mapping ability, etc., but it is difficult to apply the gradient-descent method to update the neural network weights in RNN [16].

4. Generation of training data

The simulated cases are divided into three groups. The first is the training group and its patterns are selected randomly and normally distributed in order to make ANN to generalize and prevent skew learning. The second group is used to validate the ANN during the training process and the last one is the test group. Training set consists of 3400 pattern representing different cases of the

generator states which can be classified as:

- The normal operation state represented by three-phase balanced operation at different loads and power factors and has 800 pattern.
- External fault state represented by different types of external faults at various locations along the T.L and has 600 pattern.
- Internal faults state represented by various types of internal faults at different percentages of the stator winding and has 2000 pattern.

5. Proposed protection algorithm using RNN

The first stage of the proposed RNN protection algorithm is the input processing. The input data is collected by measuring the three-phase currents at the two ends of the stator winding. This stage consists of two steps: filtering and normalizing the input data.

- **Filtering:** The current signals are corrupted by high frequency transients, which may not be suitable for the learning of the proposed algorithm. The six current signals are filtered using band pass filter with cutoff frequency 80 Hz to attenuate the D.C and high frequency transient components.
- **Normalization:** Current samples are linearly normalized to be within the

range [-1, 1]. This is done by using the command "mapminmax" in neural network toolbox in MATLAB. Normalizing the input patterns have shown many advantages on speeding up training process, preventing the neural net from working in saturation, and improving the NN performance [17,18].

To ensure that the network can identify faults in a very short time, the three-phase currents are sampled at a rate of 20 samples per a cycle. This sampling rate is commonly used in digital relays [10]. Fig. 4 shows the schematic diagram of proposed protection algorithm. The current signals from the power system are obtained through current transformers. Then these currents are sampled at sampling frequency 1kHz. The selected samples are entered to the fault detector neural network and if the output becomes one, then the sampled data flow to the fault classification neural network and classify the fault type.

6. RNN fault detector

6.1 RNN input and output selection

Long data window enables protective algorithms to get more information and in turn resulting in stable performance. On the other hand, long data window leads to slow decisions. So, after analyzing the simulation results and having acceptable

RNN performance, a short length data window of 4 samples is selected. This data window will be sufficient for detecting all fault types. Therefore, it should have 24 inputs. Hence, the network's input consists of:

$$\begin{aligned}
 & i_{an}(n)T, \quad i_{an}(n-1)T, \quad i_{an}(n-2)T, \quad i_{an}(n-3)T, \\
 & i_{bn}(n)T, \quad i_{bn}(n-1)T, \quad i_{bn}(n-2)T, \quad i_{bn}(n-3)T, \\
 & i_{cn}(n)T, \quad i_{cn}(n-1)T, \quad i_{cn}(n-2)T, \quad i_{cn}(n-3)T, \\
 & i_{aT}(n)T, \quad i_{aT}(n-1)T, \quad i_{aT}(n-2)T, \quad i_{aT}(n-3)T, \\
 & i_{bT}(n)T, \quad i_{bT}(n-1)T, \quad i_{bT}(n-2)T, \quad i_{bT}(n-3)T, \\
 & i_{cT}(n)T, \quad i_{cT}(n-1)T, \quad i_{cT}(n-2)T, \quad i_{cT}(n-3)T.
 \end{aligned}$$

Where $\{ i_{an}(n)T, i_{an}(n-1)T, \dots, i_{cT}(n-3)T \}$ are the time-lagged terminal and neutral side currents.

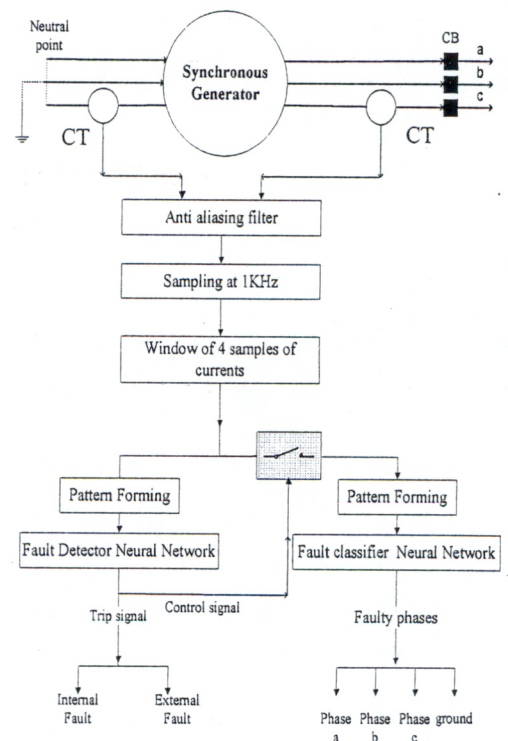

Fig.4 Schematic diagram of proposed protection algorithm

The network needs just one output to differentiate between three states of generator (Normal state, External fault state, and Internal fault state). The network's output should be 1 for the case of internal faults, -1 for the case of external faults and 0 for normal state or no faults.

6.2 RNN structure

Different neural network structures, having different number of neurons in their hidden layers are considered and trained. Training and testing patterns are generated by simulating different types of faults on different locations and phases regions of the simulated generator. The proposed network is a small sized and gives satisfactory results. It consists of 10 neurons in the first hidden layer, 5 neurons in the second hidden layer and one neuron in the output layer. The number of the time delay units is two for the output layer. The RNN structure of the fault detector is (24-10-5(2)-1). Activation function used is a log sigmoid function.

The software used for implementing the algorithm is the MATLAB neural network toolbox.

6.3 Tests and results

After training, the RNN fault detector was tested for many case studies include different fault conditions and different power system data for each type of fault.

Fig.5a illustrates the RNN response for an external fault occurs at the middle of transmission line. The fault is a single phase to ground fault. It occurs at 0.075 sec and the pre fault power flow from generator to infinite bus is $P=1$ p.u. at p.f 0.85 lag. Fig.5a shows the waveform of the three-phase currents at the two ends of the stator winding of the synchronous generator. Where as Fig. 5b depicts the response of the RNN as a function of the time (sec). It can be seen that the network's output has a value of (-1) through 4 samples after the fault occurs.

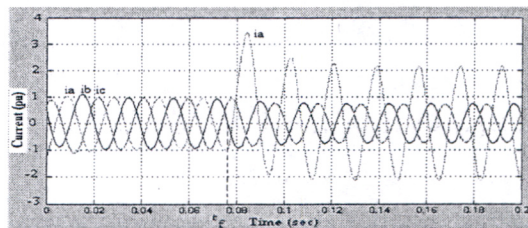

(a) The waveform of the three-phase currents

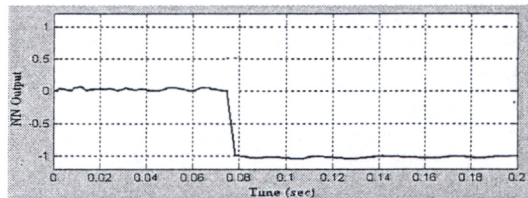

(b) RNN output

Fig. 5 Response of RNN fault detector to an external fault

Fig.6 illustrates the network response for an internal fault. The results are obtained for a single-phase to ground (a-g) fault at 53% of stator winding away from the neutral point, the inception fault time is 0.075 second, the fault resistance is 3Ω , The pre-fault power flow from generator to infinite bus is $P = 1$ p.u. at p.f 0.85 lag.

Fig.6a shows the waveform of three-phase currents. It can be observed that the current of phase a is divided into two currents i_{a1} and i_{a2} . The current i_{a1} has a large value due to short circuit occurs.

Fig. 6b illustrates the response of the network as a function of the time (sec). The network's output is going to the value of (1) through 4 samples after the fault occurs.

The proposed program is implemented for many case studies. The results demonstrate the ability of the fault detector to produce a correct response in all simulation tests.

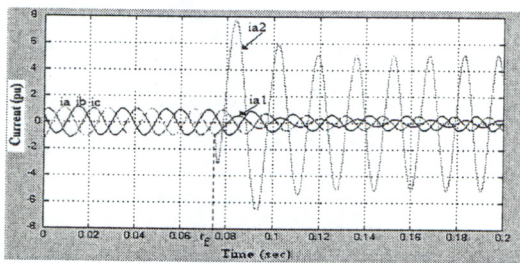

(a) The waveform of the three-phase currents

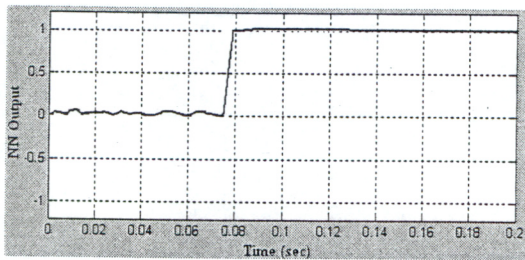

(b) RNN output

Fig.6 Response of RNN detector to an internal fault at 53% of stator winding of synchronous generator

The results show also the stability of the RNN outputs under normal steady state conditions and rapid convergence of the output variables to the expected values

(very closed to 0, 1 and -1) under fault conditions. This clearly confirms the effectiveness of the proposed fault detector. The results reveal that the RNN is able to generalize the situation from the provided patterns, accurately indicates the presence or absence of a fault and can be used for on-line fault detection.

7. RNN fault classifier

The inputs to the fault classifier network are 6 currents, each current is represented by 4 samples, making a total of 24 inputs. The output layer has 4 neurons to represent the faulty phases and the ground.

The generated patterns were normalized the output to be within [0, 1] range. The network outputs were assigned (1) if there is a fault on the corresponding phase and (0) otherwise. Similarly, the network output G had a value of (1) in case of ground faults and (0) for phase faults or normal operating conditions. For example a single phase a to ground has an output equal to [1 0 0 1].

7.1 RNN structure and training

The training patterns are presented to the network in "batch" mode and the mean-square error between targets and actual outputs was calculated. This error was used to update network's parameters (weights and biases) through using the back

propagation through time algorithm. The learning factor μ , was updated in the direction that minimizes the calculated error. At the same time, the error of both validation and testing patterns were calculated and compared with that of the training. The process was repeated to approach the optimal network's parameters.

Various networks were trained to classify the type of faults on stator windings of the synchronous generators. The network, which has 24 inputs, 6 neurons in the hidden layer, 3 neurons in the second hidden layer and 4 neurons in output layer and the number of the time delay units is three for the output layer, showed minimum error and satisfactory results. Different activation functions were tested and the Tan-sigmoid function was found to be the best for this application. The proposed structure (24-6-3(3)-4) results in a small size network. The network had learned the hidden input/output relationship in 80 epochs and minimized the computational burden.

7.2 Simulation and results

The trained RNN network was tested with different independent test patterns. The results indicate that the proposed network is able to classify faults very fast and reliably. The fault classification task is not affected by the

type and fault location, prefault power, fault resistance and fault inception time.

Four different types of faults were tested at different locations on the stator winding away from the neutral point and the network performance is shown in Fig. 7 to Fig. 10. The test condition includes:

1- Phase to phase fault (b-c fault) at 70% of stator winding of synchronous generator away from the neutral point, the inception fault time is 0.075 second, and the pre-fault power flow from generator to infinite bus is $P = 0.9$ p.u. at p.f 0.85 lag. Fig. 7a shows the input current waveforms of the RNN fault classifier and Figures from 7b to 7f illustrate the response of the network as a function of the time (sec).

2- Single-phase to ground fault (a-g fault) at 53% of stator winding of synchronous generator away from the neutral point, the inception fault time is 0.075 second, the fault resistance is 3Ω , and the pre-fault power flow from generator to infinite bus is $P = 0.9$ p.u. at p.f 0.85 lag. Figure.8a shows the input current waveforms of the RNN fault classifier and Figures from 8b to 8f illustrate the response of the network as a function of the time (sec).

3- Double-phase to ground fault (b-c-g fault) at 67% of stator winding of synchronous generator away from the neutral point, the fault resistance is 5Ω ,

the inception fault time is 0.075 second and the pre-fault power flow from generator to infinite bus is $P = 0.6$ p.u. at p.f 0.75 lag. Fig. 9a shows the input current waveforms of the RNN fault classifier and Figures from 9b to 9f illustrate the response of the network as a function of the time (sec).

4- Three-phase to ground fault at 63% of stator winding of synchronous generator away from the neutral point, the inception fault time is 0.075 second and the pre-fault power flow from generator to infinite bus is $P = 0.7$ p.u. at p.f 0.8 lag. Fig. 10a shows the input current waveforms of the RNN fault classifier and Figures from 10b to 10f illustrate the response of the network as a function of the time (sec).

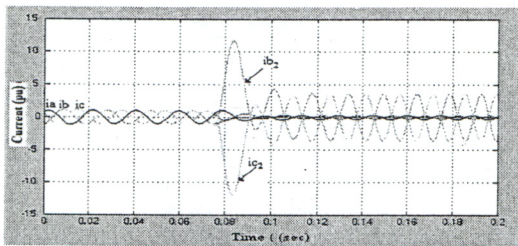

(a) The waveform of the three phase currents

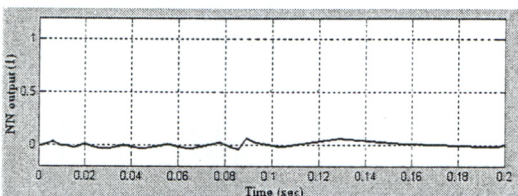

(b) RNN output (1)

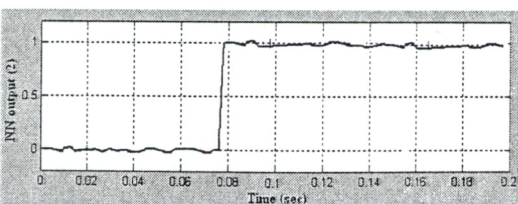

(c) RNN output (2)

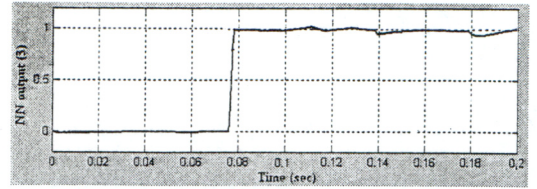

(d) RNN output (3)

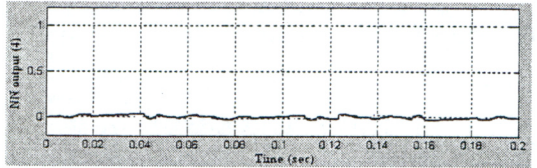

(f) RNN output (4)

Fig.7 Response of RNN fault classifier to internal b-c fault at 70% of stator.

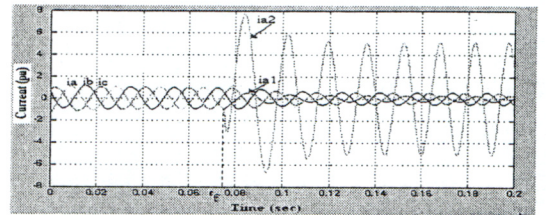

(a) The waveform of the three phase-currents

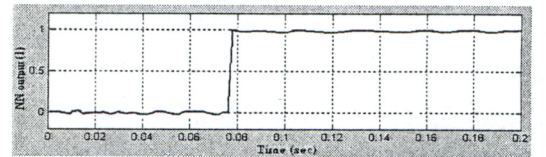

(b) RNN output (1)

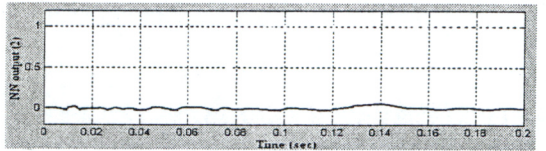

(c) RNN output (2)

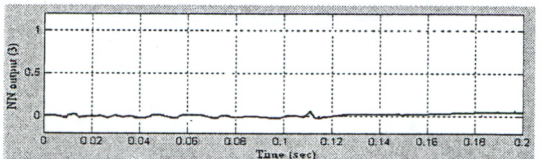

(d) RNN output (3)

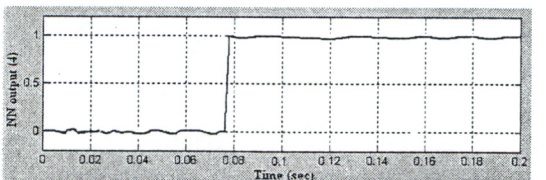

(f) RNN output (4)

Fig.8 Response of RNN fault classifier network to a-g fault at 53% of stator winding.

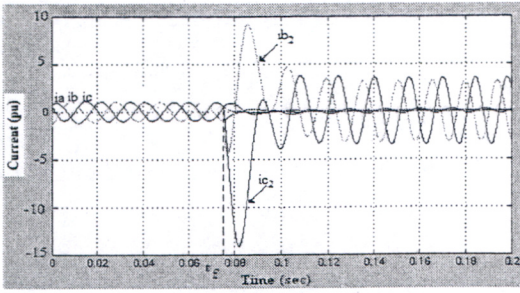

(a) The waveform of the three phase currents

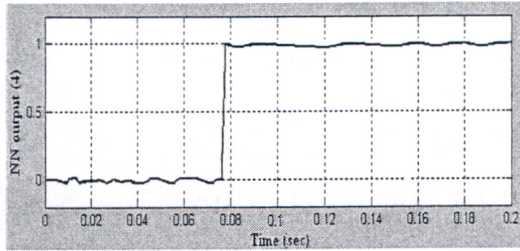

(b) RNN output (1)

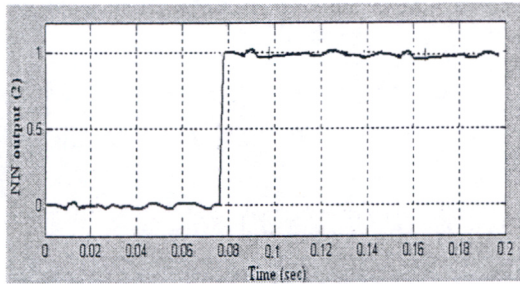

(c) RNN output (2)

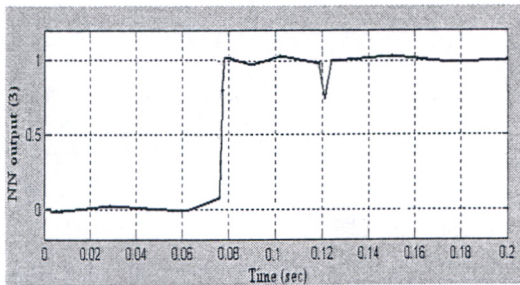

(d) RNN output (3)

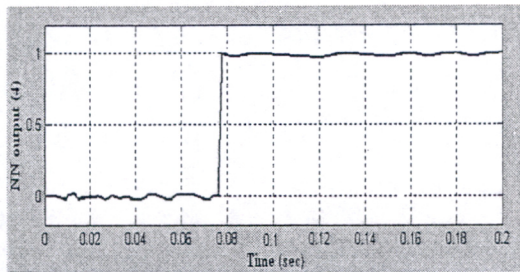

(e) RNN output (4)

Fig.9 Response of RNN fault classifier network for b to c to g fault at 67% of stator winding.

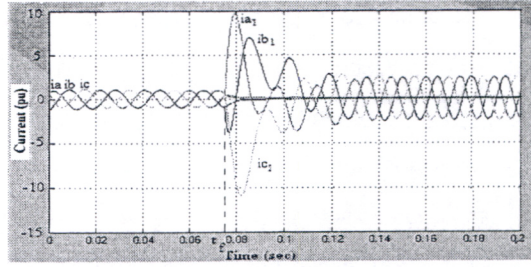

(a) The waveform of the three phase currents

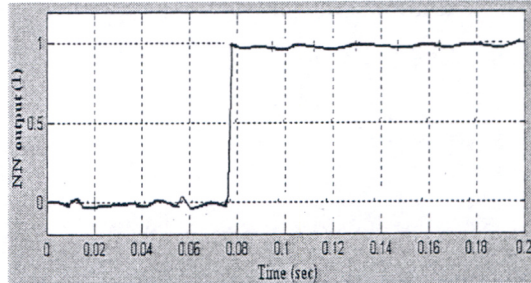

(b) RNN output (1)

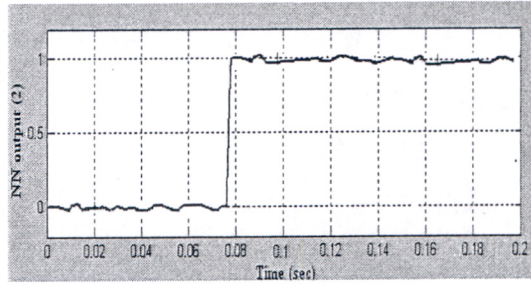

(c) RNN output (2)

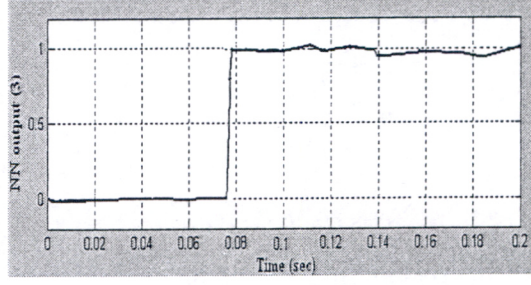

(d) RNN output (3)

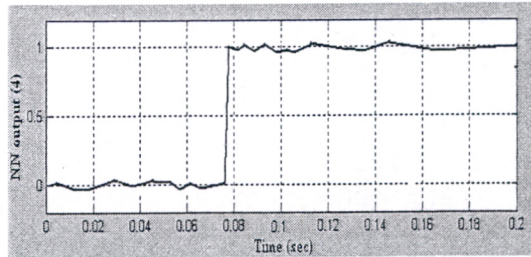

(e) RNN output (4)

Fig.10 Response of RNN fault classifier network to three-phase to ground fault at 63% of stator winding.

The classifier's outputs show that the network correctly and rapidly classifies the different types of faults at different locations even in the presence of fault resistance. The networks succeed in classifying the fault within 4 samples from fault inception. The average time needed to classify the fault types is about 3ms.

8. Conclusion

This paper proposes schemes for detecting and classifying faults in stator winding of synchronous generator using RNN. The detection and classification networks make their decisions based on a quarter cycle information of the 3-phase current at two ends of stator windings. The detection and classification of fault tasks are not affected by the fault type and location, prefault power, fault resistance and fault inception time. Test results show that the proposed modules are highly reliable and very fast in detecting and classifying faults, using the 3-phase current measurements at two ends of stator windings of the synchronous generator. This makes the RNN highly useful candidates to replace conventional modules.

9. References

- [1] P. K. Dash, O. P. Malik, and G. S. Hope, "Fast Generator Protection Against Internal Faults", IEEE Trans. on Power App. Syst., Vol. PAS-96, pp. 1498–1505, Sept./Oct. 1977.
- [2] T. S. Sidhu, B. Sunga, and M. S. Sachdev, "A Digital Technique for Stator Winding Protection of Synchronous Generators", Electric Power System Res., Vol. 36, pp. 45–55, 1996.
- [3] Ö. Usta, "A Power Based Digital Algorithm for The Protection of Embedded Generators", Ph.D. dissertation, Univ. of Bath, Bath, U.K., 1993.
- [4] M. A. Redfern, Ö. Usta, G. Fielding, and E. P. Walker, "Power Based Algorithm to Provide Loss of Grid Protection for Embedded Generation", Proc. Inst. Elect. Eng., pt. C, Vol. 141, pp. 1640–1646, 1994.
- [5] M. A. Redfern and M. J. Checksfield, "A New Pole-Slipping Protection Algorithm for Dispersed Storage and Generation Using the Equal Area Criterion", IEEE Trans. on Power Delivery, Vol. 10, pp. 194–202, Jan. 1995.
- [6] D. A. Asfani, A. K. Muhammad, Syafaruddin, M.H. Purnomo, and T. Hiyama, "Temporary short circuit detection in induction motor winding using combination of wavelet transform and neural network", Expert System with application, Vol. 39, pp.5367–5375, 2012.
- [7] A. I. Megahed and O. P. Malik, "An Artificial Neural Network Based Digital

- Differential Protection For Synchronous Generator Stator Winding Protection", IEEE Trans. on Power Delivery, Vol. 14, pp. 86–93, Jan. 1999.
- [8] A. I. Taalab, H. A. Darwish, and T. A. Kawady, "ANN-based Novel Fault Detector for Generator Stator Winding protection," IEEE Trans. on Power Delivery, Vol. 14, pp. 824–830, July 1999.
- [9] M. Sanaye-Pasand, and O. P. Malik, "Implementation & Laboratory Test Results of an Elman Network-based Transmission Line Directional Relay," IEEE Transactions on Power Delivery, Vol. 14, No. 3, July 1999.
- [10] M. Sanaye-Pasand, and O. P. Malik, "High Speed Transmission System Directional Protection using an Elman Network," IEEE Transactions on Power Delivery, Vol. 13, No. 4, October 1998.
- [11] S. Ekici, S. Yildirim and M. Poyraz, "A transmission line fault locator based on Elman recurrent networks," Applied Soft Computing Vol. 9, p.p 341–347, 2009.
- [12] A. Helal, M. El-Saadawi and A. Y. Hatata, "Modeling of Synchronous Generators for Internal Faults Simulation Using MATLAB /SIMULINK," Mansoura Engineering Journal(MEJ), Vol.35, No.3, September 2010.
- [13] Y. H. HU, J. HWANG, "Neural Network Signal Processing," publishing by CRC Press LLC, 2002.
- [14] Á. L. Orille Fernandez, and N. K. I. Ghonaim, "A Novel Approach Using a FIRANN for Fault Detection and Direction Estimation for High-Voltage Transmission Lines," IEEE Trans. on Power Delivery, Vol. 17, No. 4, October 2002.
- [15] A. L. Orillez and N. Khalil, "A Fast Faulted Phase Detection Relay For High Voltage Transmission Lines Using The FIR Neural Networks," Computers & Industrial Engineering 37 (1999) 395-398.
- [16] A. Karakasoglu, S. I. Sudharsanan, and M. K. Sundareshan, "Identification and decentralized adaptive control using dynamic neural networks with application to robotic manipulators," IEEE Trans. on Neural Networks, Vol.4, pp. 919-930, Nov. 1990.
- [17] T.S. Sidhu, H. Singh and M.S. Sachdev, "Design, implementation and testing of an artificial neural network based fault direction discriminator for protecting transmission lines," IEEE Trans. on Power Delivery, Vol. 10, No. 2, April 1995.
- [18] H. Demuth, M. Beale and M. Hagan, Neural Network Toolbox for use with MATLAB, the Math Works, User's Guide, Version 6.5, 2008.