

10-4-2020

## Enhancement of Active and Reactive Power Flow Control over the Transmission Line Using Unified Power Flow Controller.

Y. Ammar

*Nuclear Researcher center., Atomic Energy Authority., Cairo., Egypt.*

Sahar Kaddah

*Electrical Power Department., Faculty of Engineering., El-Mansoura University., Mansoura., Egypt.*

S. Abd-Elwahab

*Nuclear Researcher Center., Atomic Energy Authority., Cairo., Egypt.*

A. Aly

*Electrical Power Department., Faculty of Engineering., Mansoura University., Mansoura., Egypt.*

Follow this and additional works at: <https://mej.researchcommons.org/home>

---

### Recommended Citation

Ammar, Y.; Kaddah, Sahar; Abd-Elwahab, S.; and Aly, A. (2020) "Enhancement of Active and Reactive Power Flow Control over the Transmission Line Using Unified Power Flow Controller," *Mansoura Engineering Journal*: Vol. 38 : Iss. 2 , Article 2.

Available at: <https://doi.org/10.21608/bfemu.2020.117016>

This Original Study is brought to you for free and open access by Mansoura Engineering Journal. It has been accepted for inclusion in Mansoura Engineering Journal by an authorized editor of Mansoura Engineering Journal. For more information, please contact [mej@mans.edu.eg](mailto:mej@mans.edu.eg).

# Enhancement of Active and Reactive Power Flow Control over the Transmission Line using Unified Power Flow Controller

## تعزيز القدرة الفعّالة وغير الفعّالة عبر خط نقل باستخدام حاكم سريان القدرة الموحد

Y. M. Ammar<sup>\*</sup>, S.S.kaddah<sup>\*\*</sup>, S. A. Abd\_Elwahab<sup>\*</sup> and A.M. Aly<sup>\*\*</sup>

<sup>\*</sup> Nuclear Research Center, Atomic Energy Authority, Cairo, Egypt

<sup>\*\*</sup> Electrical Power Department, Faculty of Engineering, Mansoura University, Egypt

### ملخص

في السنوات الأخيرة، ازداد الطلب على الطاقة الكهربائية بشكل كبير مع محدودية التوسع في عمليتي التوليد والنقل للطاقة الكهربائية نظرا لمحدودية المصادر والضغط البيئية. ونتيجة لذلك فإن بعض خطوط النقل تعمل تحت زيادة الحمل مما يؤثر سلبا على اتزان واستقرار نظم القوى الكهربائية. وتعتبر أنظمة النقل المرنة من المجالات التي شهدت تطورا سريعا وفتحت فرصا جديدة في التحكم في القدرة وتعزيز القدرة الفعّالة وغير الفعّالة فضلا عن رفع مستوى خطوط النقل الجديدة. يعتبر حاكم سريان القدرة الموحد من الجيل الثاني من أنظمة النقل المرنة التي تستخدم في التحكم وتعزيز القدرة الفعّالة وغير الفعّالة عبر خطوط النقل. هذا البحث يشرح التحكم في القدرة الفعّالة وغير الفعّالة من خلال خط نقل عن طريق وضع حاكم سريان القدرة الموحد في شبكة نقل الكهرباء.

**ABSTRACT:** In recent years, power demand has increased substantially while the expansion of power generation and transmission has been severely limited due to limited resources and environmental restrictions. As consequences, some transmission lines are heavily loaded and the system stability becomes a power transfer limiting factor. Flexible alternating current transmission systems (FACTS) technology opens up new opportunities for controlling power and enhancing the usable capacity of present, as well as new and upgraded lines. The Unified Power Flow Controller (UPFC) is a second generation FACTS device which enables independent control of active and reactive power besides improving reliability and quality of the supply. The Unified Power Flow Controller (UPFC) can control active and reactive power flow in transmission line by means of injection controllable series voltage to the transmission line. This paper introduces a new vision of using UPFC that enhances and widens the range of controlling both active and reactive power flow while minimizing the harmonics and keeping the voltage in the specified limit. A model of 110Mvar GTO based UPFC on a 500KV transmission system is simulated and its response is analyzed using MATLAB program.

**Keywords:** FACTS, Matlab/Simulink, Real and Reactive power, UPFC.

## 1. INTRODUCTION

In today's highly complex and interconnected power systems, there is a great need to improve electric power utilization while still maintaining reliability and security. While power flows in some of the transmission lines are well below their normal limits, other lines are overloaded, which has an overall effect on deteriorating voltage profiles and decreasing system stability and security. Because of all that, it becomes more important to control the power flow along the transmission lines to meet the needs of power transfer. On the other hand, the fast development of solid-state technology has introduced a series of power electronic devices that made FACTS a promising pattern of future power systems. The power flow is a function of transmission line impedance, the magnitude of the sending end and receiving end voltages and the phase angle between voltages. By controlling one or a combination of the power flow arrangements, it is possible to control the active, as well as, the reactive power flow in the transmission line. With FACTS technology, such as Static Var Compensator (SVC), Static Synchronous Compensator (STATCOM), Static Synchronous Series Compensator (SSSC) and Unified Power Flow Controller (UPFC) etc., bus voltages, line impedances

and phase angles in the power system can be regulated rapidly and flexibly. These FACTS controllers are based on voltage source converters. Thus, FACTS can facilitate the power flow control, enhance the power transfer capability, decrease the generation cost, and improve the security and stability of the power system [1-2].

A Static Synchronous Series Compensator (SSSC) is a member of FACTS family which is connected in series with a power system. It consists of a solid state voltage source converter which generates a controllable AC voltage at fundamental frequency. When the injected voltage is kept in quadrature with the line current, it can emulate as inductive or capacitive reactance so as to influence the power flow through the transmission line [3-4-5]. While the primary purpose of a SSSC is to control power flow in steady state, it can also improve transient stability of a power system [6]. The UPFC is a member of the FACTS family with very attractive features [7]. The UPFC is able to control, simultaneously or selectively, all the parameters affecting power flow in the transmission line (voltage, impedance, and phase angle) [8]. It is recognized as the most sophisticated power flow controller currently, and probably the most expensive one. The UPFC, which consists of a series and a shunt converter connected by a

common dc link capacitor, can simultaneously perform the function of transmission line real/reactive power flow control in addition to UPFC bus voltage/shunt reactive power control [9-10]. The shunt converter of the UPFC controls the UPFC bus voltage/shunt reactive power and the dc link capacitor voltage. The series converter of the UPFC controls the transmission line real/active power flows by injecting a series voltage of adjustable magnitude and phase angle [11-12-13], on the other hand, the series part known as SSSC can be controlled without restrictions. The phase angle of series voltage can be chosen independently from line current between 0 and  $2\pi$ , and its magnitude is variable between zero and a defined maximum value. The parallel part known as STATCOM injects an almost sinusoidal current of variable magnitude at the point of connection. The main contribution of this paper is to widen the control range of both active and reactive power flow.

## 2. Modeling

### 2.1 UPFC model description

The basic components of the UPFC are two voltage source inverters (VSIs) sharing a common dc storage capacitor, and

connected to the power system through coupling transformers. One VSI is connected to in shunt to the transmission system via a shunt transformer, while the other one is connected in series through a series transformer [14]. A basic UPFC functional scheme is shown in Fig (1).

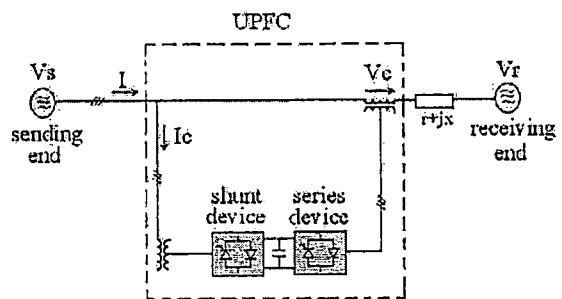

Fig. 1: Basic Functional Scheme of UPFC

Fig (2) shows, the schematic diagram of a UPFC that is used to control the power flow in a 500 kV transmission system. The UPFC located at the left end of the 75-km line L2, between the 500 kV buses B1 and B2, is used to control the active and reactive power flowing through bus B2 while controlling voltage at bus B1. It consists of two 110-MVA, three-level, 48-pulse GTO-based converters, one connected in shunt at bus B1 and the other connected in series between buses B1 and B2. The shunt and series converters can exchange power through a DC bus. The series converter can inject a maximum of 10% of nominal line-to-ground voltage (28.87 kV) in series with line L2 [15].

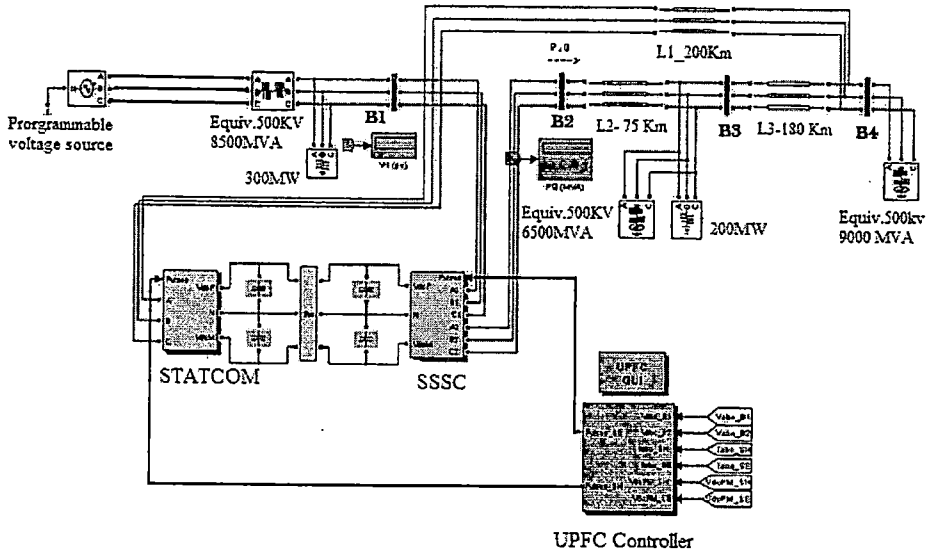

Fig. 2: Schematic Diagram of UPFC

## 2.2 48-pulse three level voltage source GTO inverter

The 48-pulse converter model comprises four identical 12-pulse GTO converters interlinked by four 12-pulse transformers with phase-shifted windings [8]. Fig (3), depicts the schematic diagram of the 48-pulse VS-GTO converter model. It consists of four 3-phase, 3-level inverters and four phase-shifting transformers. The phase shifts produced by the secondary delta connections ( $-30^\circ$ ) and by the primary zig-zag connections ( $+7.5^\circ$  for transformers 1Y and 1D, and  $-7.5^\circ$  for transformers 2Y and 2D) allows to neutralize harmonics up to 45th harmonic, The output voltage have normal harmonics  $n = 48r \pm 1$ , where  $r = 0, 1, 2, \dots$ , i.e.,  $47^{\text{th}}, 49^{\text{th}}, 95^{\text{th}}, 97^{\text{th}}, \dots$ , respectively, with

respect to the fundamental; on the dc side, the lower circulating dc current harmonic content is the  $48^{\text{th}}$ .

The instantaneous values of the phase-to-phase voltage  $V_{ab}(t)$  and the phase-to-neutral voltage  $V_{an}(t)$  of the 48-pulse inverter output voltage is expressed as[9].

$$V_{ab\ 48}(t) = 8 \sum_{m=1}^{\infty} V_{abm} \sin (m\omega t + 18.75^\circ m + 11.25^\circ) \quad (1)$$

$$V_{an\ 48}(t) = \frac{8}{\sqrt{3}} \sum_{m=1}^{\infty} V_{anm} \sin (m\omega t + 18.75^\circ m - 18.75^\circ) \quad (2)$$

Where

$$V_{abm} = \frac{4}{m\pi} V_{DC} \cos \left( \frac{\pi}{6} m \right) \quad (3)$$

$$V_{anm} = \frac{4}{3m\pi} V_{DC} (1 + \cos \left( \frac{\pi}{3} m \right)) \quad (4)$$

$$M = 48r \pm 1, r = 0, 1, 2, \dots$$

$i = 1$ , for positive sequence harmonic

$i = -1$ , for negative sequence harmonics

The voltages  $v_{bc48}$  and  $v_{ca48}$  exhibit a similar pattern except phase shifted by  $120^\circ$  and  $240^\circ$  respectively. Similarly the

phase voltages  $v_{bn48}$  and  $v_{cn48}$  are also phase shifted by  $120^\circ$  and  $240^\circ$  respectively.

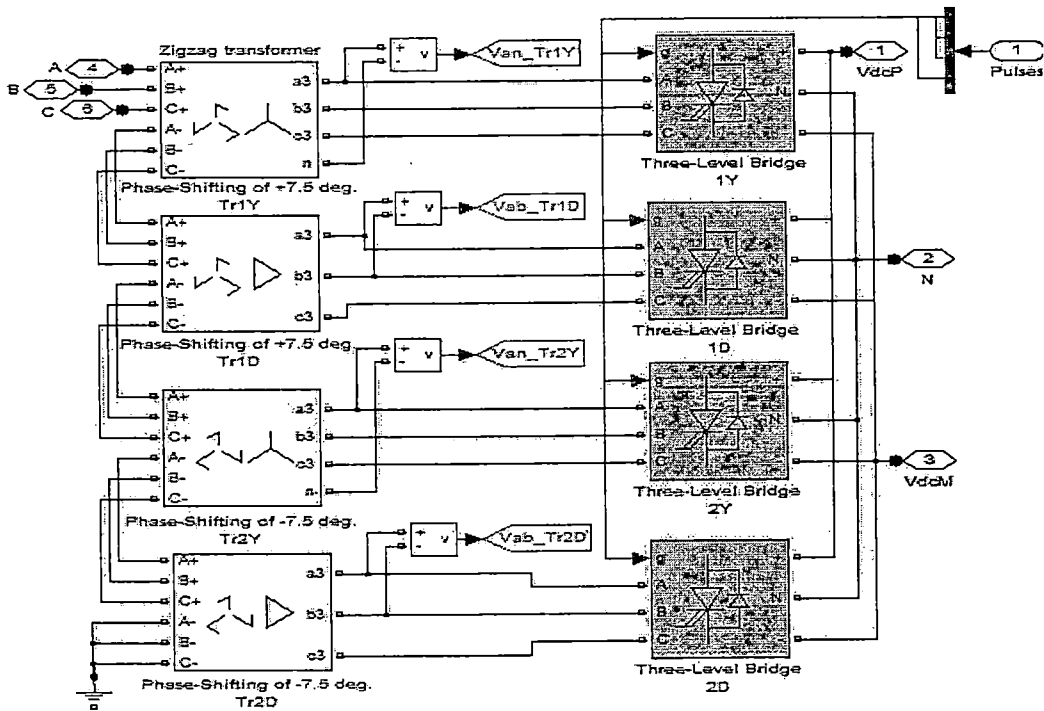

Fig. 3:48-Pulse Inverter GTO's Voltage Source Converter

The voltages  $v_{bc48}$  and  $v_{ca48}$  exhibit a similar pattern except phase shifted by  $120^\circ$  and  $240^\circ$  respectively. Similarly the phase voltages  $v_{bn48}$  and  $v_{cn48}$  are also phase shifted by  $120^\circ$  and  $240^\circ$  respectively. The  $30^\circ$  phase-shift between the Y and D secondary's cancels harmonics  $5+12n$  (5, 17, 29, 41, ...) and  $7+12n$  (7, 19, 31, 43, ...). In addition, the  $15^\circ$  phase shift between the two groups of transformers (1Y and 1D leading by  $7.5^\circ$ , 2Y and 2D lagging by  $+7.5^\circ$ ) allows cancellation of harmonics  $11+24n$  (11, 35, ...) and  $13+24n$  (13, 37, ...). Considering that all  $3n$  the

harmonics are not transmitted by the Y and D secondary's, the first harmonic which are not cancelled by the transformers are 23rd, 25th, 47th and 49th. To minimize the 23rd and 25th we must choose appropriate conduction angle so that we try to find the optimizing conduction angle ( $\sigma = 0^\circ$  to  $180^\circ$ ). The first significant harmonics are therefore the 47th and 49th. This type of inverter generates an almost sinusoidal waveform consisting of 48-steps [10].

### 2.3 STATCOM control system

The model of STATCOM Control System is shown in fig (4). Its task is to

increase or decrease the capacitor DC voltage, so that the generated AC voltage has the correct amplitude for the required reactive power.

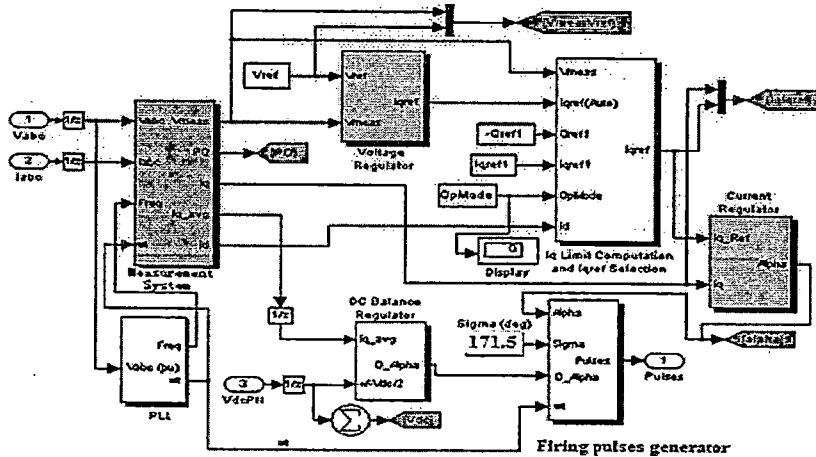

Fig. 4: STATCOM Control System

As the UPFC is expensive device. So, it is obvious to use it as much as possible. In this matter, the control system used in the UPFC is divided into two type's regular control and modified control.

#### A. Regular control

This portion represents the control loops that are generally used

- Phase Locked Loop (PLL)
- Measurement System
- Regular Voltage Regulation
- Firing Pulses Generator

#### B. Modified Control

This portion represents the main contribution of this research. This portion simply uses the following modules:

- Phase Locked Loop (PLL) it synchronizes GTO pulses to the system voltage and provides a reference angle to the measurement system.
- Measurement System it computes the positive sequence components of the STATCOM voltage and current, using phase-to-dq transformation and a running-window averaging and also computes active power and reactive power.
- Modified voltage: it is performed by three PI regulators: from the measured voltage  $V_{meas}$  and two reference voltages  $V_{ref}$  ( $V_{ref1} = 0.9pu$  and  $V_{ref2} = 1.1pu$ , while  $V_{ref} = 1pu$  in regular voltage regulation). The modified

voltage block (outer loop) is shown in fig (5.a) and the regular voltage regulation is shown in Fig (5.b). The outer loop computes the reactive current reference  $I_{qref}$  used by the current regulator block (inner loop) shown in fig (6). The output of the current regulator is the  $\alpha$  angle which is the phase shift of the inverter voltage with respect to the system voltage.

output ( $\omega t$ ) and the current regulator output ( $\alpha$  angle).

The advantage of using this type of control loop is to modify the performance of the active and reactive power flow control and widen the range of them.

### 2.4 SSSC control system

The model of SSSC Control System is shown fig (7). The control system consists of:

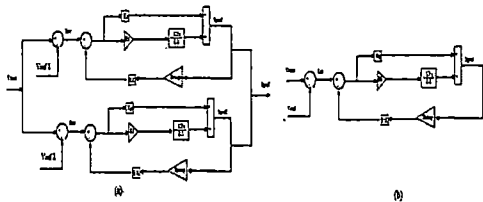

Fig. 5: Schematic Diagram of a) Modified Voltage block, b) Regular voltage

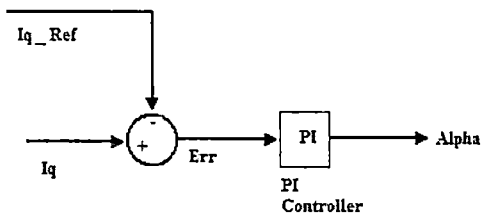

Fig. 6: Schematic Diagram of Current Regulator Block

- Firing Pulses Generator it generates pulses for the four inverters from the PLL

- A phase-locked loop (PLL) which synchronizes on the positive-sequence component of the current  $I$ . The output of the PLL (angle  $\Theta = \omega t$ ) is used to compute the direct-axis and quadrature-axis components of the AC three-phase voltages and currents (labeled as  $V_d$ ,  $V_q$  or  $I_d$ ,  $I_q$  on the diagram).
- Measurement systems measuring the  $q$  components of AC positive-sequence of voltages  $V_1$  and  $V_2$  ( $V_{1q}$  and  $V_{2q}$ ) as well as the DC voltage  $V_{dc}$ .



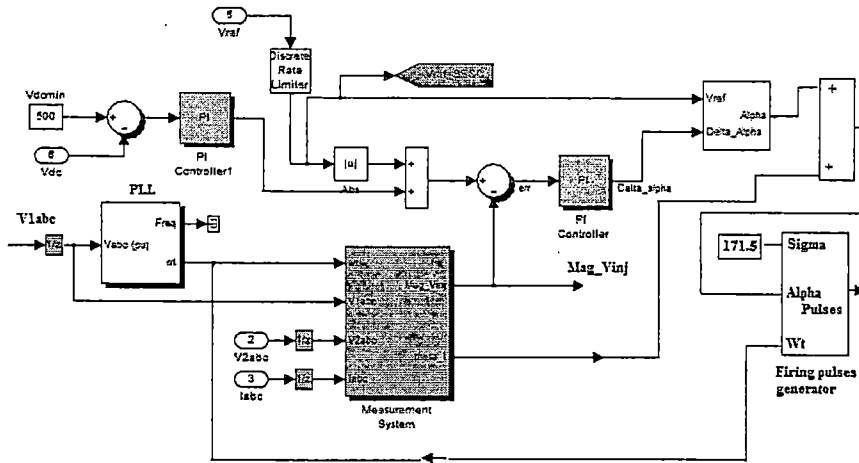

Fig. 7: SSSC Control System

### 3. Simulation Results

The UPFC model has been simulated using MATLAB/Simulink for enhancement of active and reactive power flow control over the Transmission Line while minimizing the harmonics.

#### 3.1 UPFC Conduction Angle Selection

This is an essential step; this step is done through simulations by varying the conduction angle ( $\sigma$ ) from  $10^\circ$  to  $180^\circ$  and the result show in table (1). This table contains the difference sigma angle, total harmonic distortion (THD %) before and after converter. The best point of operation is when:

- The frequency must remain between 49.5 (-1%) and 50.5 (+1%) Hz.

- The total harmonic distortion of voltage must  $THD < 8\%$ ,  $V_3 < 5.0\%$ ,  $V_5 < 6.0\%$ ,  $V_7 < 5.0\%$ .

Based on this rule and from table 1, A conduction angle of  $171.5^\circ$  is chosen as an optimal point.

Table 1: The result for run simulation

Sigma (degree)	$V_{an} \& V_{ab}$ (THD%)	$V_{abc}$ (THD %)	Relative fundamental to 60 HZ (pu)
10	283.39	73.94	0.0848
60	80.31	7.58	0.5015
110	35.15	6.01	0.8217
150	31.93	7.56	0.969
160	36.16	4.53	0.9879
170	41.76	4.35	0.9993
170.5	42.17	4.17	0.997
171	42.36	4.01	1
171.5	42.63	3.89	1
172	42.97	3.82	1.001
172.5	43.28	3.79	1.001

### 3.2 Active and Reactive Power Control using UPFC

#### Case 0: Reference Active and Reactive Power flow Case

To specify the active and reactive power flow reference, the UPFC is disconnected (without control). The normal active power flow  $P = +874\text{MW}$ . So that the reference active power is specified in the simulink. Initially,  $P_{ref} = +8.74 \text{ pu}/100\text{MVA}$  ( $+874 \text{ MW}$ ). The normal reactive power flow,  $Q = -58.8\text{Mvar}$ . So that, the reference reactive power is specified in the simulink. Initially,  $Q_{ref} = -0.588 \text{ pu}/100\text{Mvar}$  ( $-58.8\text{Mvar}$ ).

The controllable region is obtained by keeping the injected voltage to maximum value 10% of nominal line-to-ground voltage (28.87 kV) (0.1pu) and varying its phase angle from  $10^\circ$  to  $360^\circ$ .

#### Case 1: Active and Reactive Power Control

At  $t = 0.2 \text{ sec}$  the reference active power is changed suddenly from 8.74 pu to 10 pu, and at a  $t = 0.4 \text{ sec}$ , the reference reactive power is changed suddenly from -0.588 pu to 0.5pu. Fig (8) shows the reference and controlled active power waveforms. It is shown from this figure that both of these wave forms coincide at the beginning. When the reference active power changes,

the controlled one starts to follow it linearly but it takes about 0.13 sec to do that without any spike.

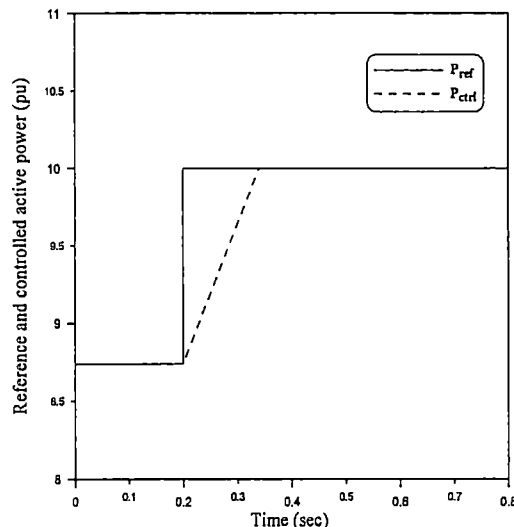

Fig. 8:Reference and Controlled Active Power for Case1

Fig (9) shows the reference and controlled reactive power waveforms. It is shown from this figure that both of these waveforms coincide at the beginning. When the reference reactive power changes, the controlled reactive power is increased linearly to follow it but takes about 0.085sec to do that.

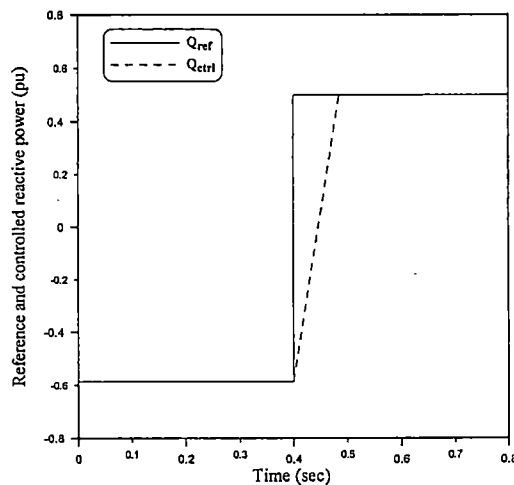

Fig.9: Reference and Controlled Reactive Power (Case1)

Fig (10) shows that the injected voltage is increased linearly from .0126pu at time 0.2 (in which the reference active power increased) to 0.025 pu at time  $t = 0.34$  sec (when controlled active power stabilized). Then remained constant until  $t = 0.4$  sec (when the reference reactive power increased) and starts to increase linearly to  $V_{inj} = 0.033$ pu (when the controlled reactive stabilized) then remained constant. So the injected voltage is changed with both of active power and reactive power.

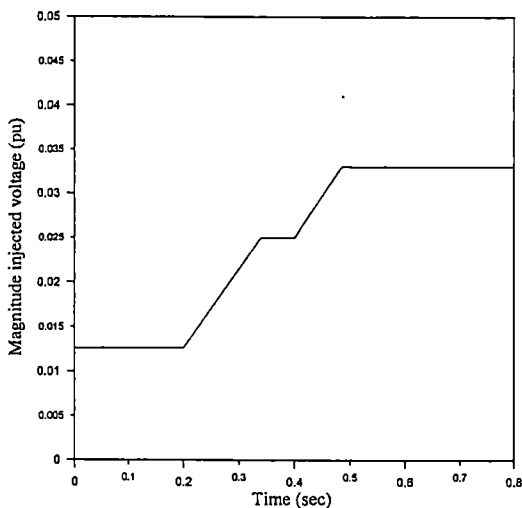

Fig. 10: Magnitude Injected Voltage (Case 1)

Fig (11) shows that, the DC voltage is constant before  $t = 0.4$ sec ( $V_{dc} = 19.3$ KV), after the transient time the DC voltage is raised to 20KV with increasing reactive power. So, the DC voltage changed with reactive power only.

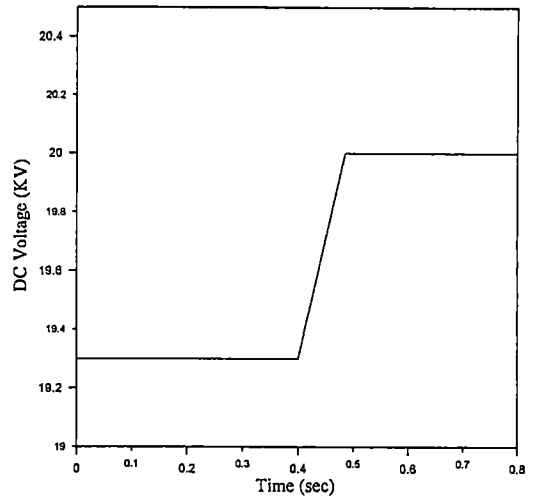

Fig. 11: DC Voltage (Case 1)

### 3.3 Maximum Active Power Control

Searching for the maximum active power flow control using the UPFC with the suggested current control loop, two main cases are performed; one of them tests the increasing of the active power to its upper limit and the other one tests the decreasing of the active power to its lower limit.

#### 3.3.1 Upper Active Power Limit (Case 2)

In this case, the reference active power is changed from normal active power flow (8.74 pu) to a new active power of 13pu at  $t = 0.3$  sec. The active power waveform of the reference and controlled active power are shown in fig (12). Fig (12) shows that, the controlled active power doesn't reach the new reference power of 13pu, but

reaches 12.56pu only and remains constant by activating the UPFC device with the suggested control. This means that, the UPFC maximum final active power value of 12.56 pu. Comparing this upper limit by (12.25pu) the upper limit which mentioned in [15], which means additional increasing in the upper limit by 2.53% is achieved due to adding the suggested control.

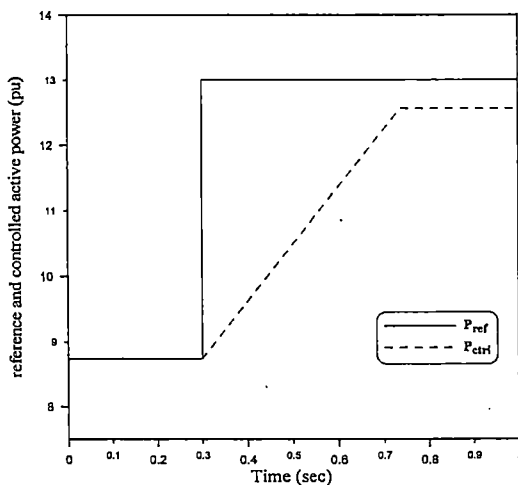

Fig. 12: Reference and controlled active power (case 2)

### 3.3.2 Lower Active Power Limit (Case 3)

In this case, the reference active power is changed from normal active power flow (8.74pu) to a new active power of 5pu at  $t = 0.3$  sec. The reference and controlled power waveform are shown in fig (13). Fig (15) shows that, the controlled active power doesn't reach the new reference power of 5pu, but reaches 5.19pu ( $P= 519$ MW) only and remains constant at this value. This means that, the lower limit

of UPFC is 5.19 pu. If this lower limit is compared by (5.53pu) in [15], concluding that the lower limit is stretched by 6.15%.

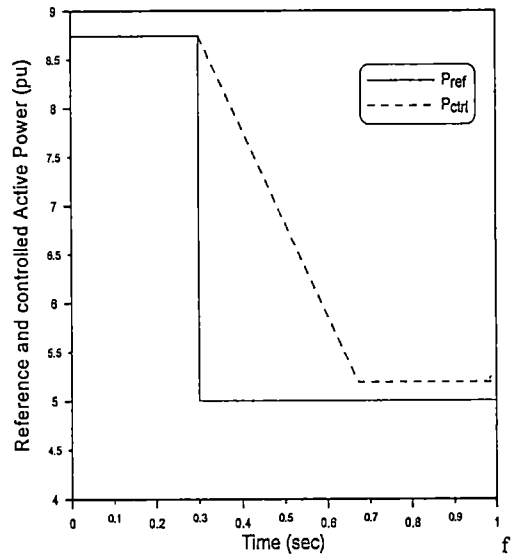

Fig.13: Reference and Controlled Active Power (Case 3)

## 3.4 Maximum Reactive Power Control

Searching for the maximum reactive power control up and down using the UPFC with the suggested control loop, two cases are performed. One of them tests the upper limit and the other one test the lower limit.

### 3.4.1 Upper Reactive Power Limit (Case 4)

In this case, the reference reactive power is increased from 0.588pu to a new reactive power of 3.0pu at  $t = 0.4$  sec. The waveform of the reference and controlled

reactive power are shown in fig (14). Fig (14) shows that, the controlled reactive power reaches only 2.95pu and remains constant. So, the upper limit of the reactive power flow the using UPFC described is 2.95pu, which is the same value mentioned in [15].

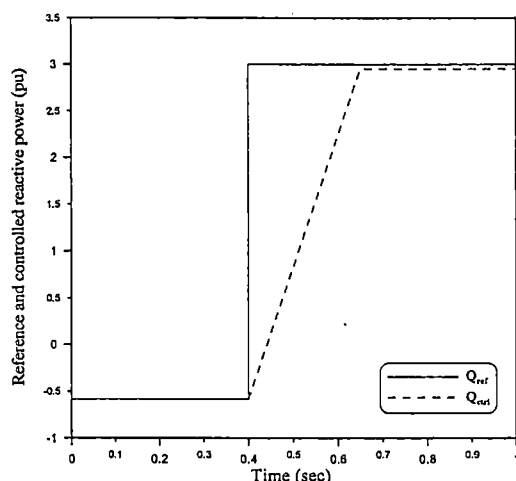

Fig.14: Reference and controlled reactive power (Case 4)

### 3.4.2 Lower Reactive Power Limit (case 5)

In this case the reference reactive power is changed from normal value to anew reactive power equal (-4pu). The waveform of the reference and controlled reactive power are shown in fig (15). Fig (15) shows that, the controlled reactive power doesn't reach to the new reference power (-4pu) but reaches only (-3.77pu) and remains constant at this value. So, the minimum value of reactive power flow in the transmission line by using UPFC described is -377Mvar. Comparing this

lower reactive power limit with (-3.70pu) which mentioned in [15], it is shown that the lower reactive power limit is stretched by 1.9%.

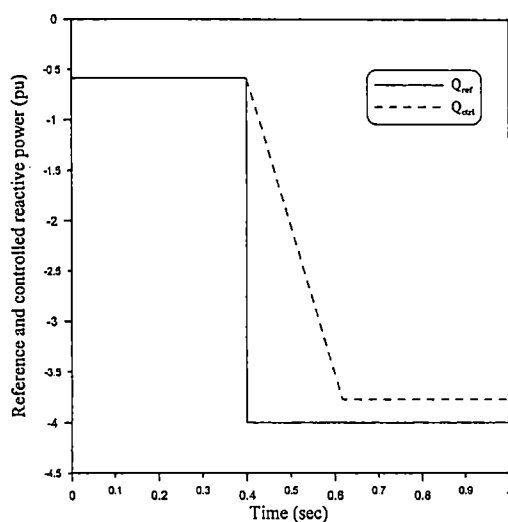

Fig.15: Reference and controlled reactive power (case 5)

## 4. CONCLUSION

Unified Power Flow Controller (UPFC) with 48-Pulse three-level GTO inverter with shifting transformers can neutralize harmonics commendably. The main contribution of this paper is introducing a current control loop for the UPFC. Modeling and simulation of the modified UPFC using Matlab/Simulink has been presented. The simulation results for the 110Mvar GTO based UPFC on a 500KV transmission system is simulated. Prove that the UPFC with the suggested control is stretching the control range of both active/reactive power flows. The upper active power limit is stretched by 2.53%

while, the lower active power limit is stretched by 6.15%. Apparently, the effect of the suggested control on reactive power is smaller compared with the active power as the upper limit doesn't change while the lower limit is stretched by 1.9% only. So, it is concluded that adding this control loop which is almost at no cost enhances the active/reactive power control of the UPFC.

## 5. REFERENCES

- [1] N.G. Hingorani, "High Power Electronics and Flexible AC Transmission System", IEEE Power Eng. REV., 1998
- [2] B.M. Zhang and Q.F. Ding, "The Development of FACTS and its Control", Proc. APSCOM-97, Hong Kong.
- [3] R.M. Mathur and R.K. Varma, "Thyristor-based FACTS Controllers for Electrical Transmission Systems," IEEE Press, 2002 Piscataway.
- [4] K.K. Sen, "SSSC – Static Synchronous Series Compensator: Theory, Modeling and Application", IEEE Trans. on Power Delivery, 1998, 13(1), pp. 241-246.
- [5] L. Gyugyi, 1994, "Dynamic Compensation of AC Transmission Line by Solid State Synchronous Voltage Sources," IEEE Transactions on Power Delivery, 9(22), pp. 904-911.
- [6] Prechanon Kumkratug, Panthep Laohachai, 2007, "Direct Method of Transient Stability Assessment of a Power System with a SSSC," Journal of Computers, 2(8), pp. 77-82.
- [7] I. Musirin, N. Diamah, M. Radzi, M. Murtadha Othman, M. Khayat Idris, and T. Khawa Abdul Rahman, 2008, "Voltage Profile Improvement using Unified Power Flow Controller via Artificial Immune System", WSEAS Trans. on Power Systems, 3(4), pp. 194-204.
- [8] L. Gyugyi, C.D. Schauder, S.I. Williams, T.R. Reitman, D.R. Torgerson, and A. Edris, 1995, "The Unified Power Flow Controller: A new approach to power transmission control", IEEE Trans. on Power Delivery, 10(2), pp. 1085-1097.
- [9] M. Noroozian, L. Angquist, M. Ghandhari, G. Andersson, "Use of UPFC for Optimal Power Flow Control," IEEE Transactions on Power Delivery, 1997 12(4), pp. 1629-1634.
- [10] B.A. Renz, A. Keri, A.S. Mehraben, C. Schauder, E. Stacey, I. Kovalsky, L. Gyugyi, and A. Edris, "AEP Unified Power Flow Controller Performance", IEEE Trans. on Power Delivery, 1999, 14(4), pp. 1374-1381.

E. 14 Y. M. Ammar, S. S. Kaddah, S. A. Abd - Elwahab and A. M. Aly

- [11] I. Papic, P. Zunko, and D. Povh, "Basic Control of Unified Power Flow Controller", IEEE Trans. on Power Systems, 1997, 12(4), pp. 1734-1739.
- [12] P. Kumkratug, M.H. Haque, "Versatile Model of a Unified Power Flow Controller in Simple System," IEEProc. Gener. Transm. & Distrib. 2003,150(2), pp. 155-161.
- [13] L. Gyugui, 1992, "A Unified Power Flow Control Concept of Flexible AC Transmission Systems", IEE Proceedings-C,139(4), pp. 323-331.
- [14] S. Tara Kalyani, G. Tulasiram Das"Simulation of real and reactive power flow control with UPFC connected to a transmission line",Journal of Theoretical and Applied Information Technology , 2008 JATIT.
- [15] N.K.Sharma and P.P.Jagtap,"Modelling and application of Unified Power Flow Controller (UPFC)", Third International Conference on Emerging Trends in Engineering and Technology, 2010 IEEE.