

10-15-2020

Investigation of Electromagnetic Transients in Electric Power Systems.

E. Tantawy

Electrical Engineering Department., Faculty of Engineering., El-Mansoura University., Mansoura., Egypt.

Ebrahim Badran

Electrical Engineering Department., Faculty of Engineering., El-Mansoura university., Mansoura., Egypt., ebadran@hotmail.com

Mansour Abdel Rahman

Electrical Engineering Department., Faculty of Engineering., El-Mansoura University., Mansoura., Egypt.

Follow this and additional works at: <https://mej.researchcommons.org/home>

Recommended Citation

Tantawy, E.; Badran, Ebrahim; and Abdel Rahman, Mansour (2020) "Investigation of Electromagnetic Transients in Electric Power Systems.," *Mansoura Engineering Journal*: Vol. 38 : Iss. 2 , Article 4. Available at: <https://doi.org/10.21608/bfemu.2020.118800>

This Original Study is brought to you for free and open access by Mansoura Engineering Journal. It has been accepted for inclusion in Mansoura Engineering Journal by an authorized editor of Mansoura Engineering Journal. For more information, please contact mej@mans.edu.eg.

INVESTIGATION OF ELECTROMAGNETIC TRANSIENTS IN ELECTRIC POWER SYSTEMS

دراسة ظواهر قطع التيار العابرة في نظم القوى الكهربائية.

E. Tantawy, Ebrahim A. Badran and Mansour H. Abdel Rahman

Electrical Engineering Department, Faculty of Engineering, Mansoura University, Egypt

email : ebadran@hotmail.com

المخلص

يتناول البحث بالدراسة والتحليل موضوع دراسة ظواهر قطع التيار العابرة في نظم القوى الكهربائية المترابطة مع حقول الرياح وهو من الموضوعات الحيوية الهامة في مجال نظم القوى الكهربائية حيث أصبحت الطاقة الكهربائية الناتجة من حقول الرياح تمثل عنصرا هاما في تغذية الأحمال الكهربائية بالشبكات. وتم التركيز على تحليلات ومناقشات لظواهر قطع التيارات العابرة في حالات الكابلات الكهربائية والكابلات البحرية حيث يتم استخدام الكابلات البحرية في حالات حقول الرياح المترابطة مع الشبكات الكهربائية. وقد تم التطبيق على الشبكة الدنمركية بعد تمثيل هذه الشبكة ببرنامج الظواهر العابرة.

Abstract

In this paper the electromagnetic transients in electrical power systems are described, analyzed, and investigated. The cable-based networks are the main concern of this investigation. Several transient phenomena are described theoretically and demonstrated by means of simulations performed both in simple and complex systems. The EMTP-ATP is used for the simulation. Some of the phenomena are very unlikely to occur and have an uncertainty associated with them, while others can be predicted with a high degree of certainty. Some depend only on the cable and equipment directly attached to it, while others depend on the cable and surrounding area.

For all these reasons, one cannot immediately say which phenomena should be prioritized when performing an insulation co-ordination study. The application of the countermeasures depends on the phenomenon that must be minimized. However, some of the countermeasures intensify some phenomena while at the same time minimizing others. The energisation of cables in all its different variants; ideal energisation, energisation in weak grids, and energisation of cables in parallel are discussed. The energisation of a cable in a weak grid poses an interesting challenge, because of the high overvoltages associated to the phenomenon. Another interesting analysis is the one made on the energisation of cables in parallel. The de-energisation of a cable is another transient phenomenon that needs to be investigated.

Introduction

Interest towards using underground cables in power transmission has increased considerably. There are significant differences between cables and overhead lines (OHL). While transients in OHL are often caused by lightning, in cables can be caused by breaker operations [1].

There are a large number of phenomena associated with a cable connection/disconnection that may result in overvoltages, but the type of studies carried out should depend on the cable and network characteristics, as some phenomena are likely to happen only under specific conditions.

The impact of a cable in a power grid **must be assessed for both normal and fault** operations, being typical the performance of insulation co-ordination studies when installing a cable [2].

The simulation of cable energisation is normally always performed as it may result in temporary overvoltage and/or slow-front overvoltages. Examples of phenomena that may occur during cable energisation are:

- Switching overvoltage, of which magnitude and duration are associated with the switching instant and cable length [3 – 6].
- Due to the interaction between a cable and a transformer, resonance overvoltages are also associated with a cable energisation. Energisations of cables are especially dangerous when the transformer inrush current matches the system resonance frequency [5, 6].

- Depending on the reactive power compensation level and the switching instant, the current flowing into the circuit breaker may not have zero crossing for some time after the switching instant, making it impossible to open the circuit breaker without risking to damage it. This phenomenon goes by the name of zero-missing [7].
- The energisation of cables in parallel with an already energised cable may result in high-frequency inrush currents, a phenomenon similar to the energisation of capacitor banks in parallel [2].

Besides the occurrence of unwanted situations associated with the energisation of a cable, there are undesirable phenomena during a cable disconnection. Typically, a cable de-energisation is unlikely to originate any substantial overvoltage, but it may represent a serious risk to the system if a restriking in the circuit breaker occurs.

The consequence of a restriking in hybrid cable-OHL is presented in [8] and [9]. The surge impedance for OHL is typically 300-400 Ω while it is less than 40 Ω for cables. The lower surge impedance may result in the higher time derivative of the transients. This is because the time constant for the voltage across a load like a transformer when hit by a step voltage propagating along a transmission line (cable or OHL), depends proportionally on the surge impedance of the cable and the capacitance of the load.

In some cable lines a shunt reactor is directly connected to the cable, being disconnected together with the cable [10]. For all these reasons, one cannot immediately say which phenomena should be prioritized when performing an insulation co-ordination

study. The application of the countermeasures depends on the phenomenon that must be minimized. However, some of the countermeasures intensify some phenomena while at the same time minimizing others.

The Alternative Transients Program (ATP) is considered to be one of the most widely used universal program system for digital simulation of transient phenomena of electromagnetic as well as electromechanical nature in electric power systems. With this digital program, complex networks and control systems of arbitrary structure can be simulated. ATP has extensive modeling capabilities and additional important features besides the computation of transients [11].

The ATP program predicts variables of interest within electric power networks as functions of time, typically initiated by some disturbances. Basically, trapezoidal rule of integration is used to solve the differential equations of system components in the time domain. Non-zero initial conditions can be determined either automatically by a steady state phasor solution or they can be entered by the user for simpler components.

In this paper the electromagnetic transients in electrical power systems are described, analyzed, and investigated. The cable-based networks are the main concern of this investigation. Several transient phenomena are described theoretically and demonstrated by means of simulations performed both in simple and complex systems. ATP is used for the simulation. Some of the phenomena are very unlikely to occur and have an uncertainty associated with them, while others can be predicted with a high degree of certainty. Some depend only on the cable and equipment directly attached

to it, while others depend on the cable and surrounding area.

The energisation of cables in all its different variants; ideal energisation, energisation in weak grids, and energisation of cables in parallel are discussed. The energisation of a cable in a weak grid poses an interesting challenge, because of the high overvoltages associated to the phenomenon. Another interesting analysis is the one made on the energisation of cables in parallel. The de-energisation of a cable is another transient phenomenon that needs to be investigated.

2. Transients Phenomena

A short description of the different phenomenon associated with the use of cables is provided in this section. Switching overvoltages, zero-missing phenomenon, energisation of cables in parallel, cable and shunt reactor disconnection, and cable de-energisation are discussed. Furthermore, the categorization and the summary are introduced for the phenomena.

2.1 Switching Overvoltage

A cable energisation may originate a transitory overvoltage, whose amplitude depends on the moment in which the cable is connected. If the circuit breaker is closed when the voltage at its terminals is zero, the overvoltage is minimum, ideally zero, but if the connection is made for a peak voltage, the overvoltage is maximum [6].

The reason for this difference is the charging of the cable's capacitance and the energy oscillation between the cable's capacitance and inductance. To better understand this phenomenon it will be

E. Tantawy, Ebrahim A. Badran and Mansour H. Abdel Rahman

explained using a simple LC series circuit shown in Fig. 1a. The resulted voltages and current are illustrated in Fig. 1b.

A cable consists of distributed capacitance, inductance and resistance. Thus, a cable's energisation wave form is initially similar to the energisation of an LC circuit, but with damping due to the resistance.

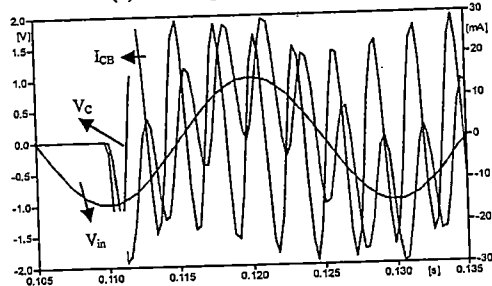
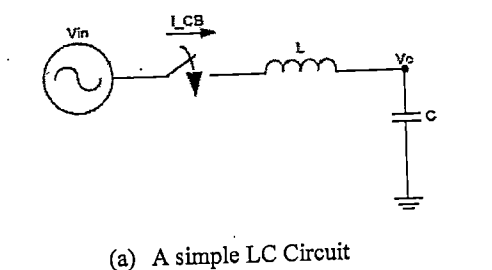

(a) A simple LC Circuit
(b) Voltages and current for circuit in (a)
Fig. 1: Energisation of a simple LC circuit

2.2. Zero-Missing Phenomenon

Zero-missing can occur when compensating for more than 50% of reactive power of a cable using shunt reactors and is characterized by having a current not crossing zero point during several cycles after energizing the cable reactor system, which may be hazardous to the system [2].

When a shunt reactor is energized, both an AC and decaying DC current component appear. The decay of the DC current

component disappears depending on the cable and shunt reactor resistances and its initial value depend on the voltage value of the shunt reactor and the shunt reactor inductance [2]. The circuit shown in Fig. 2a is used to explain the phenomenon. The resulted voltages and current are illustrated in Fig. 2b.

If the reactive power compensation ratio is higher than 50%, the AC current component in the shunt reactor is larger than the AC current component in the CB, and the DC component in the CB may be higher than the AC component. In this situation the current does not cross zero during several cycles, and zero missing phenomenon occurs.

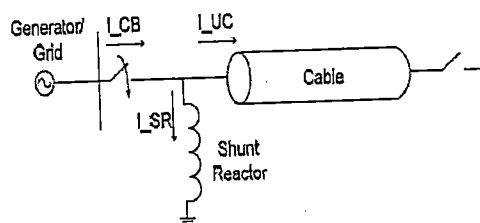

(a) A Cable-Shunt Reactor Circuit

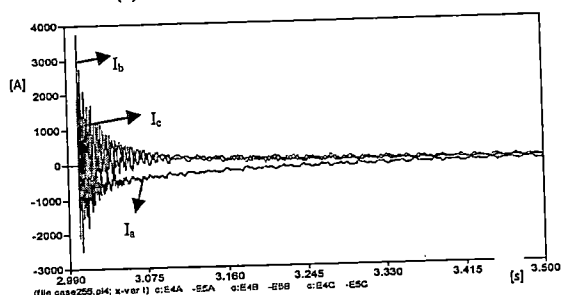

(b) Zero-missing currents for 70% shunt compensation
Fig. 2: Energization of a Cable-Shunt Reactor system

2.3. Energisation Of Cables In Parallel

The energisation of cables in parallel can be regarded as similar to the energisation of capacitor banks in parallel [1]. When energising capacitor banks in parallel, the energisation of the second capacitor bank results in a higher resonance frequency and amplitude of the inrush current when compared with the energisation of the first capacitor bank [5].

Fig. 3a shows an example of the phenomenon. When the circuit breaker in the second cable is closed, the energy stored in the capacitors of the already energised cable is transferred to the capacitors of the cable being energised, as indicated by the arrows.

The amplitude and frequency of the inrush current are influenced by the cable lengths and the short-circuit power behind the busbar, both increasing when the short-circuit power decreases.

Fig. 3b and 3c show the results of the energizing of two cables of equal length in parallel. Fig. 3b shows the current in the first cable to be energised and Fig.3c the currents in both cables during the energisation of the second cable. The magnitude and frequency of the current are both larger for the energisation of the second cable.

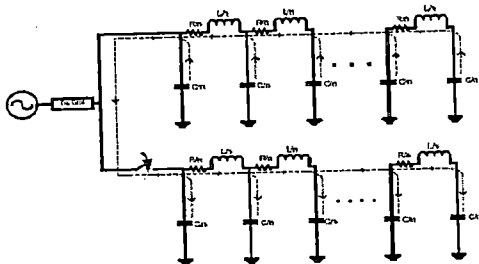

(a) Equivalent circuit for the energisation of cables in parallel

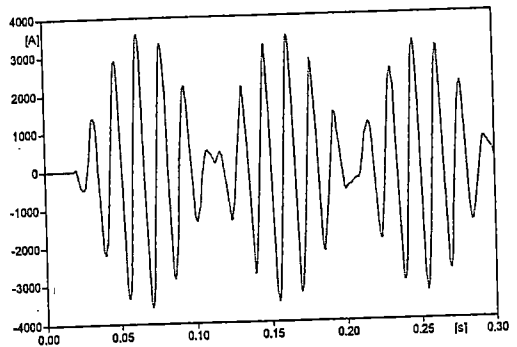

(b) Current in Cable A during the energisation;

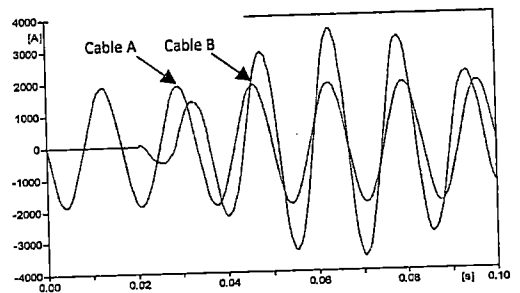

(c) Currents in the sending ends of Cable A and Cable B during the energisation of Cable B

Fig. 3: Energization of Two Parallel Cables

2.4. Cable-Shunt Reactor Disconnection

When a cable is disconnected the energy stored in the cable has to be dissipated, which may take several seconds, because of the low cable resistance and high capacitance. The disconnection of a cable is similar in many ways to the disconnection of a capacitor,

Fig. 4a shows the single-line diagram of the RLC circuit used to simulate a capacitor switch-off. A capacitor's current leads the voltage by approximately 90°. Thus, when a capacitor is disconnected, it is fully charged and has a voltage at its terminals of ± 1 pu. The capacitor's energy is damped through the resistor, and as the

resistor value is usually low when compared with the capacitance, the complete de-energisation of the capacitor can take a long time [5].

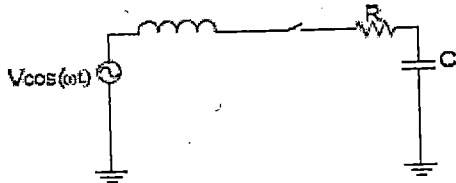

(a) The RLC circuit

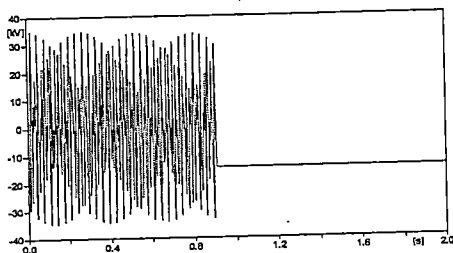

(b) Typical de-energisation of a capacitor charge

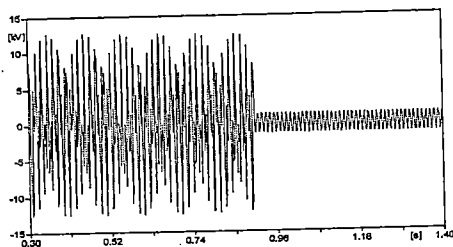

(c) Cable voltage

Fig. 4: Capacitance Switching off

If the cable is connected to a shunt reactor and they are de-energised together, the voltage is no longer a decaying DC component, but a decaying AC component oscillating at resonance frequency, as shown in Fig. 4c. In this situation, no overvoltage is expected, but this is because mutual inductances between the shunt reactor phases were not taken into consideration

2.5. Cable De-energisation – Restrike

The disconnection of HV underground cables may, if unsuccessful, cause a restrike in the circuit breaker, resulting in the correspondently high overvoltages, potentially damaging the cable and nearby equipment.

Due to the high cable capacitance, voltage damping is slow, resulting, in a voltage of approximately 2 pu at the circuit breaker terminals half a cycle after the disconnection. In case of restrike in that instant, it is theoretically possible to attain an overvoltage.

Restrikes can also take place in hybrid cable-OHL lines. During re-energisation of a hybrid line there are reflections and refractions in the cable-OHL junction point, and if the restrike occurs in the cable end CB, the voltage is magnified in the junction point resulting in a larger overvoltage [6].

2.6. Phenomena Categorization

The IEC standards define the overvoltages into four different types [2]:

- Temporary overvoltage (TOV) which are characterized by their amplitude, voltage shape and duration and may have a long duration, up to one minute. These overvoltages can be caused by faults, switching conditions, resonance conditions and non-linearity.
- Slow-Front Overvoltages (SFO) which are characterized by their voltage shape and amplitude, they have a front duration of up to some milliseconds and are oscillatory by nature. These are caused by line energisations and de-energisations, faults, switching of

capacitive/inductive elements or lightning strokes.

- Fast-Front Overvoltages (FFO) which are mainly associated with lightning strokes and are characterized by the standard lightning impulse wave.
- Very-Fast-Front Overvoltages (VFFO) which are associated with GIS switching operations and SF6 circuit-breaker re-ignitions.

3. Analysis of the Transient Phenomena

A real system is used for analysis of transient phenomena. The system is picked from [2] and manipulated for investigation purposes. ATP is used to simulate the studied power systems.

3.1. System Description and Modeling

The system is a 215 MW wind farm. The cable connection consists of two land cable sections with a combined length of 57.7 km and a 42 km submarine cable. To compensate for the reactive power production of the cables an 80 MVAR shunt reactor is installed 2.3 km from the connection point between the land and submarine cable. Additionally two reactors of 40 and 80 MVAR are installed in 150 kV side of the substation. Finally, a 400 MVA autotransformer is used to connect the 150 kV side to the 400 kV transmission grid in the substation. A single line diagram of the system is presented in Fig. 5.

The land cable connection consist of three single phase aluminum conductor cables each having a cross section of 1200 mm² and a rated voltage of 165 kV. Fig. 6 shows the cross-section of the 150 kV land cable and the submarine cable, respectively. Tables 2 to 5 gives the prepared and

manipulated parameters for ATP for system land cable, submarine cable, transformer, and shunt reactor, respectively. The system model in ATP is presented in Fig. 7.

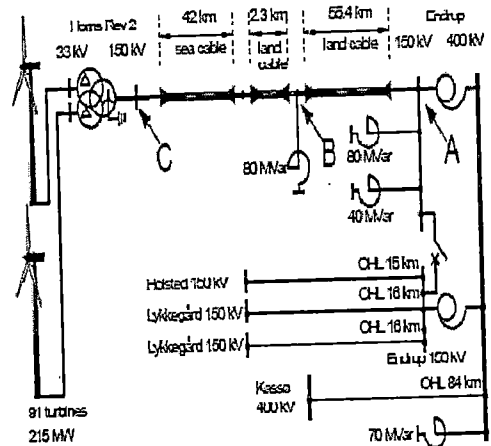

Fig. 5: A single line diagram of the test system

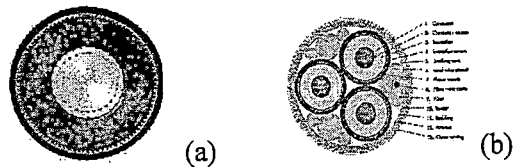

Fig. 6: Cross-section of (a) the 150 kV land cable and (b) the submarine cable

Table 2: Shunt Reactor Self-Impedance (The 80 MVAR /170 kV Shunt Reactor)

	Phase A	Phase B	Phase C
Resistance [Ω]	0.755	0.927	0.551
Inductance [H]	1.144	1.144	1.143

Table 3: Land Cable Parameters

Conductor outer radius	20.75 mm
Insulation outer radius	40.85 mm
Insulation relative permittivity	2.95
Outer insulation relative permittivity	2.3

Table 4: Submarine Cable Parameters

Conductor outer diameter	30.5 mm
Insulation diameter	69.5 mm
Insulation screen thickness	75.5 mm
Longitudinal water barrier thickness	0.6 mm
Phase screen diameter	84.9 mm

Table 5: Transformer Parameters

Power [MVA]	119.44
Voltage [kV]	33/150
Leakage reactance [pu]	0.99487
Air core reactance [pu]	0.42
Time to release flux clipping [s]	0.7

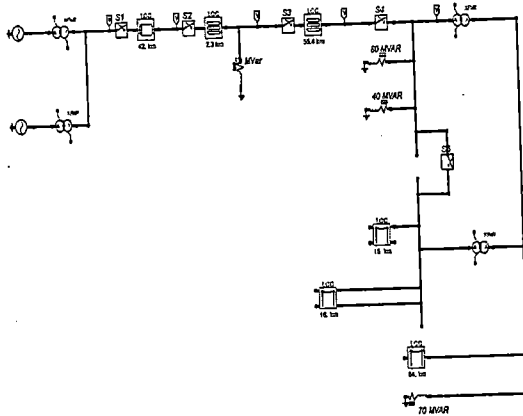
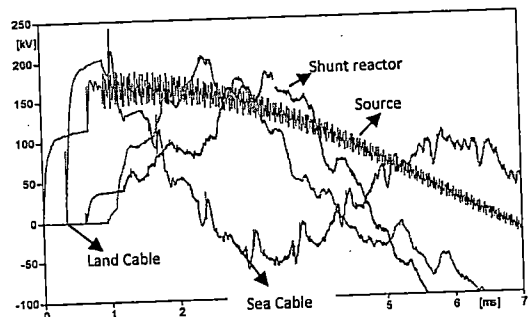

Fig. 7: The System Model in ATP

3.2. Simulation Results

The cable system is firstly energized by closing one of the breakers at point C, B, or A and the transient phenomena is investigated. Fig. 8 illustrates the voltage and current waveforms when the system is energized at point C, i.e. the sending end of the sea cable. From Fig. 8a, it is seen that the transient over voltages are shown at the end of the sea cable, at the 80 MVA shunt reactor, and at the end of the land cable, as expected. The overvoltage is 1.4 pu at the sea cable, 1.17 pu at the shunt reactor, and 1.3 pu at the end of the land cable. Fig. 7b shows the currents. It is clearly seen the DC components and the small shunt reactor current.



(a) Voltage waveforms

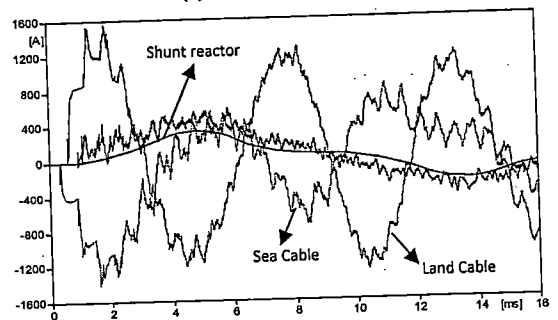

(b) Current waveforms

Fig.8: Energisation the System at Point C

Fig. 9 illustrates the voltage and current waveforms when the system is energized at point of coupling of sea cable and land cable, i.e. the receiving end of the sea cable. It is seen that the transient over voltages are shown at the shunt reactor and at the end of the land cable. The overvoltage is 1.66 pu at the shunt reactor and 1.63 pu at the end of the land cable.

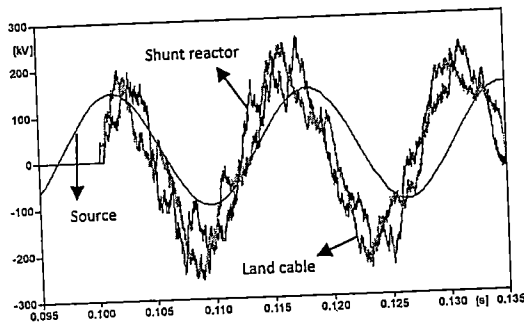

Fig.9: Voltage Waveforms when Energising at Coupling Point of Sea and Land Cables

Fig. 10 illustrates the voltage when the system is energized at point B, i.e. the shunt reactor. It is seen that the transient over voltages are shown at the shunt reactor and at the end of the land cable. The overvoltage is 1.55 pu at the shunt reactor and 1.7 pu at the end of the land cable.

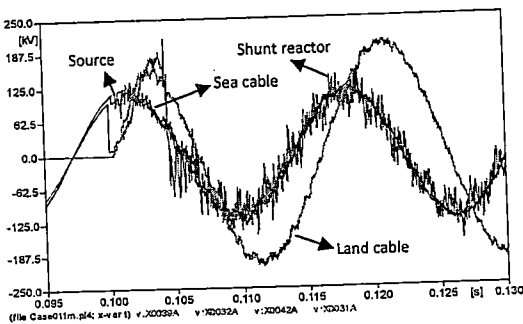

Fig.10: Voltage Waveforms when Energising at Point B

Fig. 11 illustrates the voltage waveforms when the system is energized at point A, i.e. the receiving end of the land cable. It is seen that the transient over voltages are shown at the shunt reactor and at the end of the land cable. The overvoltage is 2.3 pu at the shunt reactor, 2.34 pu at the end of the land cable, and 1.7 pu at the energized system.

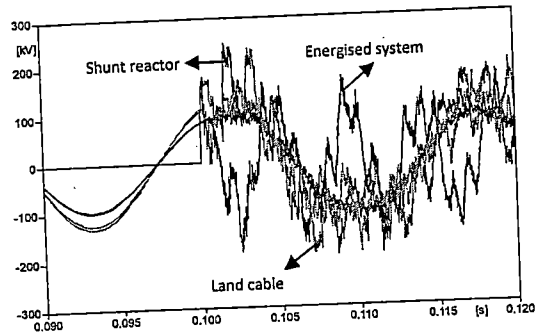

Fig.11: Voltage Waveforms when Energising at Point A.

4. Conclusions

In this paper the electromagnetic transients in electrical power systems are described, analyzed, and investigated. Several transient phenomena are described theoretically and demonstrated by means of simulations performed both in simple and complex systems. The EMTP-ATP is used for the simulation. The cable-based networks are the main concern of this investigation. The energisation of cables in all its different variants; ideal energisation, energisation in weak grids, and energisation of cables in parallel are discussed.

The corresponding risks due to the transient phenomena are introduced through simple separate cases and through a real system. The energisation of the system at

critical points shows that the resulted overvoltages must be undertaken.

The energisation of a cable in a weak grid poses an interesting challenge, because of the high overvoltages associated to the phenomenon. So, the authors propose to extend deeply this investigation in weak grids.

5. References

- [1] F. Faria da Silva, Claus L. Bak, and Per B. Holst, "Energization of Long HVAC Cables in Parallel – Analysis and Estimation Formulas", IEEE Transactions in Power Delivery, 2012.
- [2] F. da Silva, "Analysis and Simulation of Electromagnetic Transients in HVAC Cable Transmission Grids", Ph.D. Thesis, Aalborg University, Denmark, 2011.
- [3] A. I. Ibrahim, H. W. Dommel, "A Knowledge Base for Switching Surge Transients", International Conference on Power Systems Transients (IPST), Canada, Paper No. 50, 2005
- [4] Ivo Uglesic, Sandra Hutter, Miroslav Krepela, Bozidar Filipovic-Grcic, Franc Jakl, "Transients Due to Switching of 400 kV Shunt Reactor", International Conference in Power Systems Transients (IPST), Brazil, Paper No. 045, 2001.
- [5] Alan Greenwood, "Electric Transients in Power Systems, John Wiley & Sons, 1st Edition, 1978
- [6] Lou van der Sluis, "Transients in Power Systems", John Wiley & Sons, 2001
- [7] F. F. da Silva, C. L. Bak, U. S. Gudmundsdottir, W. Wiechowski, M. R. Knardrupgard, "Methods to Minimize Zero-Missing Phenomenon", IEEE Transactions on Power Delivery, Vol. 25, No. 5, October 2010.
- [8] CIGRE Working Group B1.05, "Transient Voltages Affecting Long Cables", 2005
- [9] E. W. Greenfield, W. A. Pullman "Transient Behavior of Short and Long Cables", IEEE Transaction on Power Apparatus and Systems, Vol. PAS-103, No. 11, 1984
- [10] Claus Leth bak, Wojciech Wiechowski, Kim Søgaaard, Søren Damsgaar Mikkelsen, "Analysis and Simulation of Switching Surge Generation When Disconnecting a Combined 400 kV Cable/Overhead Line with Shunt Reactor", International Conference in Power Systems Transients (IPST), France, Paper No. 24, 2007.
- [11] Hans Kr. Høidalen "ATPDraw user manual version 5.6", August 2010.