

7-13-2020

Controlling the Load Power Factor Automatically.

M. Ammar

Electrical Engineering Department., Faculty of Engineering., El-Mansoura University., Mansoura., Egypt.

Saad Eskander

Professor of Electrical Engineering Department., Faculty of Engineering., El-Mansoura University., Mansoura., Egypt.

A. Elmitwally

Electrical Engineering Department., Faculty of Engineering., El-Mansoura University., Mansoura., Egypt.

A. Shahin

Electrical Engineering Department., Faculty of Engineering., El-Mansoura University., Mansoura., Egypt.

Follow this and additional works at: <https://mej.researchcommons.org/home>

Recommended Citation

Ammar, M.; Eskander, Saad; Elmitwally, A.; and Shahin, A. (2020) "Controlling the Load Power Factor Automatically.," *Mansoura Engineering Journal*: Vol. 39 : Iss. 3 , Article 12.

Available at: <https://doi.org/10.21608/bfemu.2020.102727>

This Original Study is brought to you for free and open access by Mansoura Engineering Journal. It has been accepted for inclusion in Mansoura Engineering Journal by an authorized editor of Mansoura Engineering Journal. For more information, please contact mej@mans.edu.eg.

Controlling the Load Power Factor Automatically

التحكم فى معامل قدرة الحمل أوتوماتيكيا

M. Ammar, S. S. Eskander, A. Elmitwally, A. Shahin,

Dept. of Electrical Engineering ,Faculty of Engineering ,Mansoura University

ملخص

إن ترشيد الطاقة و تحقيق مستوى متقدم فى إدارة الأعمال للتطبيقات الحديثة يحتاج لتحسين معامل القدرة أوتوماتيكيا إستخدام تقنية الميكروكنترولر لتحسين معامل القدرة بإستخدام رقائق ADE7763 والتي تحدد قيمة معامل القدرة ومعرفة القيمة المطلوبة للمكثفات التي يجب اضافتها للوصول الى معامل القدرة المستهدف (0.95) على سبيل المثال بالإضافة الى إمكانية المراقبة عن طريق الإنترنت و شبكات المحمول وقد تم تحقيق نتائج مميزة في سرعة عمل النظام وصغر حجم المساحة التي يشغلها.

Abstract

This paper focuses on the design and implementation of the automatic control system based on microcontroller that enhances the load power factor (PF) in real time. The system is designed to detect the load power factor and improve it automatically. The system is composed of a microcontroller which compares between the measured load power factor that is received from the energy metering integrated circuit (ADE7763) and a pre-stored value "PF = 0.95". Based on the calculated difference in power factor, the microcontroller drives the power switches (relays circuit) through an interface circuits to choose the appropriate capacitor bank that is required to improve the power factor. Furthermore, the system is able to send the system power factor data in real time to clients either by a Short Message Service (SMS) through an integrated GSM module or by the World Wide Web (internet) through an Integrated Ethernet Module.

Keywords

Microcontroller, power factor, power switches, GSM, Ethernet.

1.1 Introduction

This paper presents the background information, method, and design to determine the economic feasibility of power factor correction as a method for improving efficiency and reducing losses of the electric utility system. Power factor correction will be analyzed in multi-family dwellings (apartments), single family residences, commercial buildings and industrial buildings. As power factor correction is not a new concept, the proposed system had four objectives; the First objective is to measure the power factor for many loads. This involved creating data bases to simplify handling of the data being collected. Second, is to gain

a better understanding of the reactive loads. This understanding includes the age of the appliances or equipment's discharging the reactive power and the types of installations involved. The Third objective is to correct the power factor in the most cost effective manner to measure the effect of the installation and determine the cost versus benefit of the installations, also to determine the value of capacitors required for improve the system power factor. The Final objective is to monitor and control the system by SMS through GSM module and form web page through Ethernet module. Power Factor is the ratio of the power needed to do the work within customer premises to the total volt-ampere

delivered by the utility. A power factor of 1.0 is ideal (unity). Appliances and machinery within customer premises discharge reactive power, measured in Kilovolt Amperes Reactive (KVAR). More KVAR present on a utility system results in a lower power factor, and higher currents (I) present on the wires.

There are some problems such as, (i) How to detect the power factor for one load and for many load, (ii) How to calculate the suitable value for the capacitor banks that will entered to the system to enhance the system power factor to its pre stored value (0.95), (iii) How to choose the suitable components that implemented to the system, (iv) Compile the code into microcontroller, (v) The protocol of the GSM module [1]. (vi) To deal with the microcontroller and for the web page through Ethernet module [7], (vii) How to collect all the components together into PCB card to have alive. [5]

Historically, utilities have implemented power factor correction at their substations by installing banks of capacitors. The problem with implementing power factor correction at the substations is that the reactive power present on the distribution system, is not serviced by those capacitors, and it is inducing thermal losses. Furthermore, this is not including losses from reactive load that occur after the customer meters. The utility does not bill for reactive power in most cases, excess thermal losses after the meter caused by reactive load would be measured in watts and would be billed.

1.2 Objectives of this system

- ❖ Enhance equipment operation by improving voltage.
- ❖ Reduce line losses in distribution systems.
- ❖ Eliminate power factor penalties
- ❖ Increase system capacity
- ❖ Conserve energy
- ❖ Increase equipment life
- ❖ Improve energy efficiency

1.3 Effect of low Power Factor

Low power factor results in:

- a- Poor electrical efficiency
- b- Higher utility bills
- c- Lower system capacity
- d- On the supply side, generation capacity and line losses.

Power Factor Correction Capacitors (PFCC) provides an economical means for improving energy utilization.

1.4 Causes of low power factor

A poor power factor can be the result of either a significant phase difference between the voltage and current at the load terminals, Poor load current phase angle is generally the result of an inductive load such as an induction motor power transformer, lighting ballasts, welder or induction furnaces, Induction generators Wind mill generators and high intensity discharge lightings.

1.5 Benefits

- To counteract the undesirable effects of a low power factor.
- Monitoring the power factor changes using AVR and LCD in real time basis.
- Demand side management.
- Automation in power factor improvement.

2 .System Implementation

A large part of the proposed system is involved in choosing the appropriate hardware components to measure the power factor and provide a wireless link. The initial idea is to search for an all-in-one solution that would have all the components integrated, allowing for the smallest size possible. This can be implemented by a simple circuit built and attached to a microprocessor (microcontroller) to sample the voltage and current measurements.

2.1 System design

To be able to detect the active and reactive power there are three fundamental options. A System-On-Chip (SOC) that would be fully integrated and would be an all-in-one

solution and how to implement either a System-On-Chip or an Analog Front-End with a microcontroller. Another option is to use an Analog Front-End (AFE) chip attached to a microprocessor through SPI bus ports to make a comparison. The last option is to assemble a circuit to adequately obtain the power factor by a microcontroller.

Out of these options, the most appropriate and most accurate is to monitor and control the system in the real time

After further reviewing for integrated chips, there is an extensive programming requirement to implement power measurement calculations using a chip abandoned and have an Analog Front-End. After reviewing several different manufacturers, the Analog Devices ADE7763 chip was chosen for its easy accessibility and its integration of SPI bus [3]. Using SPI would allow for easy communication between the microcontroller and the Analog Front-End chip. A large amount of the AFE chips reviewed did not contain an SPI communication bus, but rather had a counter, which was mainly used for the older utility power meters.

- Features of the ADE7763:

ADCs and fixed function Digital Signal Processor (DSP) for “high accuracy over large variations in environmental conditions and time”. It incorporates two second-order, 16-bit Σ - Δ ADCs, a digital integrator, reference circuitry, a temperature sensor, and all the signal processing required to perform active and apparent energy measurements, line-voltage period measurements, and root-mean squared (RMS) calculation on the voltage and current channels / ports of the chip. The selectable on-chip digital integrator provides direct interface to di/dt current sensors such as Rogowski coils, which could be used as an interface to sample the current. The basic functional block diagram is shown in fig 1. This chip is a Single-Phase Active and Apparent Energy Metering IC. It contains two Programmable Gain Amplifiers (PGA)

and two Analog-to-Digital Converters (ADC) that achieve the basic sampling functionality of the chip. The values calculated by the internal DSP are stored in registers, which can be accessed through SPI communication.

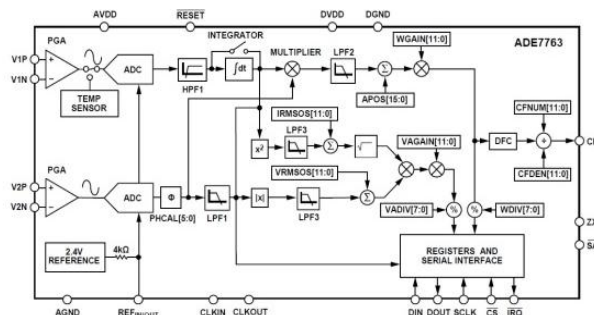

Fig 1 The ADE7763 block diagram

2.2 AVR microcontroller (ATmega32)

In an embedded system, the Micro controller is the heart of the system. Hence it must be selected correctly according to the application of the system. There are many families of microcontrollers available such as ATMEL, ATMEGA, and PIC [4] etc. In this work ATmega32 microcontroller is chosen for doing the proposed application. The following are the criteria through which a microcontroller could be selected for a particular system.

It is the main brain of the system which all the components are take orders from it (status, commands.....), connect all parts together, make all the calculations needed for the power factor ,and calculate the value of the capacitors (capacitor banks are switched according to the output) needed for the system in KVAR.

Also do the following:

- Read the analog values from the ADE Chip
- Calculate value of power factor
- Show system information on the LCD
- Find out the exact values of the capacitors needed
- Handle the communication with the external world using GSM
- Read inputs used to configure the system

- Capacitor banks are switched according to the output of AVR.

- Features of ATMEGA32:

High - performance low - power

Atmel® AVR® 8-bit high endurance

non-volatile memory Segments,

Advanced RISC architecture:

- 131 powerful instructions – most single - clock cycle execution
- 32*8 general purpose working registers
- Fully static operation
- Up to 16 MIPS through put at 16 MHZ
- Handle the communication with the external world using GSM
- On chip 2- cycle multiplier
- Low power consumptions
- High operating speed good interrupt capability.

2.3 GSM Modem

A GSM (Global System for Mobile Communication, originally from Group Special Mobile) modem is a wireless modem that works with a GSM wireless network. A wireless modem behaves like a dial-up modem, except the main difference between them is that a dialup modem sends and receives data through a fixed telephone line, while a wireless modem sends and receives data through radio waves. Like a GSM mobile phone, a GSM modem requires a SIM card from a wireless carrier in order to operate. A GSM modem can be an external unit or a PCMCIA card (also called PC Card). An external GSM modem is connected to a PC through either a serial cable or a USB cable or Bluetooth or Infrared.

GSM is the most popular standard for mobile phones in the world. It is used by over 3 billion people across more than 212 countries and territories. Its ubiquity makes international roaming very common between mobile phone operators, enabling subscribers to use their phones in many parts of the world. GSM digitalize both signals and speech channels and thus is considered as a second generation mobile phone system. This has also meant that data communication was easy to build into the system.

In this System it's used for sending every critical Power factor change over SMS Also it can receive a configuration SMS from a mobile to Configure the system or Request the Current Status of the System in order to Monitor and Control it. [2][6].

2.4 LCD Liquid Crystal Display

[1] LCDs are used as numerical indicators; especially in digital watches where there is a much smaller current needed than LED displays (microamperes compared with milliamperes) which prolongs battery life. Liquid crystals are organic (carbon) compounds, which exhibit both solid and liquid properties. The LCD display used in the system consists of many rows. Each row consists of maximum 16 characters. It's connected to the MCU to show the information of the system in a user friendly way .LCD has more features:

- Graphical Mono-color
- Graphical RGB
- Alphanumeric LCD
- Dot matrix liquid crystal display HD44780U is used.
- Can display up to one 8- character line.
- Requires a low power supply.

2.5 Capacitors Bank Board

This Board Consists of Relays connected to Capacitors, switching on/off the relays allow connecting / disconnecting Capacitor to / from the AC LINE, also it connect the loads which needed to be monitored and controlled as shown in fig 2.

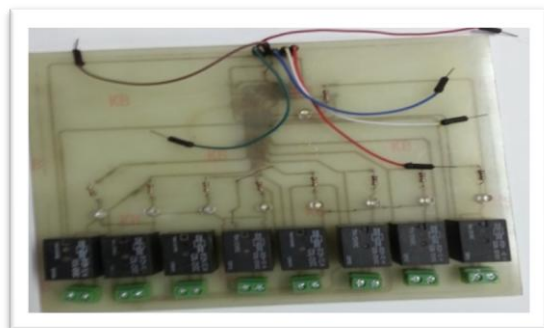

Fig 2 The capacitor board

2.6 Microcontroller power supply board

To supply energy to the measurement side of the system, it was required to design a power supply. A basic design was chosen to deliver +5VDC required for the ADE7763 chip, so it need some device to convert the AC voltage To DC and Step it down to 5v and this is the job of the power supply [6], as shown in fig 3.



Fig 3 power supply board

2.7 Firmware

In order to program the microcontroller there are multiple choices, a lot of programming languages used to do this job Such as:

- Assembly
- C
- Basic
- Flow code

C is a preferable choice for these reasons:

- It's fast
- Friendly
- Easier than assembly
- Compatible with a lot of microcontrollers
- It can be learned faster than other languages
- It has a wide support over the internet
- It allows a lot of software modularity which is very important

Used setup

When the system is powered up the microcontroller receive the active and reactive power or power factor for each load are connected to the system on relay board which is detected by the ADE chip. The MCU calculates the total power factor for the connected load in real time, then it compare this value by the stored one

(0.95)(this value are recommended by the customer),so if the value for the total load is less than the stored one rapidly it determines the value of the capacitor banks need to entered to the system to eliminate the difference between the two value ,furthermore it connects the capacitor banks through the relay board.

When the system reaches the stored value the system will be in steady state to any change of components which side by side change the value of the power factor value and also change the value of the capacitor banks.

It means that the system all the time is on the stored power factor value. Also all this steps are monitored by the mobile phone to have easy enter to the system through sending an SMS message (GSM module) appear the status of the system and on the LCD inside the place (show the power factor, connected capacitors and Average Real Power).

When the microcontroller starts working it initialize all internal peripherals then initialize all other electronic control units connected to the system (LCD – GSM – ADE –Relays) Send commands to relays board to connect/ disconnect the capacitor Find out if the power factor is critical if so it sends SMS to the mobile of the system operator read if the system received a new message with some commands as well as the web page through Ethernet protocol.

❖ Theoretical equations

Inputs for each device:

Actual (active) Power (P),Reactive Power (Q) ,Power Factor (COS φ) (PF) Interested to boost up=95%

$$Q_T = \sum_{n=1}^N Q_n \quad (1)$$

$$P_T = \sum_{n=1}^N P_n \quad (2)$$

$$Q_c = P_T * (\tan \varphi_{ref} - \tan \varphi_m) \quad (3)$$

Results

Load 1 (motor and 3 led) connected to the proposed system, the power factor for load 1 is $PF = 0.84$ on LCD as shown in fig 6, after connected the capacitor bank the power factor is equal $= 0.95$, as shown in fig 7, the oscilloscope signal after improvement is represented in fig 8.

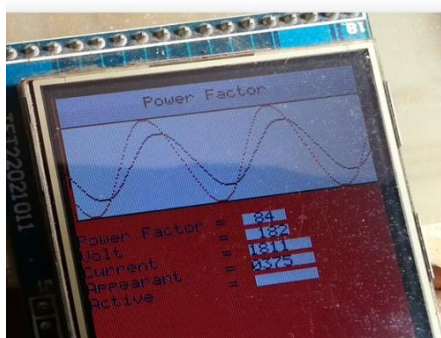

Fig 6 Load 1 before improving PF

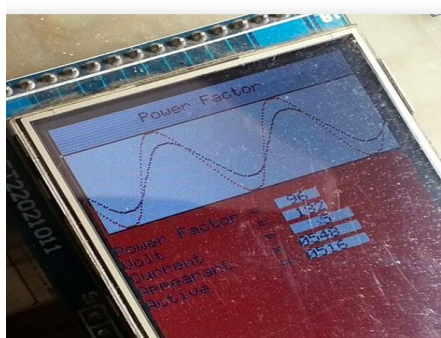

Fig 7 Load 1 after improving PF



Fig 8 oscilloscope signal after improving PF

Conclusions

The system allows a user to measure the power factor of different devices (loads) and obtain the value of the capacitor banks required for improve the power factor whichever the number of loads are connected to the system. These devices connect directly to relay board provided in the system. The volt and current values are calculated by an analog front-end integrated circuit and give active and apparent power to the microcontroller. The power factor data is sent wireless to a mobile phone through GSM module which connects the system to a customer. Power consumption data is graphed and shown in a graphical user interface.

Currently data is being transmitted in one second intervals. There are improvements that can be implemented on the system, such as provide a longer distance range for the wireless transmission by using different wireless transceivers, design a more compact power supply, and integrate multiple printed circuit boards (PCB) into one small PCB. This work also facilitates to monitor the power factor changes on LCD in real time basis. This is suitable for applications where manual switching of capacitors is to be replaced by automatic switching.

References

- [1]. V. Bhaskar & T. Gowri Manohar "GSM Based Motor Monitoring and Speed Control" proceeding of the International Journal of Mechanical and Industrial Engineering (IJMIE), ISSN No. 2231 – 6477, Volume-1, Issue-2, 2011
- [2]. H.G. Rodney Tan, C. H. Lee, and V. H. Mok, "Automatic Power Reading Using GSM Network", The 8th International Power Engineering Conference (IPEC 2007)
- [3]. kuang-yow lian, sung-jung hsiao and wen-tsai sung, " Mobile monitoring and embedded control system for factory environment" , no.1, sec. 3, zhongxiao e. rd., taipei 10608, taiwan

[4] s.m.khaled reza, shah ahsanuz zaman md. tariq, s.m. mohsin reza, "microcontroller based automated water level sensing and controlling: design and implementation issue", Proceedings of the world congress on engineering and computer science 2010 vol i wcecs 2010, october 20-22, 2010, san francisco, USA.

[5] wang wei-bin shanghai municipal, Shanghai, china, "energy-saving control device for substation air conditionings and remote management system", proceeding of the china international conference on electricity distribution (ciced2010) sept 12-16.

[6]. v.ramya, b. palaniappan, v.sumathi, "GSM based embedded system for remote laboratory safety monitoring and alerting", proceeding of the International journal of distributed and parallel systems (ijdps) vol.3, no.6, november 2012 doi : 10.5121/ijdps.2012.3604.

[7] khalid a. s. al-khateeb, wajdi f. al-khateeb and shihab a.hameed "Implementation of internet based remote control and monitoring", proceeding of the 978-1-4244-2800-7/09/\$25.00 ©2009 IEEE ICIEA 2009

[8] Milan M. Jovanovic', Fellow, IEEE, and Yungtaek Jang, Senior Member, IEEE "State-of-the-Art, Single-Phase, Active Power-Factor-Correction Techniques for High-Power Applications -An Overview", proceeding of the IEEE transactions on industrial electronics, vol. 52, no. 3, june 2005 701.

[9] oscar garcía, , josé a. cobos, , roberto prieto, pedro alou, and javier uceda, "single phase power factor correction: a survey", IEEE transactions on power electronics, vol. 18, no. 3, may 2003 749

[10]. M. M. Jovanovic', Z. Chen, and P. Liao, "Evaluation of active and passive snubber techniques for applications in power-factor-correction boost converters", in Proc. Electronica'92, 1992, pp. 105-115.

[11] R.Balamurugan, Dr.G.Gurusamy, "Harmonic optimization by single phase improved power quality AC-DC power factor corrected converters, "proceeding of

the 2010 International Journal of Computer Applications (0975 – 8887) Volume 1– No. 5.