

7-6-2020

## Emissions of Gases and Particulate Matter from Cement Plant (Case El-Mergheb Cement Factory).

Mahmoud Mahmoud

*Chemical Engineering Department, Faculty of Engineering, El-Mergheb University, Libya,*  
mhamoudchm\_2020@email.com

Ibrahim Al-Alm

*Mathematics and Physics Engineering Department, Faculty of Engineering, Mansoura University, Egypt*

Kasem El Alfy

*Prof. of Hydraulics, Mansoura University, Dean of Mansoura High Institute of Eng. And Technology,*  
amrorana2003@yahoo.com

Hamdi Abdel-Salam

*Mechanical Power Engineering Department, Faculty of Engineering, Mansoura University, Egypt*

Follow this and additional works at: <https://mej.researchcommons.org/home>

---

### Recommended Citation

Mahmoud, Mahmoud; Al-Alm, Ibrahim; El Alfy, Kasem; and Abdel-Salam, Hamdi (2020) "Emissions of Gases and Particulate Matter from Cement Plant (Case El-Mergheb Cement Factory).," *Mansoura Engineering Journal*: Vol. 40 : Iss. 1 , Article 17.

Available at: <https://doi.org/10.21608/bfemu.2020.101064>

This Original Study is brought to you for free and open access by Mansoura Engineering Journal. It has been accepted for inclusion in Mansoura Engineering Journal by an authorized editor of Mansoura Engineering Journal. For more information, please contact [mej@mans.edu.eg](mailto:mej@mans.edu.eg).

# Emissions of Gases and Particulate Matter from Cement Plant

(Case El-Mergheb Cement Factory)

انبعاثات الغازات والجسيمات من مصنع الاسمنت  
(الحالة مصنع الاسمنت المرقب)

Mahmoud Ben Mahmoud<sup>1</sup>, Ibrahim Gar Al-Alm<sup>2</sup>, Kasem El Alfy<sup>3</sup>,  
Hamdi A. Abdel-Salam<sup>4</sup>

<sup>1</sup> Chemical Engineering Department, Faculty of Engineering, El-Mergheb University, Libya - E-mail: mhamoudchm\_2020@email.com

<sup>2</sup> Mathematics and Physics Engineering Department, Faculty of Engineering, Mansoura University, Egypt

<sup>3</sup> Irrigation and Hydraulic Engineering Department, Faculty of Engineering, Mansoura University, Egypt

<sup>4</sup> Mechanical Power Engineering Department, Faculty of Engineering, Mansoura University, Egypt

## ملخص

تقدر انبعاثات الغازات والجسيمات من مصنع للاسمنت بورتلاند بالقرب من مدينة الخمس في شمال غرب ليبيا عن طريق استخدام تطبيق برنامج (READY) التي أنتجته الهيئة القومية الأمريكية للمحيطات والغلاف الجوي ويقوم التطبيق بحساب تركيز الملوث لعدد من نقاط (X) و (Y) حول مصدر انبعاث الملوثات بدائرة قطرها (20 كم) , تكشف عن أن انبعاثات الغازات والانبعاثات الغبار تتجاوز حدود المعايير المصرية . النتائج تسلط الضوء على الحاجة إلى تحسين الإجراءات التشغيلية للحد من الانبعاثات وتجنب أي آثار بيئية سلبية محتملة.

## Abstract

Estimated emissions of gases and particulate matter from Portland cement plant near Khoms city in northwestern Libya by The use of the application program (READY), which was produced by the (United States National Oceanic and Atmospheric Administration) application calculates the contaminated concentration of a number of points (x) and (y) about the source of emission of pollutants circle diameter (20 km), reveal that the gases emissions and dust emissions exceed selected Egypt standard limits. The results highlight the need for improved operational procedures to minimize emissions and avoid any possible adverse environmental effects.

## Keywords

CO, CO<sub>2</sub>, SO<sub>2</sub>, NO<sub>x</sub>, PMs, air pollutants, emissions, Cement, Mergheb.

## 1. Introduction

Cement production in Libya faces many of the problems found in both the developed and the developing world. The industry is fundamental to the

success of Libya's attempt to industrialise and will necessarily have a negative impact on the environment both globally and locally. Emissions

from natural gas combustion and raw cement burning can cause negative effects on public health and lead to degradation of the surrounding environment. Several health problems such as respiratory disorders and allergies are attributed to such emissions [1].

This study aims to calculate the concentrations of emissions from cement plant using application program (READY) and know the limits of the spread of pollutants directly from the map.

## 2. Problem statement

That Mergheb Cement Plant provides a significant positive socio-economic impact related to the potential increase in job opportunities for locals as well as providing a product that is much needed to meet the demand for the construction and development activities that are occurring on the national scale. In contrast, several potential adverse impacts can negatively affect the environment particularly those associated with emissions, effluent discharge, and waste generation. In the absence of control measures, the assessment of current and projected emissions indicated that Mergheb Cement Plant operations may result in serious exposure to particulate matter for nearby receptors and the plant workforce.

## 3. Previous works

**Latha and Shanmugam** [2]. This study describes the atmospheric dispersion modeling using SO<sub>2</sub> for the urban city of Ahmadabad, (India) during the month of February, July, and August. 1992. The stability categories,

mixing height and X<sub>1</sub> and Y<sub>1</sub> values were calculated from different cloud cover data and using the turner's stability categories. The air quality due to the release of sulphur dioxide from the thermal power plant of Ahmadabad within the radius of 7 km has been computed by employing the Gaussian dispersion model. The computed air quality was based on the meteorological data in the month of February, July, and August obtained from M.S. Naik, 1992. The computation points were done at every 500m up to 7 km in 16 directions using FORTRAN 77. The scatters and contours of the SO<sub>2</sub> concentration of each month were then plotted and compared with those from the published paper. The factors that caused the discrepancies between the obtained results and the paper's results were also discussed. The dispersion pattern at different X<sub>1</sub> and Y<sub>1</sub> values were evaluated.

**Shalini Anand, et al** [3]. A system dynamics model based on the dynamic interactions among a number of system components is developed to estimate CO<sub>2</sub> emissions from the cement industry in India. The CO<sub>2</sub> emissions are projected to reach 396.89 million tonnes by the year 2020 if the existing cement making technological options are followed. Policy options of population growth stabilisation, energy conservation and structural management in cement manufacturing processes are incorporated for developing the CO<sub>2</sub> mitigation scenarios. A 42% reduction in the CO<sub>2</sub> emissions can be achieved in the year 2020 based on an integrated mitigation scenario. Indirect CO<sub>2</sub> emissions from the transport of raw materials to the cement plants and finished product to market are also estimated.

**Shraddha and Nehal** [4]. Climate change is considered as major environmental challenge for the world. Emissions from cement manufacturing are one of the major contributors in global warming and climate change. Cement manufacturing is a highly energy intensive process, which involves intensive fuel consumption for clinker making and resulting in emissions. Beside Fuel consumption, the calcining process is a major source of emissions such as  $\text{NO}_x$ ,  $\text{SO}_x$ ,  $\text{CO}_2$ , particulate matters etc. In this paper, the role of cement industry is reviewed in causing impact on environment and health. It describes the cement production process and its emission sources followed by overview of emissions and their environmental and health impacts. Review study has focused on emission generation from clinker production and excluded the emissions due to indirect energy (electricity, transportation, supply chain etc.) used for cement operations. This review observed a comprehensive literature in term of peer reviewed journals, industry sector reports, websites etc on cement industry and associated emissions and health impacts.

#### 4. Process description

**El-Mergheb Cement Factory:** It is located in the Khoms area, 120 km to the east of Tripoli and the neighboring ancient Roman city of Leptis Magna and surrounded by farming areas with an annual production capacity of 33000 tons and started production in 1969.

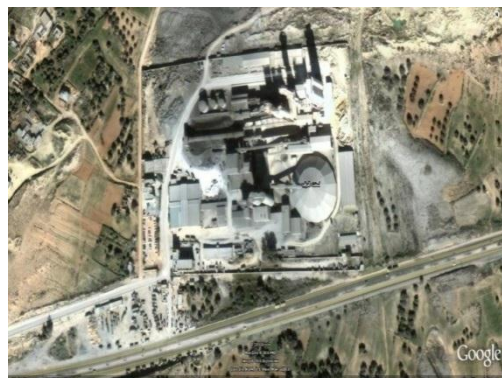

Figure (1) El-Mergheb Cement Factory



Figure (1) El-Mergheb Cement Factory

#### The operational data used [5, 6, 7]

- Plant design capacity = 1,100 tons of clinker/day (300 day/year);
- Furnace operational capacity = 1,000 tones clinker/day;
- Amount of feeding into the furnace = 1,680 tons/day;
- Type of fuel: natural gas;
- Fuel supplier: Sirte Oil & Gas Company;
- Sulfur content in fuel = 0.0009 g/m<sup>3</sup> [essentially is representative of the gas hydrogen sulfide];
- Combustion furnace temperature = 1,500 C°;
- Amount of excess air = 40%.

**Table (1) Chemical composition of the raw material feeding the furnace of Mergheb cement plants [5, 6]**

Component	Kiln feed
SiO <sub>2</sub>	14.43
Al <sub>2</sub> O <sub>3</sub>	3.9
Fe <sub>2</sub> O <sub>3</sub>	2.27
CaO	42.61
MgO	1.09
SO <sub>3</sub>	0.1
K <sub>2</sub> O	0.9
Na <sub>2</sub> O	0.09
LOI	34.61
<b>Total</b>	<b>100</b>
CaCO <sub>3</sub> content	76.09

### Chemical Reactions in Rotary Kiln and Pollutants Formation

The amount of combustion gases generated from the same amount of thermal units of natural gas is 18.5% and 12.2% higher than that generated from coal and fuel oil respectively. Higher volumes of combustion gases released from natural gas combustion are attributed to air requirement. Combustion of fuel oil requires lesser amounts of air than natural gas. The increased air requirement for combustion results in lower flame temperature from natural gas as compared to others fuels, higher gas velocities inside the rotary kiln resulting in a lower heat exchange rate from the gas to the kiln charge, and higher kiln exit gas volumes and thus higher heat losses with the exit gases. The recommended flame temperatures for optimum use are within 1,200-1,600 C° in cement industry by dry process in Libya. This range of flame temperatures corresponds to excess air within 90%-30% for natural gas combustion as reported [7].

**Table (2) Composition of natural gas used as fuel [7]**

Composition	Value	Unit
N <sub>2</sub>	0.593	mol.%
CO <sub>2</sub>	2.023	mol.%
CH <sub>4</sub>	86.482	mol.%
C <sub>2</sub> H <sub>6</sub>	10.392	mol.%
C <sub>3</sub> H <sub>8</sub>	0.496	mol.%
i-C <sub>4</sub> H <sub>10</sub>	0.014	mol.%
<b>Total</b>	<b>100</b>	<b>mol.%</b>
M.Wt.	18.282	kg/kgmol
Density	0.7751	kg/Nm <sup>3</sup>
T.S.	9	g/Nm <sup>3</sup>
	0.0009	

### Combustion of Natural Gas [7]

The main reactions associated with natural gas Table (2) combustion are as follows:

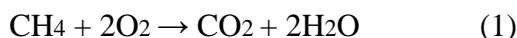

With conversion rate of 100% at the main reactions are accompanied the following side reactions:



The reactions are with conversion rates of 100% of H<sub>2</sub>S and 0.5% of incoming nitrogen to the kiln.

### Decomposition of Feedstock [7]

The main reactions of feedstock are as follows:

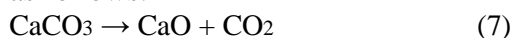

These chemical reactions tend to initiate formation of complex compounds through a chain of reactions that lead to formation of clinker. It is suggested that all SO<sub>3</sub> emitted from feed stock converts into SO<sub>2</sub> and half of the sulfur content emits with combustion gases as follows:

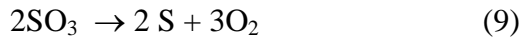

### Unit Operations and Processes in Cement Manufacturing

Cement is made by heating a mixture of calcareous and argillaceous materials to a temperature of about 1450 C°. In the process, partial fusion occurs and nodules of so-called clinker are formed. The cooled clinker is

mixed with very small quantities of gypsum, and sometimes other additives, and ground into a raw meal. A brief overview of cement manufacturing process is illustrated in Fig (2) [7].

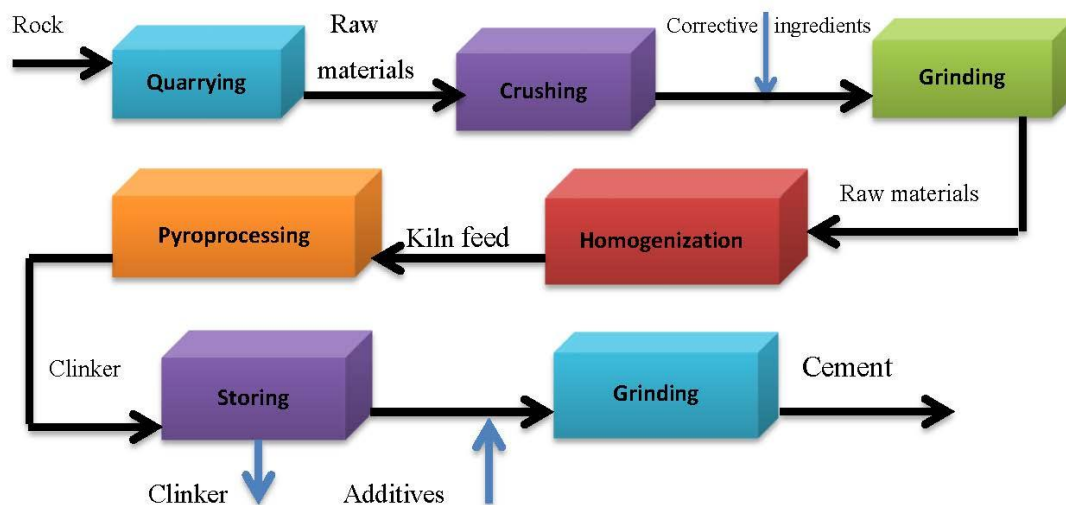

Fig (2) process flow diagram for cement production at El-Mergheb Cement Factory

### The Environmental impact of cement manufacturing (Air emissions)

Air pollution from Cement manufacturing is becoming an environmental problem worldwide. Recent studies determine relationship between cement air pollution and human health diseases. Pollutants from cement plants are causing harmful effects on human health and environment [8].

Details the typical production process for the manufacture of cement and at each stage there is the potential for pollution generation. Figure (3) Data sheet for Quantities of Gases and Dust Emissions in Mergheb cement plants [6].

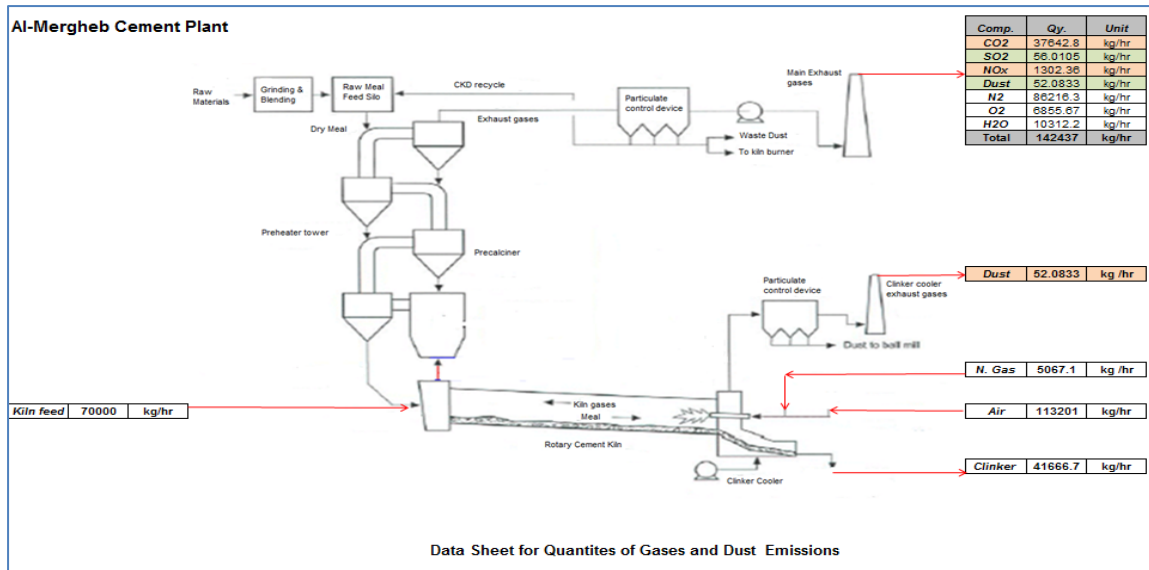

Figure (3) Data sheet for Quantities of Gases and Dust Emissions.

### 5. Mathematical Model

Mathematical models for the spread and dispersion of pollutants in the environment is one of the tools to sign and conclude the concentrations of pollutants near the emission sources and on different dimensions, and the nature of the models vary depending on the source of emission type being located on the surface of the ground or at a height of it, or the source occupies a specific area of the ground or in the form of road, or that the contaminated gas or particles, and the type of model depends also on patrol emissions, ongoing emissions, and annual or monthly or daily, Intervention in air emissions happens composed by acid rain through acid deposition reactions . A program to calculate the concentrations of emissions development after emissions from the source, and one of the most important models used to calculate

the expected concentrations of pollutants at different points near and away from the source is the (Gaussian Dispersion Model), concluded Gaussian model for the cloud for a gradual transition theory and statistical theories in the middle of the last century. It has been used out of a form in the distribution of concentrations of molecular spread measurements, It also has been applying the model to calculate the concentrations of pollutant emitted from the source and spreads in the middle of homogeneous turbulence fluid (air) as in Figure (4) has been considered the basic model and more importantly, to set the air spreading and because it gives the results of a high degree of compatibility with practical results. Figure (5) pattern, which exposures its emissions and how it spreads and dispersed it into the atmosphere.





Figure (4) the stacks gases exit and move with the direction of the wind.

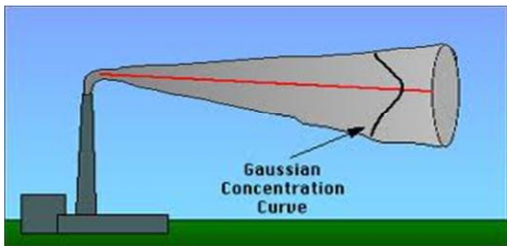

Figure (5) the pattern gas exit and dispersion of emissions into the atmosphere.

And the mathematical foundation for this model, implies that the average concentration for a particular pollutant emitted from a particular source follows a Gaussian distribution under certain standard conditions, as shown in Figure (6) and Figure (7) shows the coordinates of the system spreading

regime, and assuming that the origin point is located at the level of ground or directly down the source of emission, and the axis (x) extends horizontally in the direction of the wind, the axis (y) is perpendicular to the horizontal plane axis (x), and the axis (z) is the vertical.

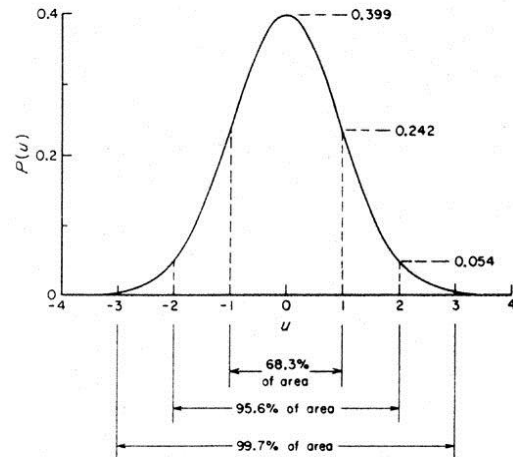

Figure (6) Normal (Gaussian) distribution

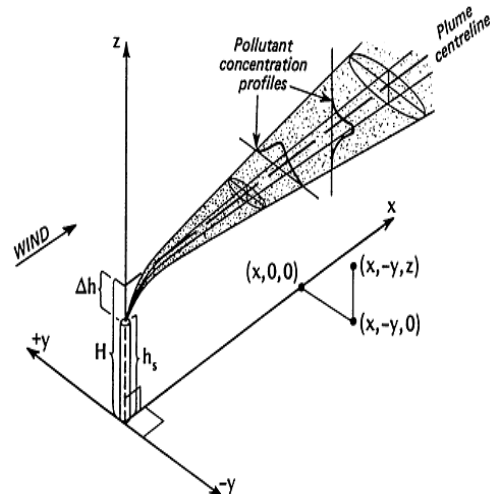

Figure (7) Coordinates system for Gaussian plume equation [9].

The Bottom equation is the Gaussian equation which estimates ground level pollution concentrations within 50 km of a source [10].



$$C = \frac{Q}{2\pi u \sigma_y \sigma_z} \exp\left(\frac{-y^2}{2\sigma_y^2}\right) \left\{ \exp\left(\frac{-(z-H)^2}{2\sigma_z^2}\right) + \exp\left(\frac{-(z+H)^2}{2\sigma_z^2}\right) \right\}$$

Where:

$C = C(x,y,z)$  is the concentration of the emission in (mg /m<sup>3</sup>)

$Q$  = Pollutant emission rate in mass par time, (g / sec).

$U$  = is the average wind speed at stack height, meters per second (m / sec).

$y$  = is the crosswind distance from the plume center line, (m).

$x$  = is the distance downwind from the chimney, (m).

$z$  = is the vertical distance from the ground level, (m).

$\sigma_y$  and  $\sigma_z$  = are the standard deviations of the plume concentration in the horizontal and vertical directions respectively.

$H$  = effective stack height.

The effective stack height formula is as follows:

$$H = h_s + \Delta h$$

Where:

$h_s$  = is the stack height

$\Delta h$  = is the plume rise (above stack)

Another plume rise equation is the Holland formula [11]:

$$\Delta h = \left(\frac{v_s d}{u}\right) (1.5 + 2.68 \times 10^{-3} p(\Delta T) d / T_s)$$

Where:

$v_s$  = is the stack exit velocity (m/s).

$p$  = pressure, millibar (mb).

$u$  = average wind speed (m/s).

$d$  = is the diameter of the stack (m).

The effective temperature formula is as follows:

$$\Delta T = T_s - T_a$$

Where:

$T_s$  = temperature of stack gas (k).

$T_a$  = atmospheric temperature (k).

The dispersion parameters ( $\sigma_y$ ) and ( $\sigma_z$ ) are determined using Pasquill-Gifford stability classes. The pollutant is assumed to be non-reactive and its removal and transformation rates are not considered. The area terrain is assumed to be flat and the height of the receptor is (1m) above the ground.

The dispersion parameters ( $\sigma_y$ ) and ( $\sigma_z$ ) are given from Martin's equation [12]:

$$\sigma_y = ax^{0.894}$$

$$\sigma_z = x^d + f$$

Where constant values of ( $a$ ,  $c$ ,  $d$  and  $f$ ) could be determined from Table (3).

The atmospheric stability was then determined from Table (3) and (5) used on the average wind speed, the cloudiness, and the daytime insolation.

This model applies the hypothesis that there is no spread, but there are only into force in the direction (x).

Stability	$X \leq 1$ Km				$X \geq 1$ km		
Type	a	C	D	f	C	D	F
A	213	440.8	1.194	9.27	459.7	2.094	-9.6
B	156	1.149	1.149	3.6	108.2	1.098	2.0
C	104	0.911	0.911	0.0	61.0	0.911	0.0
D	66	0.725	0.762	-1.7	44.5	0.516	-13
E	50.5	0.678	0.678	-1.3	55.4	0.305	-34
F	34	0.740	0.740	-0.35	62.6	0.180	-48.6

Table (3) Guidelines for determining Pasquill-Gifford stability [12]:

In the lower layers of the atmosphere, wind speed normally increases with height. Most national weather service wind speed measurements are taken at a height of 10 m above the surface and are listed as “ground level” wind speeds. The wind speeds at stack height has the greatest effect on the plume. Wind speeds may be adjusted to stack height with the following equation:

$$(U_z/U_{10}) = (Z/10)^p$$

Where:

$U_z$  = is the Wind speeds at height z.

$U_{10}$  = is the Wind speeds at anemometer height.

$Z$  = is the desired height.

$p$  = is defined in table (4) as a function of atmospheric stability class.

Atmospheric Stability Type	A	B	C	D	E	F
Wind exponent ,p	0.15	0.15	0.2	0.25	0.4	0.6

Table (4) Wind exponent as a function of atmospheric stability type [13]:

Surface wind Speed (at 10m) (m/s)	Daytime insolation			Night	
	Strong	Moderate	Slight	$\geq 4/8$ low cloud cover	$\leq 3/8$ cloud cover
< 2	A	A-B	B	E	F
2-3	A-B	B	C	E	F
3-5	B	B-C	C	D	E
5-6	C	C-D	D	D	D
> 6	C	D	D	D	

Table (5) Pasqual Stability Types [10]:

Where:

A = extremely unstable,  
B = moderately unstable,

C = slightly unstable,

D = neutral,

E = slightly stable,

F = moderately stable.

The weather conditions F and D 'the worst kind of weather conditions in terms of increasing concentrations of pollutants in the region.

Blinders: defined as the part of the sky covered with clouds for the whole area of the sky in the selected area.

Evening time: is the corresponding period of an hour before sunset until an hour before sunrise.

The wind speed is determined by the average wind speed over the year, as shown in the table (6).

Table (6) the average wind speed in the range of Al- Khoms city throughout the year [14].

Month	Wind speed (m/sec)
January	3.7
February	4
March	3.9
April	4.1
May	3.6
June	3.2
July	2.8
August	3.1
September	3.4
October	3.2
November	2.8
December	4

It is clear that the wind speed in the region ranging from 2.8 m / s and 4 m / s and the speed measurements will be below the speed between 2.6 m / s and 4.2 m / s, near the ground and this represents the border range between the speed values at a height of 2m.

The method of calculating the spread of contaminant using the Gaussian model:

The use of the application program (READY), which was produced by the

(United States National Oceanic and Atmospheric Administration)

application calculates the contaminated concentration of a number of points (x) and (y) about the source of emission of pollutants circle diameter (0-50 km) taking into consideration wind direction and speed, and there are in the program databases temperature and climate conditions in all regions around the world where the constants used in the calculation involved in the spread of the Gaussian equation to give the maximum possible accuracy. The application also signed the contour lines of the special focus on Google contaminated dimensional maps to make it easier to know the limits of the spread of pollutants directly from the map.

To locate the factory coordinates in the Programme by using the coordinates of (El-Mergheb Cement Factory) and are as follows:

LONGITUDE (deg) 14.22°

LATITUDE (deg) 32.63°

And as well [6];

- Height of chimney 55 m
- Diameter of chimney 3.1 m
- Pollutant emission rate 39750 g/ sec
- Gas exit velocity 7.4 m/sec
- Concentration gaseous pollutants 209420 mg/m<sup>3</sup>
- Temperature of emitted gas 410 K

The modeling work for the spread of contaminants in different situations for the direction of the wind and expectation on Google map as shown in the following section notes that the contaminated concentration unit used is (mg / cubic meter) as an outputs of each case.

## 6. Results and Discussions

### In the case of a Northern wind

Cloud Ceiling (feet): 20000  
 Wind Speed (m/s): 3.5  
 Wind Direction (deg): 0  
 Cloud cover (%): 50  
 Year: 2014  
 Month: 12  
 Day: 28  
 Hour: 12

DISPERSION PRODUCT  
 BASED ON 1200 UTC 12/28/2014 OBSERVATIONS

DAY-HOUR		DOWNWIND DISTANCE (KM)							
DIRECTION		2.0	4.0	8.0	12.0				
16.0	20.0								
29-11UTC	TRAVEL (min.)	6	13	26	39				
51	64								
S	AVERAGE (s/m3)	1	2	1	1	1	1	1	1
1	1	1							
	PEAK (s/m3)	1	2	1	2	1	1	1	1
1	1	1							

#### Model Diagnostics

```

*****
YEAR                14
MONTH               12
JULIAN-DAY         362
JULIAN-HOUR        12
LOCAL-HOUR         12
LATITUDE (deg)    32.63
LONGITUDE (deg)   14.22
CLOUD COVER (%)   50.0
WIND SPEED (m/s)  3.5
CEILING (FEET)    20000
SOLAR ELEV (deg)  32
DOWNWIND DIR (deg) 180
PG STABLITY CLASS  C
MIXING DEPTH (M)  400.0
SUNRISE            6.0

```

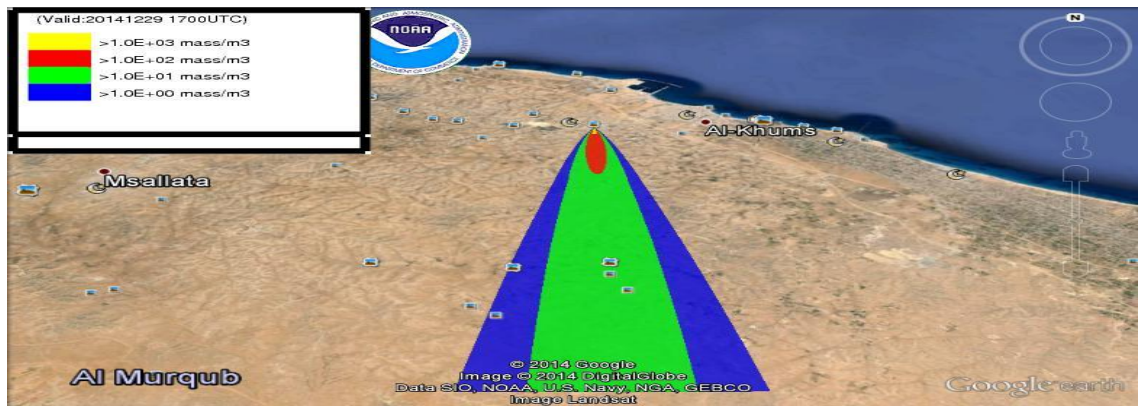
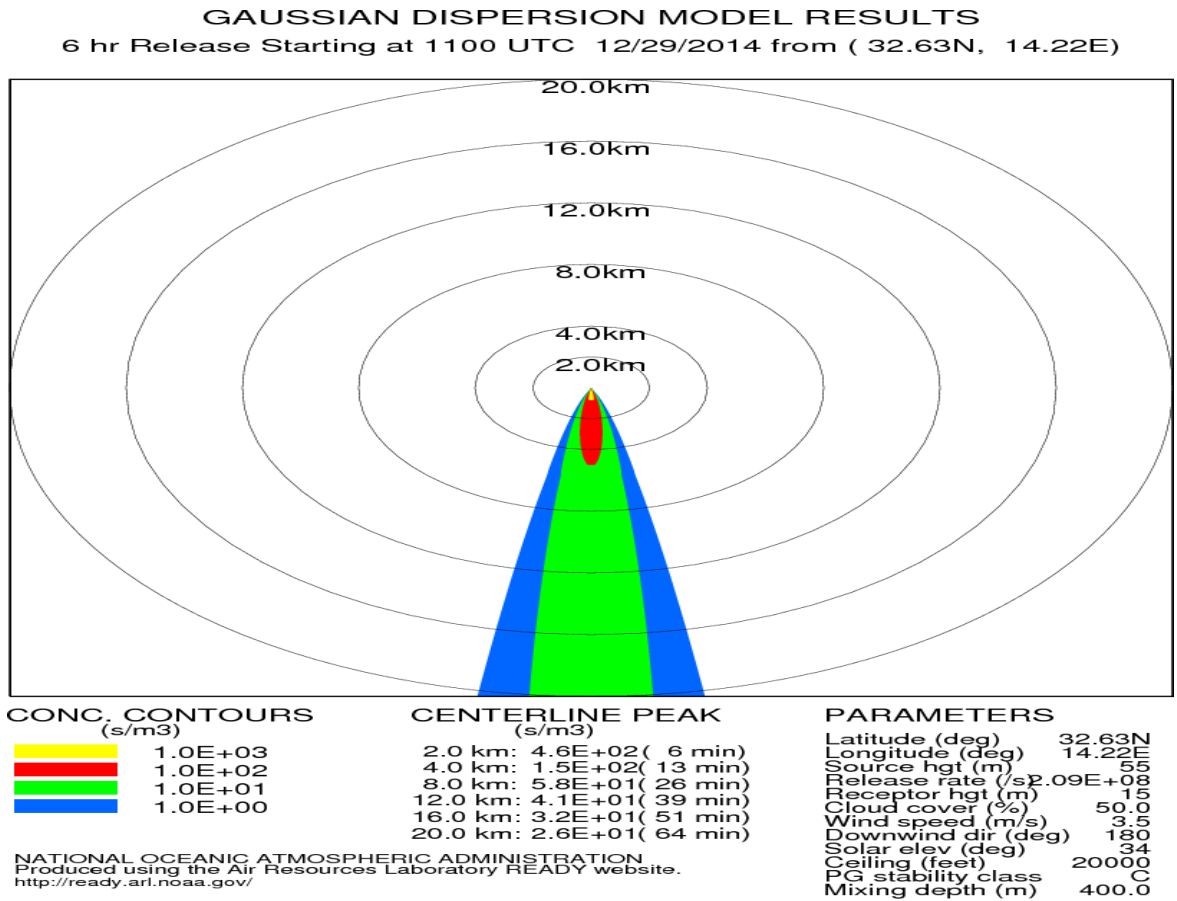

From the previous results we can expected that emissions from cement production processes represent serious problem, and is a real source of contamination to the surrounding environment and population scope intimate as the yellow area in the results of modeling environmental

loads expression the concentrations of contaminants in the range of 1000 mg / m<sup>3</sup> is marked as red zone expression concentrations in the range of 100 mg / m<sup>3</sup>, green Zone expression is the concentrations in the range of 10 mg / m<sup>3</sup>, and blue Zone expression is the concentrations in the range of 1 mg / m<sup>3</sup>.

Distance (km)	2	4	8	12	16	20
Peak value for the concentration of gaseous emissions (mg/m <sup>3</sup> )	1000	1000	100	100	100	100
Average value for the concentration of gaseous emissions (mg/m <sup>3</sup> )	100	100	10	10	10	1
Limits of the law 4 of 1994 [15]	Border The maximum Before the amendment 500 (mg/m <sup>3</sup> ) and After the amendment 300 (mg/m <sup>3</sup> )					

Table (7) shows the maximum value (Peak) and medium value (Average) concentrations of gaseous emissions at different distances.

## Conclusions

Such a plant as “El-Mergheb Cement Factory” with production capacitance of (330,000 tons) needs a study showing the surrounding environment of the plant in addition to many important study elements such as environmental impacts analysis, and emissions reduction options. As it represents a great social and economic value providing work opportunities for young people and producing such an important substance as “cement” fulfilling the raising demand on building and construction process. As a tax, probable negative side effects which may affect the environment badly stick to the emissions, sanitary, and the solid wastes as result of production.

Current studies refer to high probability of observable changes in the direct surrounding area of the plant especially with the absence of emissions control devices. Many other bad indicators refer to harmful changes in vehicles transportation, noise levels, underground and shallow depth water, soil components, biological variation, natural resources, landscapes, and cleanliness.

It's soon obvious that probable side effects accompanying cement production industry at “El-Mergheb plant” are controllable and can be limited through assurance of effective decisions to overcome the bad effect on the environment and by applying environmental observation and training system to execute the decisions taken by the administration. In the same context, I suggested many proposals to reduce/overcome the side effects which would give addition acceptance for the project plant.

## References

- [1] **Pollution Prevention and Abatement Handbook 1998 toward Cleaner Production;** World Bank Group, International Finance Corporation, Washington D.C., (1999).
- [2] **Latha. S, Shanmugam. P.;** “Atmospheric Gaussian Dispersion Modelling for Air Pollution Mapping in the urban city of Ahemadabad”, (2010).
- [3] **Shalini Anand , Prem Vrat , R.P. Dahiya.;** “Application of a system dynamics approach for assessment and mitigation of CO<sub>2</sub> emissions from the cement industry”, (2005).

- [4] **Shraddha Mishra, Nehal Anwar Siddiqui;** “A Review On Environmental and Health Impacts Of Cement Manufacturing Emissions”, (2014).
- [5] **Aldieb,M.A.; Ibrahim, H.G.;** “Variation of feed chemical composition and its effect on clinker formation–simulation process, in: Proceedings of the World Congress on Engineering and Computer Science (WCECS 2010)”, San Francisco, Vol.II, Oct, (2010).
- [6] **El-Mergheb Cement Factory;** “personal communication with Head of Operation Department”, Elkhmos, Libya, August, (2014).
- [7] **Ibrahim, H.G.; Aly, Y.O.; Mokhtar, S.E.; and Al-Meshragi, M.A.,** “Emissions of SO<sub>2</sub>, NO<sub>x</sub> and PMs from Cement Plant in Vicinity of Khoms City in Northwestern Libya”, Journal of Environmental Science and Engineering, May 20, (2012).
- [8] **Rai Priyanka, Mishra RM and Parihar Sarita;** Quantifying the Cement Air Pollution related Human Health diseases in Maihar city, MP, India, (2013).
- [9] **Turner, D.B.;** Workbook of atmospheric dispersion estimates (Revised). Office of Air Programs Pub. No. AP-26 (Research Triangle Park, N.C.:U.S. EPA), (1970).
- [10] **Canter, L.W.;** “Environmental Impact Assessment” (Second Edition), Published by McGraw-Hill Inc. Pp. 2-175, (1996).
- [11] **Schnelle K.B;** Dey, Atmospheric Dispersion Modelling Compliance Guide (McGraw-Hill, Europe), (1999).
- [12] **Martin, D.O.;** “The change of concentration Standards Deviation with Distance”, Journal of the AIR pollution Control association, (1976).
- [13] **U.S. Environmental Protection Agency (EPA);** “Screening Procedures for Estimating the Air Quality Impact of Stationary Sources, Revised”, Research Triangle Park, North Carolina 27711, October (1992).
- [14] **The National Meteorological Center;** “personal communication with factor in Department”, Al Khoms, Libya, August, (2014).
- [15] **Egyptian Environmental Affairs Agency (EEAA),** Guidelines of Egyptian environmental impact assessment principles and procedures (2nd ed.). Cairo: (2009).