

7-8-2020

A Study on Spiral Bevel Gears with Circular Arc Tooth Profile.

Tawfik Elmidany

Prof. at Production and Mechanical Design - Faculty of Engineering - Mansoura University

Ibrahim Elewa

Professor of Production Engineering., Mansoura University, dr_elewa@mans.edu.eg

Mostafa El-Bahloul

Demonstrator, Faculty of Eng., Mansoura University, m_elbahloul@mans.edu.eg

Follow this and additional works at: <https://mej.researchcommons.org/home>

Recommended Citation

Elmidany, Tawfik; Elewa, Ibrahim; and El-Bahloul, Mostafa (2020) "A Study on Spiral Bevel Gears with Circular Arc Tooth Profile.," *Mansoura Engineering Journal*: Vol. 40 : Iss. 3 , Article 10.

Available at: <https://doi.org/10.21608/bfemu.2020.101488>

This Original Study is brought to you for free and open access by Mansoura Engineering Journal. It has been accepted for inclusion in Mansoura Engineering Journal by an authorized editor of Mansoura Engineering Journal. For more information, please contact mej@mans.edu.eg.

A Study on Spiral Bevel Gears with Circular Arc Tooth Profile

دراسة عن التروس المخروطية الحلزونية ذات الأسنان الدائرية الجانبية

Tawfik T. El-Midany^a, Ibrahim M. Elewa^b, and Mostafa A. El-Bahloul^c

^a Professor of Production Engineering, Mansoura University, E-mail: midany@mans.edu.eg

^b Professor of Production Engineering, Mansoura University, E-mail: dr_elewa@mans.edu.eg

^c Demonstrator, Faculty of Eng., Mansoura University, E-mail: m_elbahloul@mans.edu.eg

المخلص

الهدف من هذا البحث هو دراسة التروس المخروطية باسنان لها شكل جديد بحيث يحقق هذا الشكل مجموعة من الفوائد. تشمل هذه الفوائد سعة تحميل اكبر، كفاءة أعلى في نقل القدرة، وعمر اطول للتروس، وذلك بالمقارنة بشكل السنة التقليدي Involute. يطلق علي هذا الشكل التروس ذات الأسنان الجانبية الدائرية. في هذا البحث، تم تقديم نمذجة رياضية للتروس المخروطية الحلزونية ذات الاسنان الدائرية الجانبية، بحيث تمت كل العمليات الرياضية والحسابية باستخدام برنامج MATLAB. أشتملت النمذجة الرياضية على التروس المخروطية المصنعة لكل من شركتي تصنيع التروس Gleason و Klingelberg. في النمذجة الرياضية، تم الأخذ في الاعتبار المعادلة الحاكمة لحركة التعشيق بين اسنان التروس، وتم استخدامها ايضا في الحسابات الخاصة بهندسية التروس المخروطية. تم التأكد من النمذجة الرياضية المقدمة في هذا البحث عن طريق عمل نمذجة مجسمة صلبة باستخدام برنامج CATIA. تم عمل العديد من المحاولات للتأكد من صحة النمذجة الرياضية، والتي روعي فيها اختيار قيم مختلفة للمتغيرات التصميمية المختلفة للتروس المخروطية، وذلك للتأكد من أن النموذج الرياضي صالح للاستخدام في التصميمات المختلفة. تم التأكد أيضا من صحة النموذج الرياضي المقدم عن طريق عمل اختبار تداخل بين أسنان التروس من خلال عمل محاكاة ديناميكية للحركة الدورانية بين التروس وهم في حالة التعشيق باستخدام برنامج CATIA.

Abstract

The aim of this paper is to study the spiral bevel gears with new tooth profile, named circular arc. This profile will guarantee higher load carrying capacity, higher power transmission efficiency, and longer operating life. A mathematical model is proposed for spiral bevel gears having circular arc tooth profile, where all geometry calculations are performed using MATLAB software package. The mathematical model includes spiral bevel gears for both Gleason and Klingelberg manufacturing systems. The solution of the single meshing constraint equation for gears with intersecting axes is taken into consideration for gear geometry calculations. The proposed mathematical model is then validated using CATIA software package through solid modelling of different gear designs. These trials included different values of the various design parameters of spiral bevel gears to ensure that the mathematical model is valid for different design cases. This validation is completed with an interference check step performed through dynamically simulating meshing between a pair of gear set through CATIA software package.

Key Words

Spiral bevel gears; Circular arc tooth profile; Gleason; Klingelberg

Nomenclature

r	Sphere radius at calculation point	β	Angular parameter of N plane
δ	Angular parameter of pitch line (Pinion half pitch cone angle)	ρ	Perpendicular distance from contact point to pitch line
Σ	Shafts angle	l	Projected length of contact point on pitch line
α	Angular parameter of N plane (Pressure angle)	λ	Angle between pitch line and contact point

- $\lambda_{1,2}$ Half cone angle of tooth
 - $r_{1,2}$ Position vector of contact path for gear tooth
 - r_P Position vector for contact point in S_{1F} system
 - $L_{1,2}$ Gears shaft axes
 - $S_{1,2F}$ Fixed coordinate system
 - $S_{1,2M}$ Movable coordinate system
 - S_{ISA} Screw line coordinate system
 - $S_{1,2T}$ Tooth coordinate system
 - $r_{1,2C}$ Conical tooth profile in $S_{1,2F}$ systems
 - $r_{1,2CT}$ Conical tooth profile in $S_{1,2T}$ systems
 - $\theta_{1,2CT}$ Angle of rotation for conical tooth
 - $r_{1,2CL}$ Conical tooth profile in $S_{1,2M}$ systems
 - $r_{1,2Cy}$ Cylindrical tooth profile in $S_{1,2F}$ systems
 - $r_{1,2CyT}$ Cylindrical tooth profile in $S_{1,2T}$ systems
 - $r_{Cy1,2}$ Cylindrical tooth radius
 - $\theta_{1,2CyT}$ Angle of rotation for cylindrical tooth
 - $r_{1,2CyL}$ Cylindrical tooth profile in $S_{1,2M}$ systems
 - $\phi_{1,2}$ Gears angle of rotation
- Subscripts: ₁ for pinion, ₂ for gear

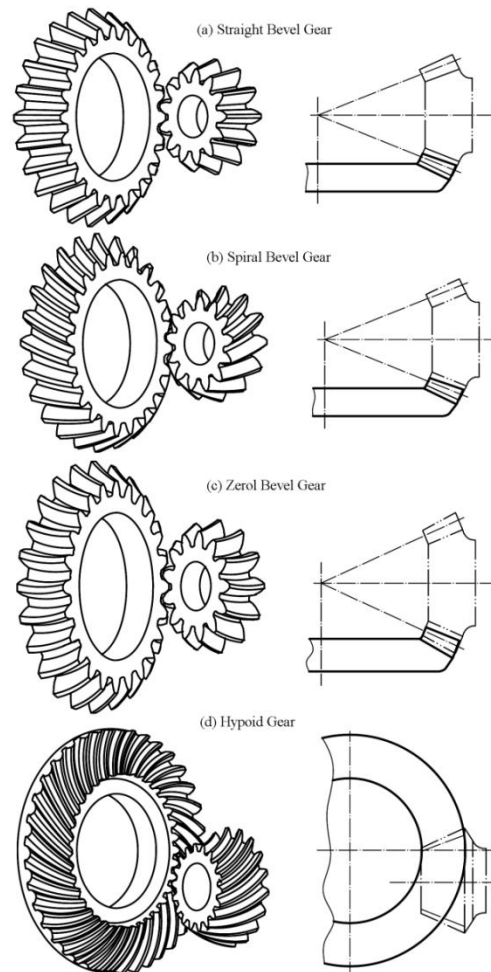

Figure 1 – Bevel gear types [3].

They are generally classified into straight bevels, spiral bevels, zerol bevels and hypoids. The main difference between the first three types is the tooth form, while the fourth type is different in having an offset between the two shaft axes, as shown in Fig.1.

Gears have generally an involute tooth profile. In this paper, it is required to increase the load carrying capacity and power transmission efficiency of spiral bevel gears. This can be achieved by increasing the radius of curvature of tooth profile for both pinion and gear. This can be done by making gears with a circular arc tooth profile, shown in Fig.2, instead of the involute tooth profile for both spiral bevel gears manufacturing systems, Gleason and Klingelnberg, shown in Fig.3.

1. Introduction

Gears can be classified in many different ways. Considering Kinematics, gears can be categorized into three different types depending on the type of shafts they are mounted on. First, parallel axes such as spur and helical gears, termed plane mechanisms. Second, intersecting axes such as bevel gears, termed spherical mechanisms. Third, two non-parallel and non-intersecting axes such as hypoid, crossed helical, and worm gears, termed spatial mechanisms [1, 2].

Bevel gears, shown in Fig. 1, are suitable for transmitting power between shafts at practically any angle or speed. However, the particular type of gear best suited for a specific application is dependent upon the mountings, available space, and operating conditions [3].

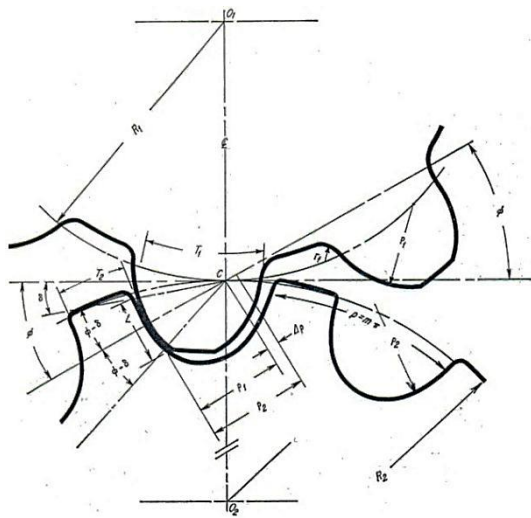

Figure 2 – Circular arc teeth [4].

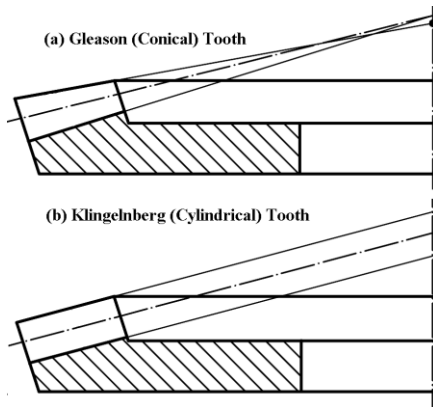

Figure 3 – Conical and Cylindrical Tooth [3].

1.1 Literature Review

Tsai and Sung [5] deduced the mathematical models to describe the conjugate tooth profile of gear set with skew axes. They also derived the only constraint of parametric conjugate tooth profile and investigated the point contact types of gear sets with skew axes. Tsai and Jehng [1] presented a parametric mathematical model for spherical gear sets with skew axes based on kinematics of spherical mechanisms. The validation of presented information is done through using rapid prototyping technology along with stereolithography method. Jehng [2] studied the parametric conjugate tooth profiles of bevel gear sets and derived the general profile equations, meshing constraint equations and non-undercut

condition equations. He also constructed gear geometric solid model for identifying the contours of meshing situations of the gear mechanism.

Kuo [6] derived the bevel gear with circular-arc tooth profiles by using general theorem of conjugate surfaces, coordinate transformation, constrained meshing equation, and spherical trigonometry. He discussed interference by applying the phase lead-lag concept while circular arc curve is moving on the spherical cross section and suggested the ideal conditions to avoid its occurrence. He also constructed a 3D model and verified the transmission ability. Later then, the proposed design parameters are modified by Hsieh [7] to develop bevel gear set with spiral point contact path. This improvement makes it possible to manufacture the newly developed bevel gears in a simple milling or/and grinding process with circular cutting edges. He proposed a method for checking the gear interference. He also constructed 3D solid models of the bevel gear with circular-arc tooth profiles as well as the grinding wheel.

Tsai and Hsu [8] assumed that the location of contact point projected on the pitch line is a linear function of the angular position of pinion; the existing meshing constraint equation of the general bevel gear sets has been degenerated into a special case of point-contact bevel gear sets with elliptic paths. They constructed the mathematical models of tooth surfaces by torus surface. Duan et al. [9] proposed loxodromic-type normal circular arc spiral bevel gear as an application of the circular arc tooth profile. They developed a mathematical model for the tooth alignment curve and a computational flow at the design stage to enable the generation of the tooth surface.

Wang et al. [10] performed a comprehensive literature review regarding the mathematical modelling of Spiral bevel gears. The methods of building mathematical models such as the matrix

method, the vector method and the geometry method, are illustrated, compared and summarized in detail. Also, the research history and applications of each method of building a mathematical model of spiral bevel gears are presented.

To our knowledge, there is no work has been done on studying spiral bevel gears with circular arc tooth profile for increasing its load carrying capacity while having the same size and material of the gear through modifying the tooth profile to circular arc.

1.2 Aim of Work

The aim of this work is to study spiral bevel gears with circular arc tooth profile for both manufacturing systems; Gleason and Klingelnberg. This will be accomplished through solving the meshing constraint equation of motion using the proposed assumptions, then performing the mathematical and solid modelling of tooth profile. The validity of these models is then checked. This will be done using software packages of MATLAB and CATIA.

2. Mathematical Modelling

The general kinematic relation between a pair of gears having two non-parallel and non-intersecting axes is shown in Fig.4.

According to screw theory, there must be a pitch line (instantaneous screw axis) on the plane constructed by the two shaft axes [8].

The value of relative velocity between pinion and gear for any point on this pitch line is zero. The angular parameter of this pitch line is termed δ which can be calculated from:

$$\delta = \tan^{-1} \left(\frac{\sin \Sigma}{m_G + \cos \Sigma} \right) \quad (1)$$

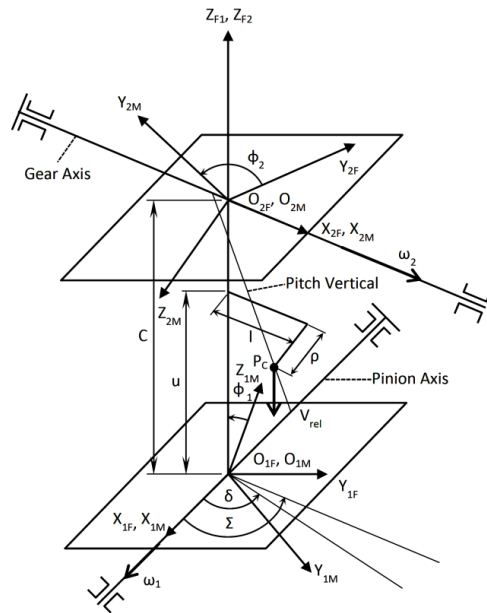

Figure 4 – Spatial relationships for gear sets. [1, 2, 5]

This angle, δ , is the pitch cone angle for the pinion. For the gear, pitch cone angle value would be $(\Sigma - \delta)$. Considering that the angular velocity of pinion is ω_1 and for gear ω_2 , then gear ratio (m_G) can be calculated as $m_G = \omega_1/\omega_2$.

Given that the pressure angle α is considered the angular parameter of the N plane (the plane containing both pitch line L and contact point P_c) [5] so that it is the angle included between the N plane and the plane of the two shaft axes, Fig.5.

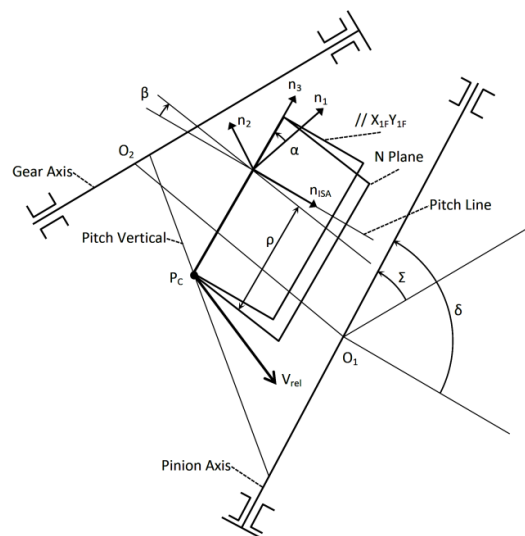

Figure 5 – N Plane and Instantaneous Screw Axis (ISA). [1, 2, 5]

2.1 Meshing Constraint Equation

The partial differential equation that is the constraint for the parametric conjugate tooth profile for bevel gears with intersecting axes was deduces as:

$$-\frac{\partial \rho}{\partial \phi_1} + \rho \sin \alpha \sin \delta \frac{\partial \rho}{\partial l} + l \sin \alpha \sin \delta = 0 \quad (2)$$

This equation is a first order quasi-linear partial differential equation. It is very difficult to solve this type. So, various trials, assumptions and simplifications are made seeking a solution for it.

A further simplification of this equation can be done by considering that both ρ and l are mutually orthogonal, Fig.4, so they are always independent at any contacting instant ($\partial \rho / \partial l = 0$). This assumption simplifies meshing constraint equation to:

$$-\frac{\partial \rho}{\partial \phi_1} + l \sin \alpha \sin \delta = 0 \quad (3)$$

Assuming that the contact type is a point contact such that both ρ and l are functions of ϕ_1 , the equation is then degenerated to an ordinary differential equation as:

$$-\frac{d\rho(\phi_1)}{d\phi_1} + l(\phi_1) \sin \alpha \sin \delta = 0 \quad (4)$$

Setting the value of $l(\phi_1)$ to [8]:

$$l(\phi_1) = a\phi_1 + b \quad (5)$$

$$a = \frac{l_f - l_i}{\phi_{1f} - \phi_{1i}} \quad \& \quad b = l_i$$

Where ϕ_{1i} , l_i and ρ_i are the initial values of ϕ_1 , l and ρ , and ϕ_{1f} and l_f are the final values of parameters ϕ_1 and l .

Using MATLAB toolboxes to solve the equation after setting the initial boundary conditions, the following solution results:

$$\rho(\phi_1) = \phi_1 \times \sin \alpha \sin \delta \times (2b + a\phi_1) / 2 \quad (6)$$

2.2 Contact Path

The meshing trajectory for bevel gears with intersecting axes can be

described through the parametric contact path equations:

$$r_1 = \begin{bmatrix} l \cos \delta - \rho \cos \alpha \sin \delta \\ (l \sin \delta + \rho \cos \alpha \cos \delta) \cos \phi_1 + \rho \sin \alpha \sin \phi_1 \\ -(l \sin \delta + \rho \cos \alpha \cos \delta) \sin \phi_1 + \rho \sin \alpha \cos \phi_1 \\ 1 \end{bmatrix} \quad (7)$$

$$r_2 = \begin{bmatrix} l \cos(\delta - \Sigma) - \rho \cos \alpha \sin(\delta - \Sigma) \\ (l \sin(\delta - \Sigma) + \rho \cos \alpha \cos(\delta - \Sigma)) \cos \phi_2 + \rho \sin \alpha \sin \phi_2 \\ -(l \sin(\delta - \Sigma) + \rho \cos \alpha \cos(\delta - \Sigma)) \sin \phi_2 + \rho \sin \alpha \cos \phi_2 \\ 1 \end{bmatrix} \quad (8)$$

Where $r_1, 2$ are the position vectors of contact path for the pinion and gear tooth respectively.

2.3 Spherical Geometry Modelling

To describe the spherical geometry of bevel gears with intersecting axes, assume L_1 is pinion axis, L_2 is gear axis, and Σ is the angle between the two shafts, Fig.6.

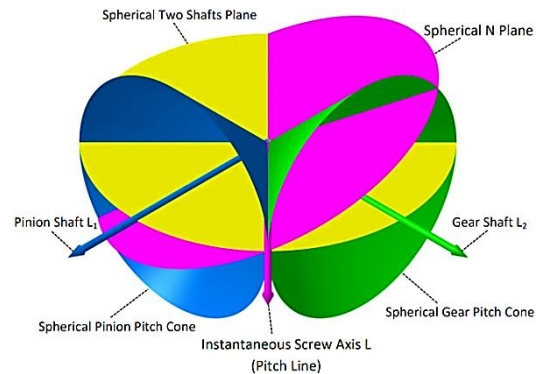

Figure 6 – Spherical bevel gear set with intersecting axis [7].

Consider $S_{1F} (X_{1F}, Y_{1F}, Z_{1F})$ is the coordinate system of the fixed frame of the pinion; $S_{1M} (X_{1M}, Y_{1M}, Z_{1M})$ is the coordinate system movable with the pinion. Similarly, $S_{2F} (X_{2F}, Y_{2F}, Z_{2F})$ and $S_{2M} (X_{2M}, Y_{2M}, Z_{2M})$ are the fixed and movable coordinate systems for the gear. In these coordinate systems, L_1, X_{1F} , and X_{1M} are collinear. Similarly, L_2, X_{2F} , and X_{2M} are collinear. All these coordinate systems are represented in Fig.7.

In order to obtain the circular arc tooth profile, the concept of coordinate transformation is going to be used. Consider S_{ISA} (X_{ISA} , Y_{ISA} , Z_{ISA}) is the coordinate system associated with the instantaneous screw axis (pitch line) where $X_{ISA}Y_{ISA}$ plane coincide with L_1L_2 plane. S_{1T} (X_{1T} , Y_{1T} , Z_{1T}) and S_{2T} (X_{2T} , Y_{2T} , Z_{2T}) are the two coordinate systems associated with pinion and gear teeth respectively. Screw axis L is collinear with both X_{1T} and X_{ISA} . Both $X_{1T}Y_{1T}$ plane and $X_{2T}Y_{2T}$ coincide with the N plane.

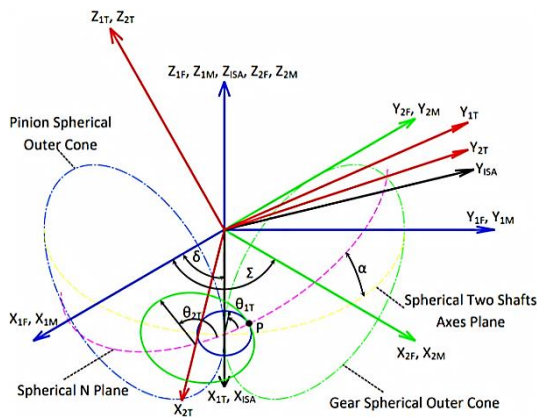

Figure (7) – Various coordinate systems [6].

In the tooth profile mathematical modelling process, the two main manufacturing systems will be considered; conical tooth profile for Gleason manufacturing system and cylindrical tooth profile for Klingelnberg manufacturing system.

First, Conical Tooth:

For bevel gears with conical tooth, profile can be modelled for pinion and gear as:

$$r_{1C} = \text{Rotation}(Z_{ISA}, \delta) \times \text{Rotation}(X_{1T}, \alpha) \times r_{1CT} \quad (9)$$

$$r_{2C} = \text{Rotation}(Z_{ISA}, \Sigma - \delta) \times \text{Rotation}(X_{1T}, \alpha) \times \text{Rotation}(Z_{2T}, \lambda_2 - \lambda_1) \times r_{2CT} \quad (10)$$

This can be represented through matrix transformation through:

$$r_{1C} = M_{S_{ISA} \rightarrow S_{1F}} \times M_{S_{1T} \rightarrow S_{ISA}} \times r_{1CT} \quad (9')$$

$$r_{2C} = M_{S_{ISA} \rightarrow S_{2F}} \times M_{S_{1T} \rightarrow S_{ISA}} \times M_{S_{2T} \rightarrow S_{1T}} \times r_{2CT} \quad (10')$$

Where $r_{1, 2C}$ are conical tooth profiles in $S_{1, 2F}$ coordinate systems and $r_{1, 2CT}$ are conical tooth profiles in $S_{1, 2T}$ coordinate systems.

The conical tooth profile can be represented in $S_{1, 2T}$ as:

$$r_{1CT} = \begin{bmatrix} r \cos \lambda_1 \\ r \sin \lambda_1 \cos \theta_{1CT} \\ r \sin \lambda_1 \sin \theta_{1CT} \end{bmatrix} \quad (11)$$

$$r_{2CT} = \begin{bmatrix} r \cos \lambda_2 \\ r \sin \lambda_2 \cos \theta_{2CT} \\ r \sin \lambda_2 \sin \theta_{2CT} \end{bmatrix} \quad (12)$$

The transformation matrices can be represented as:

$$M_{S_{ISA} \rightarrow S_{1F}} = \begin{bmatrix} \cos \delta & -\sin \delta & 0 \\ \sin \delta & \cos \delta & 0 \\ 0 & 0 & 1 \end{bmatrix} \quad (13)$$

$$M_{S_{1T} \rightarrow S_{ISA}} = \begin{bmatrix} 1 & 0 & 0 \\ 0 & \cos \alpha & -\sin \alpha \\ 0 & \sin \alpha & \cos \alpha \end{bmatrix} \quad (14)$$

$$M_{S_{ISA} \rightarrow S_{2F}} = \begin{bmatrix} \cos(\Sigma - \delta) & \sin(\Sigma - \delta) & 0 \\ -\sin(\Sigma - \delta) & \cos(\Sigma - \delta) & 0 \\ 0 & 0 & 1 \end{bmatrix} \quad (15)$$

$$M_{S_{2T} \rightarrow S_{1T}} = \begin{bmatrix} \cos(\lambda_2 - \lambda_1) & \sin(\lambda_2 - \lambda_1) & 0 \\ -\sin(\lambda_2 - \lambda_1) & \cos(\lambda_2 - \lambda_1) & 0 \\ 0 & 0 & 1 \end{bmatrix} \quad (16)$$

For the tooth profile along face width:

$$r_{1CL} = \begin{bmatrix} 1 & 0 & 0 \\ 0 & \cos \phi_1 & \sin \phi_1 \\ 0 & -\sin \phi_1 & \cos \phi_1 \end{bmatrix} \times r_{1C} \quad (17)$$

$$r_{2CL} = \begin{bmatrix} 1 & 0 & 0 \\ 0 & \cos \phi_2 & \sin \phi_2 \\ 0 & -\sin \phi_2 & \cos \phi_2 \end{bmatrix} \times r_{2C} \quad (18)$$

Where $r_{1, 2CL}$ are conical tooth profiles in $S_{1, 2M}$ coordinate systems.

Second, Cylindrical Tooth:

For bevel gears with cylindrical tooth profile, it can be modelled for both pinion and gear through:

$$r_{1Cy} = \text{Rotation}(Z_{ISA}, \delta) \times \text{Rotation} \quad (19)$$

$$\begin{aligned} & (X_{IT}, \alpha) \times r_{1CyT} \\ r_{2Cy} &= \text{Rotation} (Z_{ISA}, \Sigma-\delta) \times \text{Rotation} \\ & (X_{IT}, \alpha) \times r_{2CyT} \end{aligned} \quad (20)$$

This can be represented through matrix transformation through:

$$r_{1Cy} = M_{S_{ISA} \rightarrow S_{IF}} \times M_{S_{IT} \rightarrow S_{ISA}} \times r_{1CyT} \quad (19')$$

$$r_{2Cy} = M_{S_{ISA} \rightarrow S_{2F}} \times M_{S_{IT} \rightarrow S_{ISA}} \times r_{2CyT} \quad (20')$$

Where $r_{1, 2Cy}$ are cylindrical tooth profiles in $S_{1, 2F}$ coordinate system and $r_{1, 2CyT}$ is cylindrical tooth profiles in $S_{1, 2T}$ coordinate systems.

The cylindrical tooth profile can be represented in $S_{1, 2T}$ as:

$$r_{1CyT} = \begin{bmatrix} r \cos \lambda \\ r \sin \lambda \cos \theta_{1CT} \\ r \sin \lambda \sin \theta_{1CT} \end{bmatrix} \quad (21)$$

$$r_{2CyT} = \begin{bmatrix} r \cos \lambda \\ r \sin \lambda \cos \theta_{2CT} \\ r \sin \lambda \sin \theta_{2CT} \end{bmatrix} \quad (22)$$

Where λ Included angle between pitch line and contact point so that $\sin \lambda = r_{Cy}/r$, and $r_{Cy1, 2}$ are tooth cylinder radius for pinion and gear respectively.

For the tooth profile along face width:

$$r_{1CyL} = \begin{bmatrix} 1 & 0 & 0 \\ 0 & \cos \phi_1 & \sin \phi_1 \\ 0 & -\sin \phi_1 & \cos \phi_1 \end{bmatrix} \times r_{1Cy} \quad (23)$$

$$r_{2CyL} = \begin{bmatrix} 1 & 0 & 0 \\ 0 & \cos \phi_2 & \sin \phi_2 \\ 0 & -\sin \phi_2 & \cos \phi_2 \end{bmatrix} \times r_{2Cy} \quad (24)$$

Where $r_{1, 2CyL}$ are cylindrical tooth profiles in $S_{1, 2M}$ coordinate systems.

2.4 Flow Chart

The flowchart, illustrated in Fig.8, is divided into four main steps. The first step is for mathematical modelling, while the second step is for solid modelling. In the third step, checking interference is performed. The last step is performing the working drawing of gears.

For the mathematical modelling step, it is performed using MATLAB software. First, we should enter the values of the design parameters. The different values considered here for these parameters are:

Shaft Angle = 60° 90° 120°

Module [mm] = 4 6 8

Pinion Teeth = 20 30 40

Gear Ratio = 2 4

Pressure Angle = 25°

Face Contact Ratio = 1.25 1.5 1.75

Face Width = Cone Distance / 3 /4

These values are going to be used in calculation of basic geometry of bevel gears and in solving the meshing constraint equation. At the end of this step, both points representing contact path and tooth profiles are saved in an Excel Spreadsheet.

For solid modelling step, it is going to be performed using CATIA software package.

For the contact path points, they are modelled and connected together with a curved spline. Furthermore the points of tooth profile are connected with a circular spline; all the splines are connected together with a multi-section surface.

After solid modeling of both pinion and gear, a dynamic meshing simulation is performed in CATIA to make sure that there is no interference between pinion and gear teeth. If the gear pair is interference free, then a complete working drawing is performed for both pinion and gear.

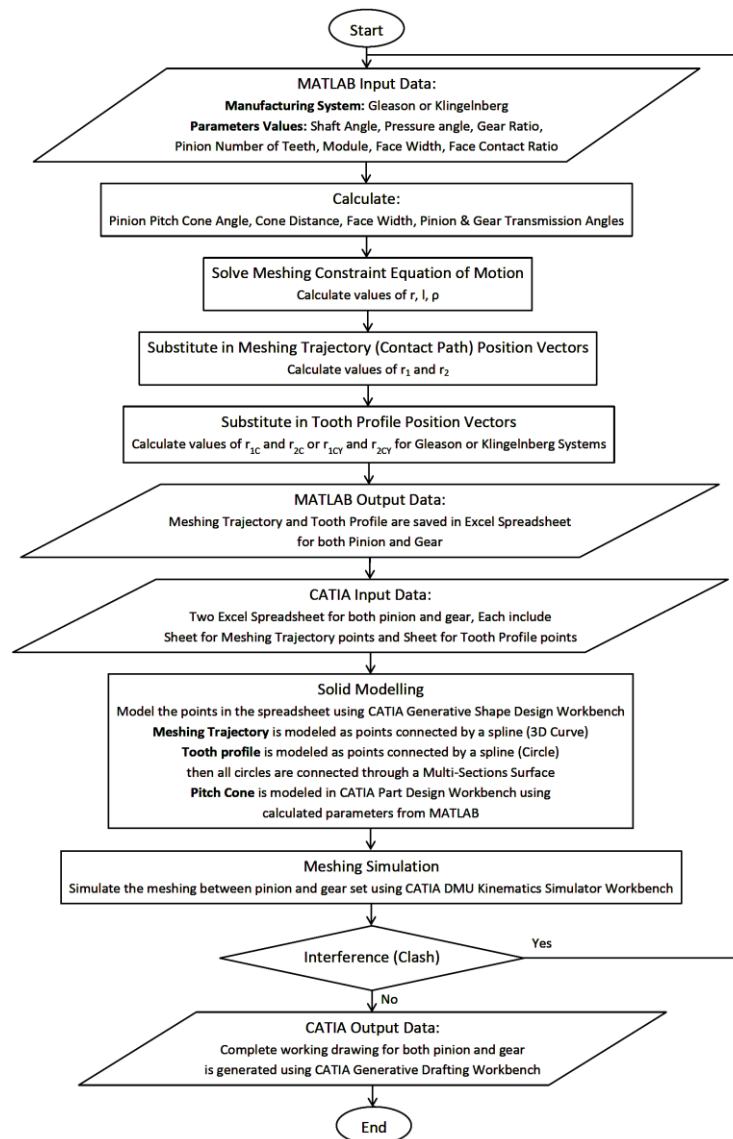

Figure 8 – Flow Chart

3. Solid Modelling

To validate the mathematical model proposed, various trials using different values of design parameters is performed. Both manufacturing systems, Gleason and Klingelberg, are included in these trials.

Conical and Cylindrical Tooth Sample Trial Parameters Values	
Shaft Angle	90°
Gear Ratio	2
Pinion Number of Teeth	20
Face Contact Ratio	1.5
Module	6mm
Face Width	Cone Distance/3

Fig.9 shows the meshing trajectories of both pinion and gear while assembled together for a Gleason system. Fig.10 shows the circular tooth profiles of a single pinion tooth along face width with an enlarged detailed view showing these circular profiles. Fig.11 shows a solid model for a pinion and gear assembled together.

Similarly, Fig.12 shows the meshing trajectories of both pinion and gear while assembled together for a Klingelberg system. Fig.13 shows the circular tooth profiles of a single gear tooth along face width with an enlarged detailed view

showing these circular profiles. Fig.14 shows a solid model for a pinion and gear assembled together.

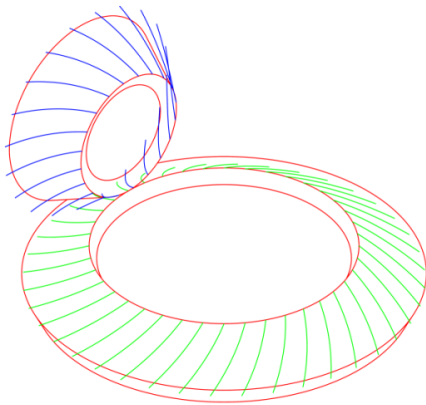

Figure 9 – Conical Tooth, Meshing trajectories of a gear pair.

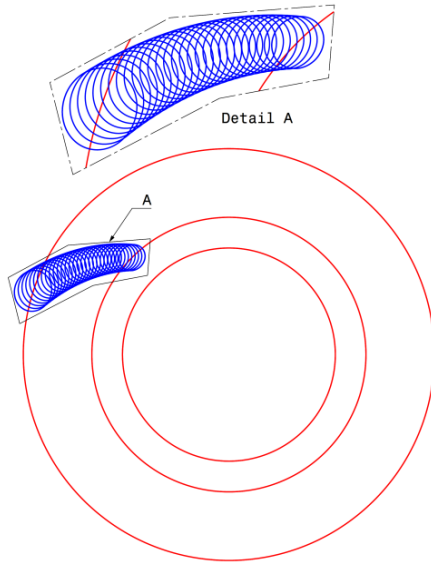

Figure 10 – Conical Tooth, Detailed view of tooth profile for pinion

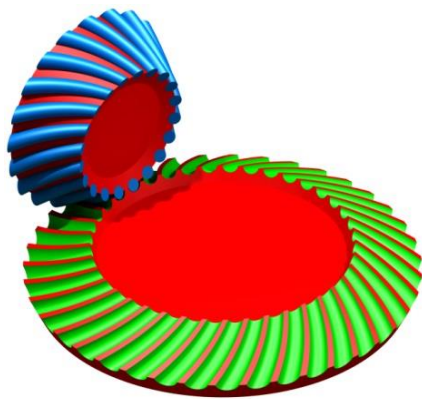

Figure 11 – Conical Tooth, Gear pair solid model.

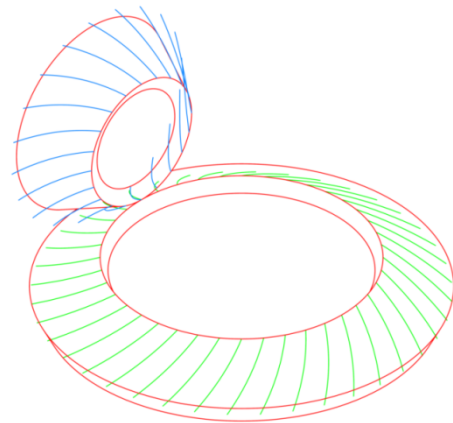

Figure 12 – Cylindrical Tooth, Meshing trajectories of a gear pair.

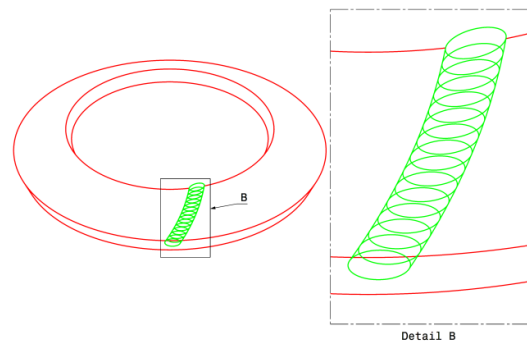

Figure 13 – Cylindrical Tooth, Detailed view of tooth profile for gear

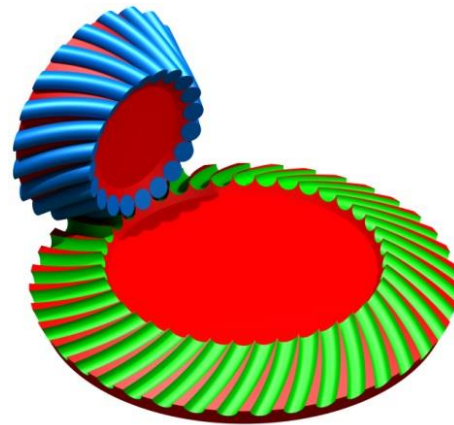

Figure 14 – Cylindrical Tooth, Gear pair solid model.

4. Results and Discussion

Several trials have been carried out to validate the mathematical model proposed in this paper. In these trials, it has been considered that there are several design parameters included in the

calculation of spiral bevel gear geometry. Also several values of these different design parameters have been used in the trials to ensure the mathematical model is valid for all design cases.

Fig. 10 and Fig. 13 showed the circular arc tooth profiles for pinion convex tooth and gear concave tooth respectively. These profiles form the tooth surface which is considered to be the cutter blade spatial trajectory to manufacture the tooth.

It has been considered in the interference check step that it is to be performed after solid modelling step using meshing simulation of 3D CAD software, CATIA, to visually detect if there is any interference (named *Clashes* in CATIA). A sample for interference check results of CATIA is shown in Fig.15.

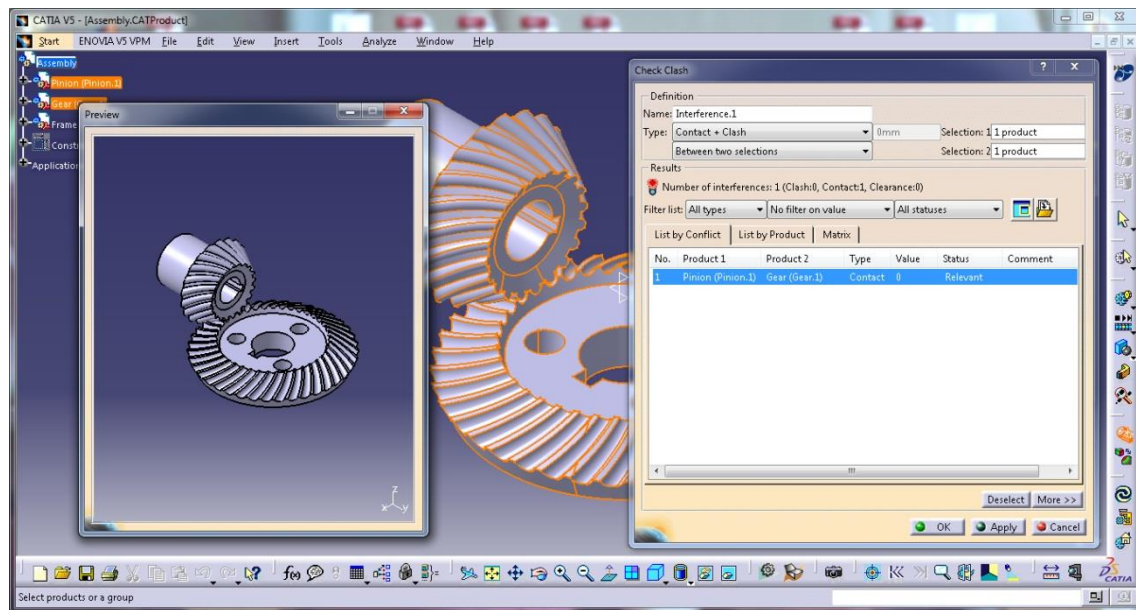

Figure 15 – Interference check results for one of performed trials.

5. Conclusion

It can be concluded that:

1. The proposed mathematical model is valid to describe spiral bevel gear geometry for both manufacturing systems; Gleason and Klingelnberg.
2. The solid modelled gears, for both manufacturing systems; Gleason and Klingelnberg, can have a dynamic simulation of rotational motion without interference at any instant.
3. The solid modelling has validated the no interference occurrence, for both manufacturing systems; Gleason and Klingelnberg, whatever was value of design parameters, namely: Two shafts angle, Module, Pinion number of teeth,

Gear ratio, Pressure Angle, Face Contact Ratio, Face Width.

4. Spiral bevel gears with circular arc tooth profile, for both manufacturing systems; Gleason and Klingelnberg, are applicable for being used as power transmission elements.
5. The proposed mathematical model of the gears tooth surface is considered the spatial trajectory of the gear cutter blade that can be used to manufacture them.

Acknowledgments

Dedicated to our families for their sincere care, help, patience, and encouragement.

References

- [1] Ying-Chien Tsai, Wern-Kueir Jehng, 1999, Rapid prototyping and manufacturing technology applied to the forming of spherical gear sets with skew axes, *Journal of Materials Processing Technology*, Volume 95, Issues 1–3, Pages 169–179.
- [2] Wern-Kueir Jehng, 2002, Computer solid modeling technologies applied to develop and form mathematical parametric tooth profiles of bevel gear and skew gear sets, *Journal of Materials Processing Technology*, Volume 122, Issues 2–3, Pages 160–172.
- [3] American National Standards Institute, American Gear Manufacturers Association, 2008, “American National Standard: Bevel and Hypoid Gear Geometry (ANSI/AGMA ISO 23509-A08)”, American Gear Manufacturers Association.
- [4] N. Chironis, 1962, Design of Novikov gears, *Product Engineering*.
- [5] Ying-Chien Tsai, Li-Min Sung, 1993, A Kinematic Study for Gear Sets with Skew Axes, *Journal of Applied Mechanisms and Robotics*, Volume 1, Issue 1, Pages 36-44.
- [6] Hsiu-Ming Kuo, 2001, A Study on the Bevel Gear with Circular-Arc Tooth Profiles (M.Sc. Thesis).
- [7] Ming-Lung Hsieh, 2003, A Design on the Bevel Gear with Circular-Tooth Profiles for Manufacturing (M.Sc. Thesis).
- [8] Ying-Chien Tsai, Wei-Yi Hsu, 2008, The study on the design of spiral bevel gear sets with circular-arc contact paths and tooth profiles, *Mechanism and Machine Theory*, Volume 43, Issue 9, Pages 1158–1174.
- [9] Zhenyun DUAN, Houjun CHEN, Zhilan JU, Jian LIU, 2012, Mathematical model and manufacture programming of loxodromic-type normal circular-arc spiral bevel gear, *Frontiers of Mechanical Engineering*, Volume 7, Issue 3, Pages 312-321.
- [10] Jixin Wang, Long Kong, Bangcai Liu, Xinpeng Hu, Xiangjun Yu, Weikang Kong, 2014, The Mathematical Model of Spiral Bevel Gears - A Review, *Journal of Mechanical Engineering*, Volume 60, Issue 2, Pages 93-105.