

6-11-2020

## Transient Stability Analysis of DFIGS Using Eigenvalues Analysis.

Mahmoud Abdelbacky

*a master's degree program in Electric Engineering Dept., Faculty of engineering, Mansoura Univ., Egypt, engmahmoudhebish2020@gmail.com*

Ahmed Hatata

*associated professor in Electric Engineering Dept., Faculty of engineering, Mansoura Univ., Egypt, a\_hatata@mans.edu.eg*

Sobhy Abdelkader

*professor in Electric Engineering Dept., Faculty of engineering, Mansoura Univ., Egypt, sakader@mans.edu.eg*

Follow this and additional works at: <https://mej.researchcommons.org/home>

---

### Recommended Citation

Abdelbacky, Mahmoud; Hatata, Ahmed; and Abdelkader, Sobhy (2020) "Transient Stability Analysis of DFIGS Using Eigenvalues Analysis." *Mansoura Engineering Journal*: Vol. 44 : Iss. 4 , Article 6. Available at: <https://doi.org/10.21608/bfemu.2020.95009>

This Original Study is brought to you for free and open access by Mansoura Engineering Journal. It has been accepted for inclusion in Mansoura Engineering Journal by an authorized editor of Mansoura Engineering Journal. For more information, please contact [mej@mans.edu.eg](mailto:mej@mans.edu.eg).



# Transient Stability Analysis of DFIGS Using Eigenvalues Analysis

## (تحليل الاستقرار العابر للمولدات التأثيرية مزدوجة التغذية باستخدام تحليل القيم الذاتية)

M. M. Abdelbacky, A. Y. Hatata and S. M. Abdelkader

### KEYWORDS:

*Doubly fed induction generators (DFIGs), eigenvalue analysis, phasor measurement unit (PMU), critical clearing time index, center of inertia (COI).*

**المخلص العربي:** نظرا لزياده وجود وانتشار طاقه الرياح في شبكات الطاقه الكهربيه والذي أدى إلى التأثير على إتران وسلوك هذه الشبكات. وبالتالي أصبح من الضروري معرفه تأثير المولدات التأثيرية مزدوجه التغذية (DFIGs) على إتران النظام. في هذا البحث تم عمل تحليل وتقييم لهذا التأثير باستخدام ال (critical center of inertia clearing time index and eigenvalues analysis). أيضا تم الإستعانه بال (technique) لدراسه هذا التأثير على سلوك النظام. كما تم عمل محاكاة لمقارنه أداء النظام في حاله وجود وعدم وجود المولدات التأثيرية مزدوجه التغذية أثناء حدوث الخطأ وبعد إزالة هذا الخطأ مباشرة. وأثبتت النتائج جدوى وفاعلية الحل المقدم في هذا البحث حيث أنه في حاله إستبدال المولدات التزامنيه بمولدات تأثيريه بنفس قيمة القدره الفعالة (active power) يحدث تحسن ملحوظ لل (transient stability) للنظام ويرجع هذا التحسن إلى إستطاعه المولدات التأثيرية مزدوجه التغذية على التغلب على الأخطاء التي تحدث في الشبكة بدون حدوث تغيير جسيم في خرج القدره الفعاله الخاصه بها وذلك بعد إزالة هذا الخطأ على عكس المولدات التزامنيه التي تتأثر بصورة ملحوظه بالأخطاء التي تحدث في الشبكة.

**Abstract—** The increasing penetration of the wind power generation into the electrical power system has led to increasing the unconventional generators into the system. The Doubly Fed Induction Generators (DFIGs) is the most common type utilized for the wind power generation. In this article, the impact of the DFIGs integration on the power system transient stability is analyzed and evaluated by using the index of the critical clearing time (CCT) and eigenvalue analysis. Moreover, the new Center of Inertia (COI) technique is used to study the effect of the integrated DFIGs on the power system transient behavior. The simulation studies are performed to compare the system transient performance with/without DFIGs integration during and after a severe grid fault. Also, they are executed to compare the transient

behavior of the power system with/without replacing the synchronous generators with DFIGs. The results show a significant improvement in the transient behavior is achieved by replacing some of the synchronous generators with DFIGs of the same capacity.

### I. INTRODUCTION

RENEWABLE energy sources like wind energy have become well-known all over the world as an effective way to get significant development in environmental and economic terms. The Doubly Fed Induction Generators (DFIGs) is the most common type applied for wind power generation. DFIG has become a progressive technology with important development. This is due to its good efficiency, low electronic devices ratings and low mechanical stresses on the wind turbines [1-3].

The concept of DFIG [1-2] is that the wound-rotor induction generator is connected to the grid at the stator terminals. While the rotor terminals are connected through a partially rated Variable Frequency AC/DC/AC Converter (VFC). The VFC consists of a Grid-Side Converter (GSC) and Rotor Side Converter (RSC) connected back-to-back by a DC-link capacitor. As a result of using the converters in the

Received: 28 July, 2019 - Revised: 24 November, 2019 - Accepted: 8 December, 2019

Prof. Dr. S. M. Abdelkader is currently working as a professor in Electric Engineering Dept., Faculty of engineering, Mansoura Univ., Egypt. And also, He is working as a Head of Electrical Power Department, Faculty of engineering, Egypt-Japan Univ. of Science and Technology, Egypt, E-mail: sakader@mans.edu.eg).

Dr. A. Y. Hatata is currently working as an associated professor in Electric Engineering Dept., Faculty of engineering, Mansoura Univ., Egypt, E-mail: (a\_hatata@mans.edu.eg).

Eng. M. M. Abdelbacky is currently pursuing a master's degree program in Electric Engineering Dept., Faculty of engineering, Mansoura Univ., Egypt, E-mail: (engmahmoudhebish2020@gmail.com).

excitation system of the DFIGs, the dynamic response is fundamentally depended on the coordinated control plans of the converters. Therefore, they are totally different from the conventional synchronous generators [4-5].

The synchronous generators are the main component in the conventional power system, that affect the transient stability of the system. During the disturbance, the speed governor controls the frequency by adjusting the active power of the synchronous generator. So, it can maintain the stability of the power system. Nevertheless, the controllability of the synchronous generators controllers is limited by their operating conditions [3]. During large disturbances, the controllers of the synchronous generator probably don't have the ability to control their generators to return to the steady-state operating point. So, the synchronous generators lose the synchronization (or lose the angular stability) and tripped from the remaining part of the power system. Thus, additional contingencies may take place and have an impact on the overall system stability.

In DFIG, using the power electronic converter (i.e. VFC) can fetch some operation and control features. For example, the DFIG can effectively overcome the grid faults without causing any trouble in the system stability, if an appropriate uninterrupted operation technique and rapid control of the variable frequency converter are used. So, the DFIG may be prominent over the synchronous generator for maintaining the power grid stability during some severe grid disturbances [1, 5].

The impact of DFIG's integration on the synchronous generators' rotor dynamics using a two-generator connected to infinite bus system was introduced in [6]. Also, the DFIG effect on the system transient behavior was evaluated in [7]. It considered the variation of the different DFIG penetrations, structures of the network and Points of Common Coupling (PCC). Ref. [8] used the synchro-phasor measurements to determine the equivalent inertia of the power source (wind turbine / synchronous generators) for detecting the system angle instability with different wind power penetrations.

Different stability indices had been suggested to determine the system transient stability. Refs. [7-9] introduced the critical clearing time (CCT) of the fault as the most widespread flexible index. It is the maximum time which a disturbance can be applied without losing the stability of the system. In [9], the fault CCT of the modified IEEE 39-bus system which contains both DFIGs and synchronous generators was simulated. The results proved that the DFIGs improved the system transient stability. Ref. [10], calculated the transient stability index by using the largest angle variation of the synchronous generators. It was indicated that the impact of the DFIG on transient stability could be positive or negative. Furthermore, the multi-machine systems transient stability analysis was analyzed in [11-17], by using the Center Of Inertia (COI) of the system. It was characterized as a virtual dynamic position. The COI was calculated by using the average of the instantaneous rotor angle of all synchronous generators in the power system. The system COI was firstly introduced in [15]. Then it was used effectively to describe the

dynamic behaviors of the whole system and the generators coherent clusters [16]. Moreover, the COI based reference was also considered as an efficient index for the dynamic monitoring of the individual synchronous generator [17].

This paper studies the effect of the wind power integration on the transient stability of the power system. Substituting the conventional generators by DFIGs and adding DFIGs to the power system are both investigated in this paper. The stability of the system is calculated by using the eigenvalue analysis and the fault CCT index. The power system is simulated by using the power factory Digsilent program.

## II. ANALYSIS OF DFIG TRANSIENT BEHAVIOR

The comparing of the transient behavior of the integrated DFIGs and the conventional synchronous generators is considered so valuable, particularly when studying the effect of integrated DFIGs on transient stability of the power system. The acceleration/deceleration of the traditional synchronous generators occurs during the disturbance of the power system. This is due to the mismatch between the input mechanical power and the output electrical power. The changes in the electrical power output are occurred depending on the characteristic of power angle due to the rotor angle change [3-5]. The synchronous generator's inertia is used to damp the quick changes in rotor speed, electrical power output, and grid frequency oscillation. So, the strong relationship between the rotor speed, the system frequency and the power generation of synchronous generators is so clear.

On the other side, the quick and delicate excitations of the variable-frequency in the DFIGs rotor windings are done using the back-to-back converters. This makes the stator windings variables are within the grid angular speed with no respect to rotor speed changes. As a result, the integrated DFIGs electrical power outputs are decoupled with the rotor dynamics. So, rapid and flexible modulation can be performed during system disturbance. Thus, the integrated DFIGs provide no value to the power system inertia [18]. Moreover, the power angle characteristic is not present in the DFIGs excitation. Therefore, the "relative swing" and "rotor angle deviation" are not convenient for explaining the relationship between the synchronous generators and integrated DFIGs. So, in this study, it is proposed that the integrated DFIGs operate independently with no direct interactions with the other generators in the power system during the transient actions.

In the following sections, the mathematical models for the COI and the motion equation of the system in case of with/without the integration of DFIGs are discussed. Also, the effect of the DFIG integration on the system motion equation and the system behavior are studied.

## III. MATHEMATICAL MODELING

The center of rotor angles,  $\delta_C$ , and the center of rotor speeds,  $\omega_C$ , of the synchronous generators are defined by [8],

$$\delta_c = \frac{1}{H_{J,C}} \sum_{i=1}^n H_{J,i} \delta_i \quad (1)$$

$$\omega_c = \frac{1}{H_{J,C}} \sum_{i=1}^n H_{J,i} \omega_i \quad (2)$$

where:

$$H_{J,C} = \sum_{i=1}^n H_{J,i} \quad (3)$$

The system motion equation,  $p(\omega_c)$ , is defined by [19],

$$p(\omega_c) = \frac{1}{H_{J,C}} P_C \quad (4)$$

The system accelerating power,  $P_C$ , is defined by,

$$\begin{aligned} P_C &= P_{m,C} - P_{e,C} \\ &= \left( \sum_{i=1}^n P_{m,i} \right) - \left( \sum_{i=1}^n P_{e,i} \right) \end{aligned} \quad (5)$$

where  $\delta$  is the rotor angle,  $\omega$  is the rotor speed and  $H_J$  is the inertia constant. Subscript  $c$  denotes the variable of the system center of inertia,  $i$  indicates the variables of the  $i^{\text{th}}$  generator and  $n$  denotes the number of generators in the system.  $p$  is the differential operator.  $P_{m,i}$  is the mechanical power of the  $i^{\text{th}}$  generator and  $P_{e,i}$  is the electrical power of the  $i^{\text{th}}$  generator.

Thus; the motion equation of the system can be expressed by [19],

$$P(\omega_c) = \frac{1}{H_{J,C}} \left( \left( \sum_{i=1}^n P_{m,i} \right) - \left( \sum_{i=1}^n P_{e,i} \right) \right) \quad (6)$$

According to Eqs. (1) and (2), the  $i^{\text{th}}$  generator dynamics of the COI-based reference ( $\delta_{i,c}$  &  $\omega_{i,c}$ ) can be represented by [11],

$$\delta_{i,c} = \delta_i - \delta_c \quad (7)$$

$$\omega_{i,c} = \omega_i - \omega_c \quad (8)$$

The dynamic motion equation for each synchronous generator regarding the COI based reference,  $p(\omega_{c,i})$ , is defined as:

$$p(\omega_{c,i}) = \frac{1}{H_{J,i}} (P_{m,i} - P_{e,i}) - \frac{1}{H_{J,C}} \left( \left( \sum_{i=1}^n P_{m,i} \right) - \left( \sum_{i=1}^n P_{e,i} \right) \right) \quad (9)$$

From Eqs. (1) – (8), it is cleared that the concept of the COI is related to the power angle characteristics of synchronous generators and the mutual synchronization technique between synchronous generators.

The integrated DFIGs have no direct contribution in the consisting of system COI, but it may have an effect on the main factors that define the transient behaviors of system COI

and the transient behaviors of each synchronous generator. So, the dynamics of the system COI and the synchronous generators are considered and analyzed with the existing of the DFIGs.

The dynamic motion equation of the system with the existing of the DFIGs can be expressed by,

$$\begin{aligned} p(\omega'_c) &= \frac{1}{H'_{J,C}} (P'_{m,C} - P'_{e,C}) \\ &= \frac{1}{H'_{J,C}} \left( \left( \sum_{i=1}^n P'_{m,i} \right) - \left( \sum_{i=1}^n P'_{e,i} \right) \right) \end{aligned} \quad (10)$$

where superscript  $'$  indicates the variables with the existing of DFIGs.

The DFIG integration affects the coefficients and physical quantities in the dynamic motion Eq. (10); the inertia constant of the system, input mechanical power, and the output electrical power. The effect of the DFIG integration on these three parameters can be determined as follows:

#### A. System inertia constant ( $H_{J,C}$ )

The integrated DFIGs are considered as no-inertia to the system. So, in case of the insertion of DFIGs in the system without substituting any synchronous generators,  $H_{J,C}$  of the system would not be changed.

where:

$$H'_{J,C} = H_{J,C} \quad (11)$$

In case of insertion DFIGs in the system by substituting some synchronous generators, the  $H'_{J,C}$  should be described as follow:

$$H'_{J,C} = H_{J,C} - H_{J,\text{rep}} \quad (12)$$

where  $H_{J,\text{rep}}$  is the replaced synchronous generators inertia constant.

#### B. System total mechanical input power ( $P_{m,c}$ )

During the large disturbance, the speed governors of the DFIGs and the synchronous generators don't have the ability to adjust the input mechanical power rapidly. Thus, it is considered that the mechanical power is generally constant in the theoretical transient analysis as a simplification. So, the mechanical power of the DFIGs, synchronous generators and the system in this paper are also considered fixed during the large disturbances. The system mechanical power without DFIGs,  $P_{m,c}$ , and with DFIGs,  $P'_{m,c}$ , are defined by,

$$P_{m,C} = P_{e,C|0} = P_{\Sigma|0} \quad (13)$$

$$P'_{m,C} = P'_{\Sigma|0} - P_{m,\text{DFIG}} \quad (14)$$

where:

$$P_{\Sigma} = P_{\text{load},\Sigma} + P_{\text{loss},\Sigma} \quad (15)$$

where  $P_{load,\Sigma}$  and  $P_{loss,\Sigma}$  are the system total load and losses respectively.  $P'_\Sigma$  and  $P_\Sigma$  are the system total power demand in case of with and without connecting DFIGs in the system.  $P_{m,DFIG}$  is the input mechanical power of DFIGs in the system and the subscript |0| describes the pre-fault state variables.

### C. System total electrical output power ( $P_{e,C}$ )

The output power of each generator is a function of the time based on its state of operation. However, the total electrical output power of the generators permanently equal to the total power demand in the system. So, the system electrical power without the DFIGs,  $P_{e,C}$ , and the system electrical power with DFIGs,  $P'_{e,C}$ , are calculated by,

$$P_{e,C} = P_\Sigma \quad (16)$$

$$P'_{e,C} = P'_\Sigma - P_{e,DFIG} \quad (17)$$

where  $P_{e,DFIG}$  is the output electrical power of the DFIGs.

The voltage stability of the system is the main factor that affects the total power demand of the system. So, if the integrated DFIGs don't have much effect on the system transient voltage dynamic, the system total power demand with and without the existing of DFIGs in the system ( $P_\Sigma$  and  $P'_\Sigma$ ) can be considered as constants. Also, if the integration of the DFIG and the changes in transient voltage stability of the system affect clearly the network structures or the distribution of the reactive power, the  $P'_\Sigma$  dynamic responses can't be considered the same as  $P_\Sigma$ . Based on Eq. (17), the system electrical power with DFIGs is affected by the electrical power output of the integrated DFIGs. Furthermore, the dynamic response of the synchronous generators' electrical power output is different from the electrical power output of the DFIGs due to the different mechanisms of the excitation. So, if the integration of the DFIGs doesn't have much effect on the system total demand,  $P'_\Sigma$ , the electrical power output of the integrated DFIGs,  $P_{e,DFIG}$ , becomes the significant factor that used to determine the difference between  $P'_{e,C}$  and  $P_{e,C}$ .

The system inertia constant,  $H_{J,C}$ , is considered as an essential parameter in the power system, which is constant during the dynamic operations. If the wind speed is assumed to be constant during the transient disturbance, the system mechanical power,  $P_{m,C}$ , will also unchanged, as well; the system electrical power,  $P_{e,C}$ , varies with the time during the disturbance. However, the particular conditions for the integration of the DFIGs determine the impact of DFIGs integration on the three key factors ( $H_{J,C}$ ,  $P_{m,C}$ , and  $P_{e,C}$ ). Also, it determines the impact of changing these factors on system dynamics.

## IV. IMPACT OF DFIG'S INTEGRATION ON TRANSIENT STABILITY

In this section, the impact of the integrated doubly fed induction generator wind farms (DFIG-WF's) on the power system transient stability is discussed. It discusses the effect of the DFIG-WF's integration on the system dynamic motion. It

divided into two scenarios as follow:

- Scenario#1: with no synchronous generators replacing
- Scenario#2: with synchronous generators replacing

### A. With no synchronous generators' replacement

This section discusses how the integrated DFIG-WF's affect the dynamic motion of the system. In this scenario, the DFIG-WF's are integrated into the power system in parallel with some synchronous generators with no replacement of synchronous generators. The system power demand can be considered as a constant due to neglect the variations in the structure of the network and the system dynamic voltage stability.

Based on Eqs. (11) – (17), the changes in the three key factors ( $H_{J,C}$ ,  $P_{m,C}$ , and  $P_{e,C}$ ) which define the dynamic motion of the system are as follow:

$$P'_{m,C} = P_{m,C} - P_{m,DFIG} \quad (18)$$

$$P'_{e,C} = P_{e,C} - P_{e,DFIG} \quad (19)$$

According to Eqs. (4), (11), (18) and (19), the relation between the accelerating speeds of COI and the DFIG integration ( $p(\omega'_C) - p(\omega_C)$ ) can be expressed by,

$$\begin{aligned} p(\omega'_C) - p(\omega_C) &= \frac{1}{H'_{J,C}} (P'_{m,C} - P'_{e,C}) \\ &\quad - \frac{1}{H_{J,C}} (P_{m,C} - P_{e,C}) \\ &= \frac{1}{H_{J,C}} (P_{e,DFIG} - P_{m,DFIG}) \\ &= \frac{1}{H_{J,C}} (-\Delta P_{DFIG}) \end{aligned} \quad (20)$$

where  $\Delta P_{DFIG}$  is DFIGs' accelerating power. The difference in the system accelerating power can be written as:

$$\hat{P}_C - P_C = (-\Delta P_{DFIG}) \quad (21)$$

where  $\hat{P}_C$  is the COI accelerating power with DFIGs integration, and  $P_C$  is the COI accelerating power without DFIGs integration.

According to Eq. (20), when DFIGs are integrated without any synchronous generators substituting and the system inertia constant is not changed, the accelerating power of the integrated DFIG-WFs becomes the main factor which affects the dynamic motion of the system.

### B. With synchronous generators' replacement

In this section, some of the synchronous generators are substituted by DFIG-WFs with the same active power capacity. The impact of integrated the DFIG's on the system transient voltage stability is eliminated by supplying it with switched Static Var Compensator (SVC). The switched SVC controls the reactive power output according to the terminal voltage sags of the DFIG-WF's busbar [20]. So, the lack of the dynamic reactive power due to the synchronous generators

replacing is compensated by the SVC.

The changes in the three main parameters that determine the system's dynamic motion are described by Eqs. (12), (18) and (19). The system dynamic motion is affected by changing the accelerating power of the COI, in addition to the inertia constant of the COI.

According to Eqs. (4), (12), (18) and (19), the accelerating speeds of the COI in case of replacement the synchronous generator with DFIGs is determined by,

$$\begin{aligned} p(\omega'_c) &= \frac{1}{H_{J,C} - H_{J,rep}} [(P_{m,C} - P_{e,C}) - \Delta P_{DFIG}] \\ &= \frac{1}{H_{J,C} - H_{J,rep}} (\dot{P}_C) \end{aligned} \quad (22)$$

The dynamic motion of the system in case of synchronous generators replacement is affected by the variations in the accelerating power of COI, and the inertia constant of COI as illustrated in Eq. (22).

## V. SMALL SIGNAL STABILITY STUDY USING THE EIGENVALUE AND CCT INDICES

The system stability or instability can be discriminated by utilizing the Eigenvalues analysis. The non-oscillatory mode is related to the real Eigenvalues while the oscillatory mode is related to the complex Eigenvalues. The system is classified as a stable if the real part of all complex Eigenvalues is negative. While the system is classified as unstable if the real part of any complex Eigenvalue is positive [21]. The damping ratio is determined by using the complex Eigenvalues' real part. When the damping ratio is increased, the damping for the oscillation in the system will be increased. The oscillation frequency is determined from the complex Eigenvalues' imaginary part.

$$\lambda = \sigma + j\omega \quad (23)$$

where  $\lambda$  is the Eigenvalue complex pair and  $\sigma$  is the Eigenvalue real part which gives an indication to the degree of stability in the system.  $\omega$  is the Eigenvalue imaginary part which gives the information about the degree of oscillation in the system also, the oscillation frequency is determined from this part. The oscillation frequency,  $f$ , can be determined by [21];

$$f = \omega/2\pi \quad (24)$$

The damping ratio,  $\zeta$ , can be determined by,

$$\zeta = \frac{-\sigma}{\sqrt{\sigma^2 + \omega^2}} \quad (25)$$

The CCT index is used to determine the required protections characteristics of the power system.

## VI. PROPOSED TRANSIENT STABILITY ANALYSIS AND EVALUATION ALGORITHM

The transient stability of the power system is studied by using two indices; CCT and Eigenvalues analysis. This is done

to illustrate the difference between the behavior of the conventional synchronous generators and the DFIGs during and after severe disturbances. The proposed algorithm is performed to determine the improvement of the transient stability for the power system as follow,

- 1) Read the power system data; the rotor angle,  $\delta$ , the rotor speed,  $\omega$ , the inertia constant,  $H_J$ , the mechanical power,  $P_m$ , and the electrical power,  $P_e$ , of each synchronous generator in the system.
- 2) Determine the system motion equation by using the mathematical models of the COI constants, the rotor angles' center, and center of rotor speeds for all the synchronous generators in the power system.
- 3) Connect the DFIGs to the power system by using two scenarios; the first one by adding DFIGs in parallel with the synchronous generators and the second one by replacing the synchronous generators with the DFIGs with the same capacity.
- 4) In each scenario:
  - A. The system motion equation is determined in the case of existing the DFIGs.
  - B. Discuss the main factors which affect the motion equation of the system.
  - C. Calculate the COI accelerating power in case of existing the DFIGs (it is equal to the negative DFIGs' accelerating power).
  - D. Apply three-phase faults on a certain busbar of the power system with different clearing time to push the system to unstable conditions by using DigSilent simulation program.
  - E. Study the behavior of the system in case of with and without connecting DFIGs by using:
    - *CCT index.*
    - *Eigenvalues analysis.*
    - *Synchronous generators rotor angles during and after the fault.*
    - *Synchronous generators active power during and after the fault.*
    - *Synchronous generators rotor speeds during and after the fault.*
    - *The behavior of the DFIGs active power, accelerating power and terminal voltages.*
  - F. Compare the results in case of with and without connecting DFIGs by using the previous parameters and determine the improvement of the system transient stability.
- 4) Compare between the two scenarios and deciding which scenario is the best.

## VI. RESULTS AND DISCUSSIONS

The IEEE 39-bus system which contains 10 synchronous generators and 39 buses is the base case of the test system [22]. A modified IEEE 39-bus system which contains 10 synchronous generators, 17 DFIGs, and 39 buses are adopted for the following simulation studies, as shown in Figure 1. Generator, G2, is the reference generator for the system. So, it is the most influenced generator with the fault.

In this study, some assumptions are considered;

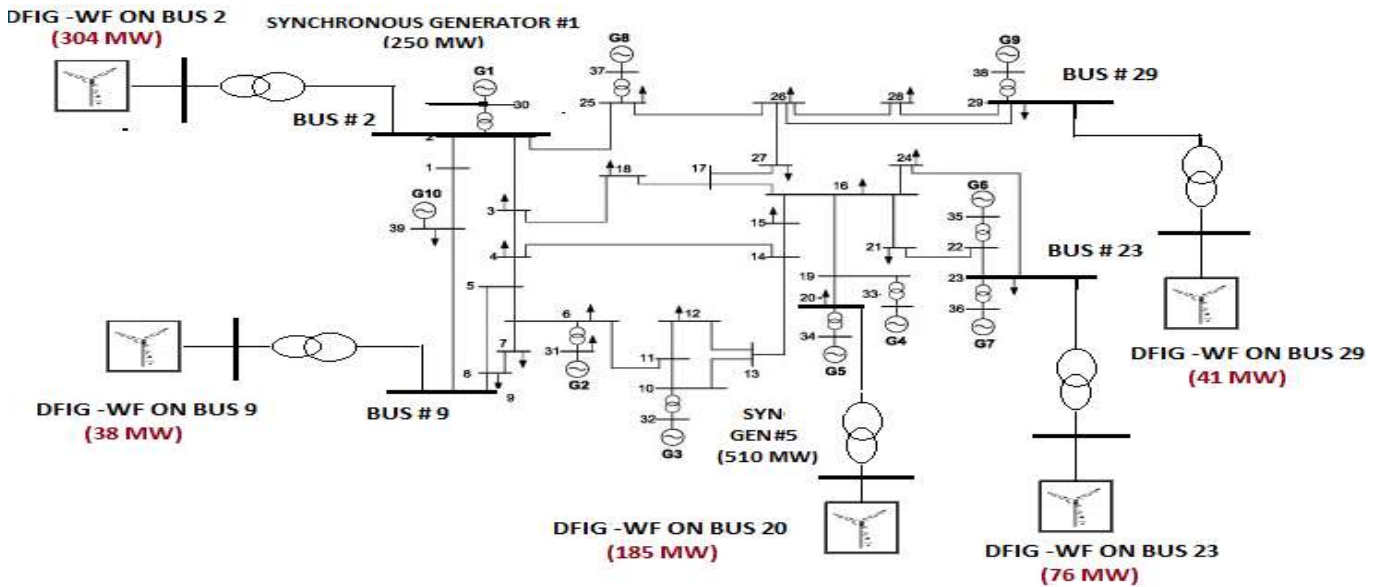

Fig. 1. Modified IEEE 39-bus study system

- The total power of loads remains constant in case of with and without the DFIG integration.
- The system is tested for severe contingency by applying cascaded disturbances or increasing the fault time on the system.
- Three-phase short circuit faults are applied at line 4-14 near bus 4 at 15.1sec.
- The faults are cleared by tripping line 4-14 at different times; 15.576sec, 15.598sec, and 15.928sec.
- The base-case which applied on the original system without DFIGs is considered as the reference for comparisons.

A. Scenario#1: with no synchronous generators' replacement

In this scenario, The DFIG-WFs are added into the power system in parallel with the synchronous generators (G1 at bus 2, G9 at bus 29, G7 at bus 23 and G5 at bus 20) with no replacement of the synchronous generators. The DFIG-WFs' rated capacity is 645 MW. So, the penetration percent of DFIGs in the system is 10.5 %. The total power demand of the system can be considered as fixed due to neglect the variations in the structure of the network and the dynamic responses of the system voltage stability.

A three-phase fault is applied on the transmission line 4-14 and it is cleared by removing this line. The fault clearing time is set to be 15.598sec (fault time = 0.498sec). Figure 2 illustrates the transient response of the synchronous generators' rotor angles without connecting the DFIGs. After the fault is cleared, all the synchronous generators' rotor angles are oscillated with high frequency and reached large values (+178° & -175°). So, all the synchronous generators loss their synchronism and the system become unstable.

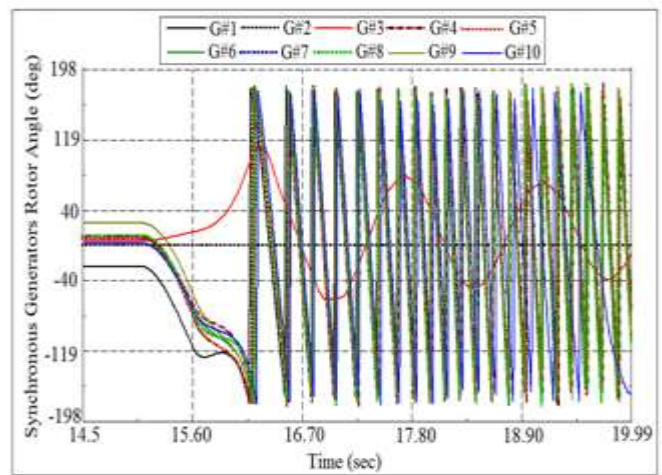

Fig.2. Synchronous generators' rotor angles –with no DFIGs

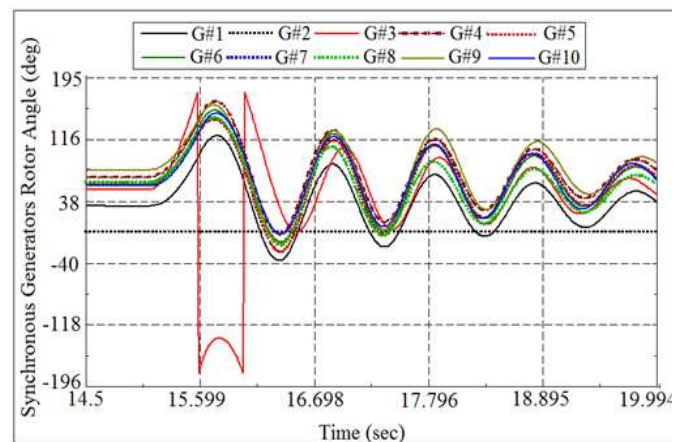

Fig.3. Synchronous generators' rotor angles – in case of connecting DFIGs

Figure 3 illustrates the dynamic response of synchronous generators' rotor angles in case of connected the DFIGs with a

rated capacity of 645 MW. By connecting the DFIGs in parallel with the synchronous generators, all the synchronous

generators oscillate with low frequency except G3 reaches  $176^\circ$ . But the values of the synchronous generators' rotor angles reach the steady-state values ( $75^\circ$  for G9 and  $38^\circ$  for G1) in a small time and the system returns to the stability.

Figure 4 shows the dynamic response of the synchronous generators' active power without connecting the DFIGs. It is cleared that, large fluctuations are occurred for the megawatt values of synchronous generator, G10, (its value reaches 1239 MW which above its normal load by 34%), G2 (its value reaches 1242 MW which above its normal load by 108%) and G3 (its value reaches 1236 MW which above its normal load by 81.7%). This leads to instability of the system.

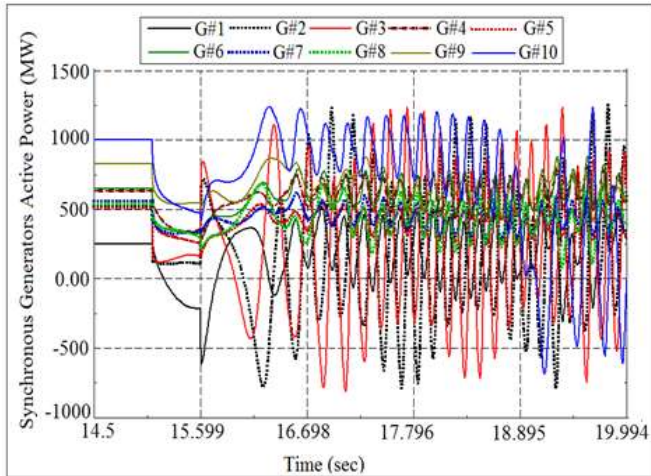

Fig. 4. Synchronous generators' active power –with no DFIGs

Figure 5 shows the dynamic response of synchronous generators' active power in case of connecting the DFIGs with a rated capacity of 645 MW. By connecting the DFIGs in parallel with the synchronous generators, the fluctuations that occurred for the megawatt values of synchronous generators G1, G2, G3, and G10 are decreased. After the fault is cleared, G3 reaches 1018 MW which above its normal load by 49.7%. Also, the G10 reaches 1228 MW which above its normal load by 22.8%. So, the megawatt values of all synchronous generators reach the steady-state values in a small time and the system returns to the stability.

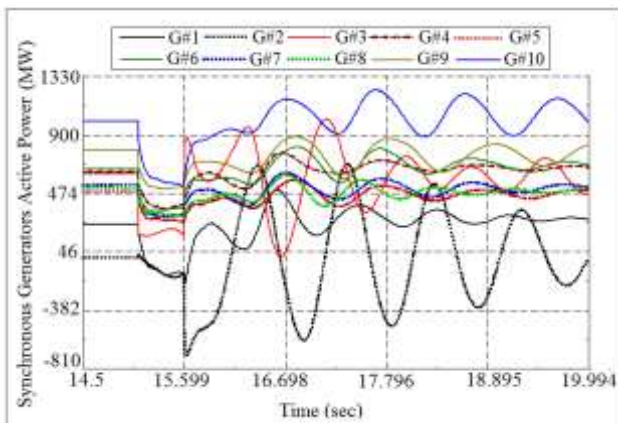

Fig. 5. Synchronous generators' active power – in case of connecting DFIGs

Figure 6 illustrates the transient response for the synchronous generators' rotor speed without connecting the DFIGs. It shows the accelerating power and speed of each synchronous generator during and after the fault. It's cleared that the synchronous generators G2, G3 and G10 loss their synchronism due to their small distances from the severe fault. Since their rotor speed values reach the trip values (69.8Hz or 4187r.p.m for G2 and 69.54Hz or 4172 r.p.m for G3).

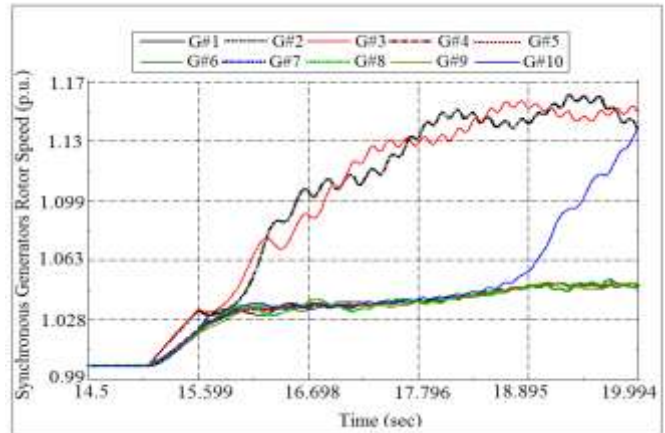

Fig. 6. Synchronous generators' rotor speed –with no DFIGs

Figure 7 illustrates the transient response of synchronous generators' rotor speed with connecting the DFIGs with the rated capacity of 645 MW. By connecting the DFIGs in parallel with the synchronous generators, all the synchronous generators reach the steady-state speed values after fault clearing (1.016 p.u or 60.96 Hz or 3657R.P.M).

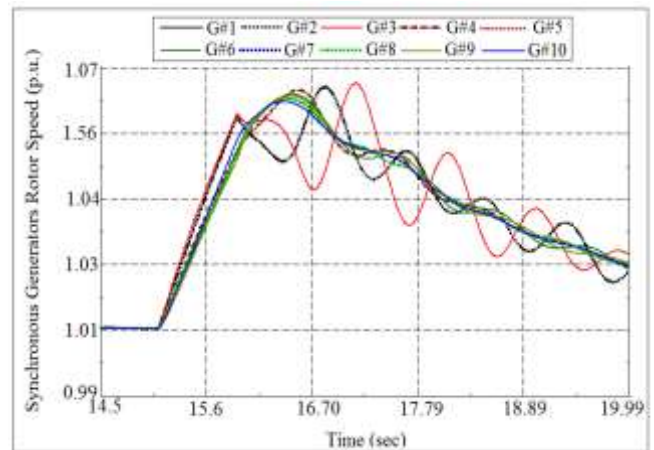

Fig. 7. Synchronous generators' rotor speed – in case of connecting DFIGs

Figures 8 and 9 illustrate the transient response of the speed and electrical power of the DFIG-WFs with the rated capacity of 645MW respectively. It is cleared that when DFIG-WFs are connected to the system, the absolute value of the DFIG-WFs' accelerating power increases during and after the period of fault as shown in Figure 8. During the fault, the accelerating power of the DFIGs on bus 9 is increased to 1.038p.u. While the absolute value of the COI accelerating power is decreased. Also, the DFIGs' active powers return back to their normal values rapidly after cleared the fault as



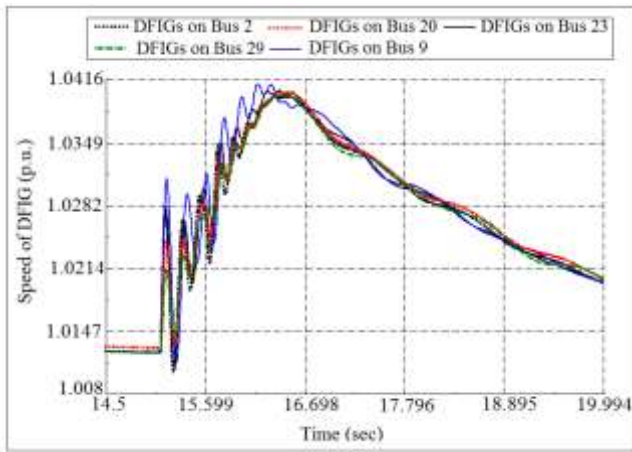

Fig.8. Transient response of DFIG-WFs' Speed in case of adding DFIGs

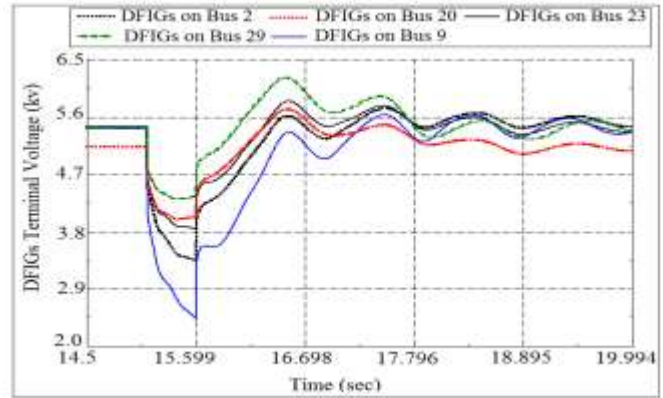

Fig. 10. Transient dynamics of DFIG-WFs' terminal voltage- in case of connecting DFIGs

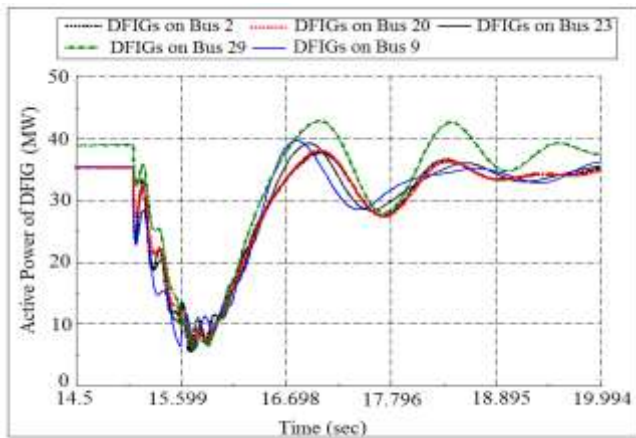

Fig. 9. The electrical power of DFIG-WF'S in case of adding DFIGs shown in Figure 9. This helps the system to reach stability.

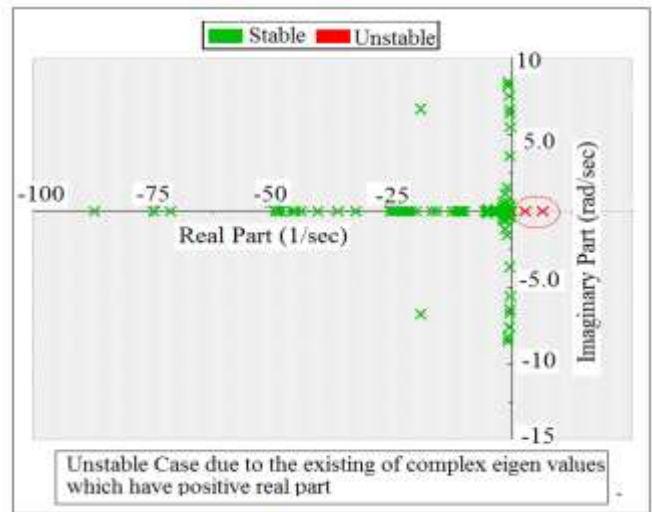

Fig. 11. Eigenvalues plot of the system-with no DFIGs

Figure 10 illustrates the voltage at the terminal of DFIG-WFs. It is cleared that the dynamic response of the DFIGs' terminal voltages during the three-phase fault varies depended on where they are added to the system. So, the terminal voltage of each DFIG in the system is different as illustrated in Figure 10. During the fault inception, the terminal voltage of the DFIG on bus 9 and 29 are 2.4kV and 4.3kV respectively. These differences in terminal voltage of the DFIGs are presented due to the location of the three-phase fault. This explains the difference in  $\Delta P_{DFIG}$  that shown in Figure 8. So, the terminal voltages' dynamics of the DFIGs have a great effect on the electrical power output.

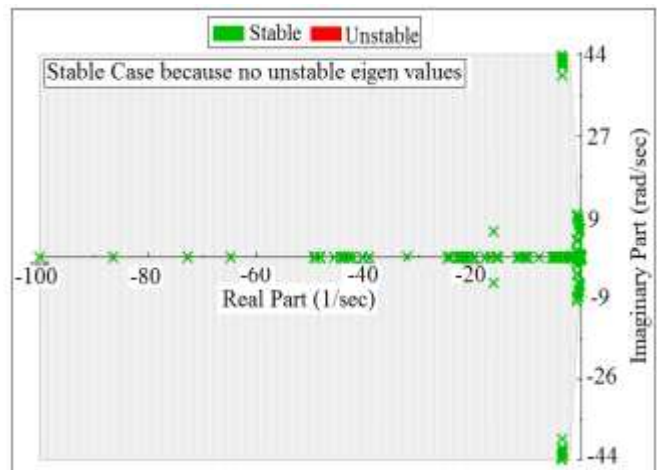

Fig.12. Eigenvalues plot of the system -in case of adding DFIGs

Figure 11 shows the Eigenvalues plot in case of without connecting the DFIGs. The system is unstable due to the existing of the complex eigenvalues which have positive real parts. Figure 12 shows the Eigenvalues plot in case of connecting the DFIGs with a rated capacity of 645MW. By connecting the DFIGs in parallel with the synchronous generators, there are no complex eigenvalues have positive real parts. Also, the negative values of the real part of complex eigenvalues are increased. So, the transient stability is improved.

By connecting the DFIG-WF's, the CCT improves from 15.576sec to 15.598sec compared to the original system without DFIGs. The existing of the DFIGs in the system with synchronous generators provide an improved CCT by a margin of 0.022sec (1.32 cycles). Thus, the previous

simulations illustrate that the existing of the DFIG-WF's in the system with the synchronous generators are useful in improving the system transient stability for critical contingencies.

*B. Scenario#2: with synchronous generators' replacement*

In this scenario, the synchronous generators (G1 at bus 2 and G5 at bus 20) are replaced by a DFIG-WF's with the same capacity of active power.

Based on Eq. (12), the system inertia constant in this scenario can be described by,

$$H'_{J,C} = H_{J,C} - H_{J,G1} - H_{J,G5} \tag{26}$$

where  $H'_{J,C}$  is the COI inertia constant in case of the replacing the synchronous generators by DFIG-WFs with the same capacity.  $H_{J,G1}$  and  $H_{J,G5}$  are the inertia constant of the replaced synchronous generators G1 and G5 respectively.

A three-phase fault occurs at the transmission line 4-14 and the fault is cleared by removing the line as in the first scenario. The fault clearing time is set to be 15.920sec (fault time = 0.820sec).

Figure 13 shows the transient response of the synchronous generators' rotor angles in case of replacing synchronous generators with DFIGs which have a rated capacity 645MW. After the fault is cleared, all the synchronous generators oscillate with low frequency except G3 oscillates with a little high frequency (i.e. 92°). But after a short period of time, all the synchronous generators' rotor angles reach the steady-state value (22° for G3). So, the system transient stability is improved due to decrease the synchronous generators' rotor angles and reach to the steady state quickly after clearing the fault. Figure 14 illustrates the transient response for the synchronous generators' active power. After the fault is cleared, all the synchronous generators oscillate with low frequency except G10 (its value reaches 1221 MW which above its normal load by 22.1 %) and G3 (its value reaches to 1121 MW which above its normal load by 65%) oscillate with a little high frequency. But after a short period of time, all synchronous generators' active power reach steady-state

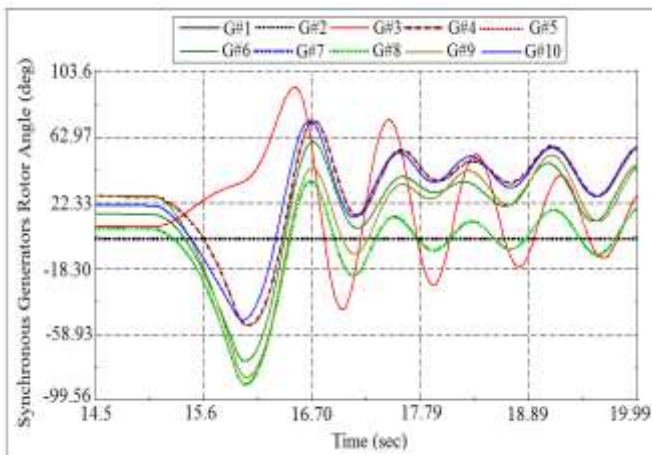

Fig.13. Synchronous generators' rotor angles – in case of replacing synchronous generators with DFIGs values.

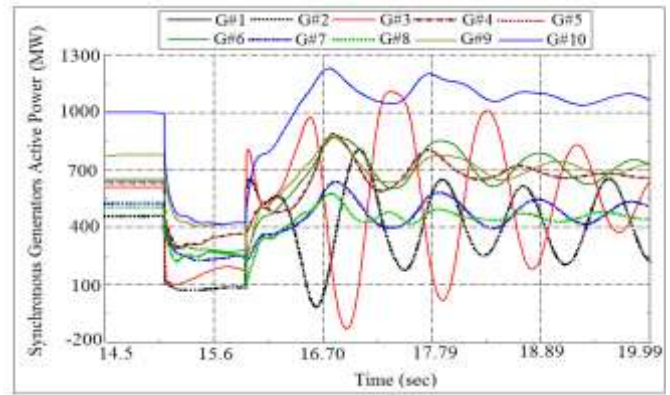

Fig. 14. Synchronous generators' active power in case of replacing synchronous generators with DFIGs

Figure 15 illustrates the transient response for the synchronous generators' rotors speed. It plots the accelerating power and the rotor speed of each synchronous generator during and after the fault. During the fault, all the synchronous generators accelerate (G2 and G3 reach to 3845 r.p.m after small time). After the fault is cleared, all the synchronous generators decelerate except G2 and G3 oscillate before

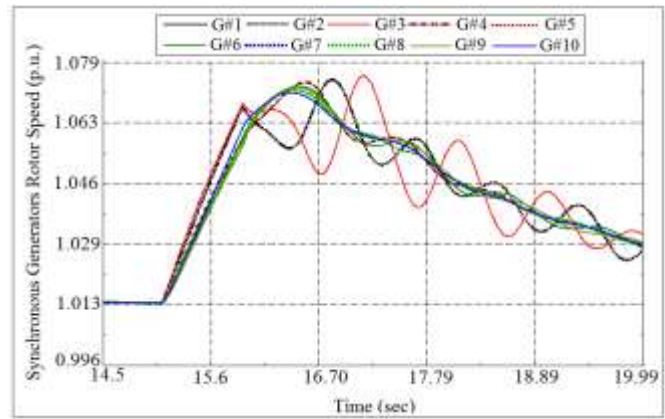

Fig. 15. Synchronous generators' rotor speed – in case of replacing synchronous generators with DFIGs

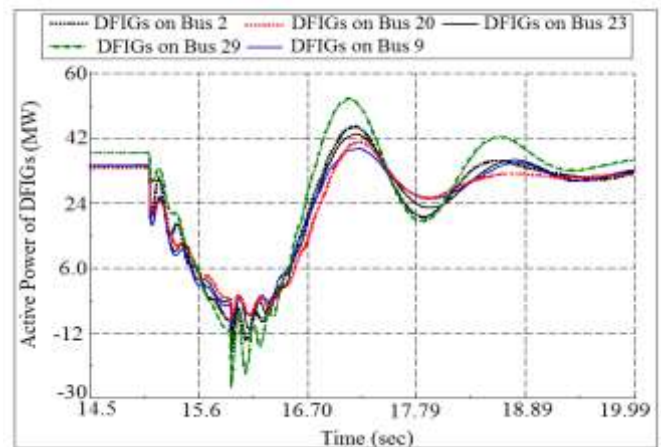

Fig. 16. Synchronous generators' electrical power – in case of replacing synchronous generators with DFIGs reaching the steady-state values. Figure 16 shows the electrical power of the DFIG-WFs.

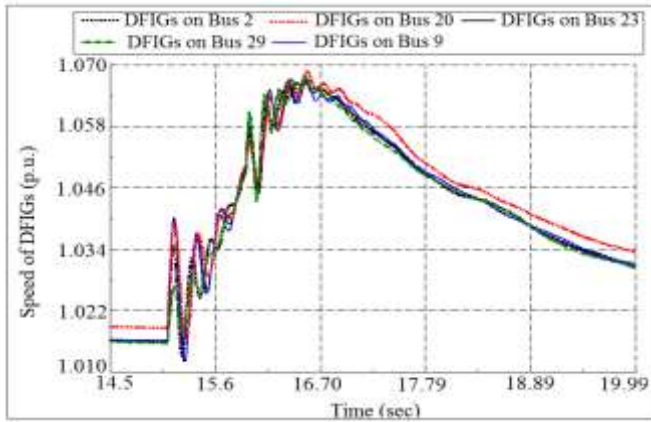

Fig.17. Transient response of DFIG-WFs' accelerating power in case of replacing synchronous generators with DFIGs

It's cleared that, the DFIGs' active power returns back to its normal value rapidly after clearing the fault. This helps the system to reach stability. Figure 17 shows the accelerating power of DFIG-WFs with the rated active power capacity of 645MW.

By substituting the synchronous generators with DFIG-WFs which have the same rated capacity of 645MW, the absolute value for DFIG-WF's accelerating power,  $\Delta P_{DFIG}$ , increases during and after the fault as shown in Figure 18. While the absolute value of COI accelerating power,  $P'_C$ ,

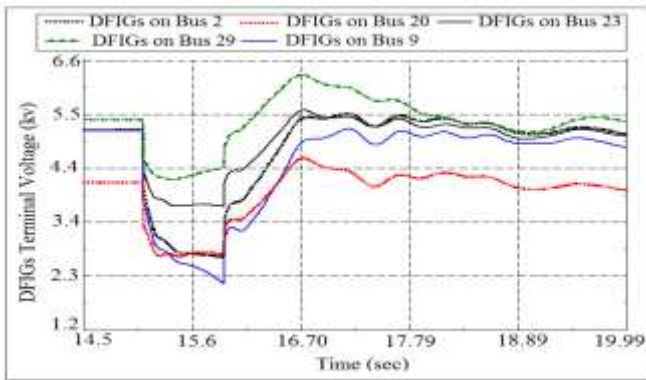

Fig.18. Transient response of DFIG-WFs' terminal voltage in case of replacing synchronous generators with DFIGs

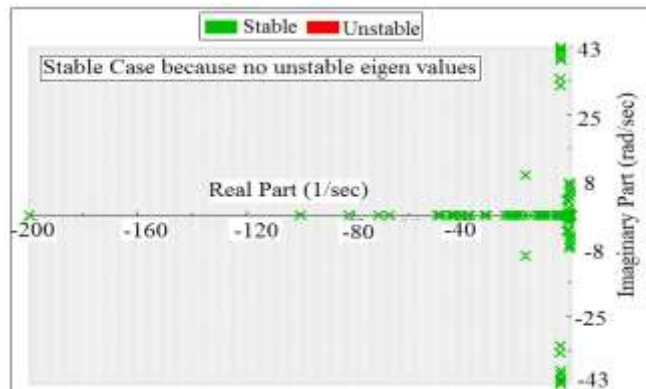

Fig.19. Eigenvalues plot of the system– in case of replacing synchronous generators with DFIGs

decreases. Thus, the system stability increases as shown in Figure 19

Figure 18 shows the terminal voltages of each DFIG. The terminal voltage of each DFIG in the system is different. At the fault inception, the terminal voltage of the DFIG on bus 9 and 29 are 2.22kV and 4.3kV respectively. These differences in voltage at the terminal of the DFIGs are presented due to the location of the three-phase fault. This explains the difference in the absolute value for DFIG-WF's accelerating power,  $\Delta P_{DFIG}$ , as shown in Figure 17. Figure 19 shows the Eigenvalues plot. It explains that the transient stability of the system is improved due to increase the negative values of the real parts of the complex eigenvalues.

By substituting the synchronous generators with DFIG-WFs, the CCT improves from 15.576 sec to 15.928 sec compared with the original system with no DFIGs. So, it provides an improvement to the CCT by a margin of 0.352 sec (21 cycles). Thus, the previous simulations illustrate that the replacement of synchronous generators with DFIG-WFs in the system is useful for improving the system transient stability for critical contingencies.

## VII. CONCLUSION

This article presents the difference between the behavior of conventional synchronous generators and the DFIGs during and after severe disturbances. It discusses the effect of the DFIG-WF's integration on the system dynamic motion in two scenarios. The first scenario is done by connecting the DFIG-WF's into the system in parallel with the synchronous generators; it provides an improved CCT by 0.022 seconds (1.32 cycles). The second scenario is made by the replacement of synchronous generators with DFIG-WFs which have the same capacity of active power; it provides an improved CCT by 0.352 seconds (21 cycles). This means that the second scenario gives more damping for the oscillations than the first scenario. So, it's cleared that the replacement of synchronous generators with DFIG-WFs is more valuable than connecting the DFIG-WF's in parallel with the synchronous generators in improving the system transient stability.

## REFERENCES

- [1] L. P. Jiang, Y. N. Chi, H. Y. Qin, Z. Y. Pei, Q. H. Li, M. L. Liu, J.H. Bai, W. S. Wang, S. L. Feng, W. Z. Kong, and Q. K. Wang, "Wind energy in China," IEEE Power and Energy Magazine, vol. 9, no. 6, pp.36-46, Dec. 2011.
- [2] H. Chen, J. Li, F. Han, and H. Bai, "Power grid is getting ready for the development of wind power in China," in Proceedings of IPEC, 2010, pp. 396-401.
- [3] Y. Feng, H. Y. Lin, S. L. Ho, J. H. Yan, J. N. Dong, S. H. Fang, and Y. K. Huang, "Overview of wind power generation in China: Status and development," Renewable and Sustainable Energy Reviews, vol. 50, pp. 847-858, Oct. 2015.
- [4] M. Rahimi and M. Parniani, "Dynamic behavior analysis of doubly fed induction generator wind turbines-the influence of rotor and speed controller parameters," International Journal of Electrical Power & Energy Systems, vol. 32, no. 5, pp. 464-477, Jun. 2010.
- [5] A. A. B. M. Zin, P. H. A. Mahmoud, A. B. Khairuddin, L. Jahanshaloo, and O. Shariati, "An overview on doubly fed induction generators' controls and contributions to wind-based electricity generation," Renewable and Sustainable Energy Reviews, vol. 27, pp. 692-708, Nov. 2013.

- [6] M. V. A. Nunes, J. A. P. Lopes, H. H. Zum, U. H. Bezerra, and R. G. Almeida, "Influence of the variable-speed wind generators in transient stability margin of the conventional generators integrated in electrical grids," *IEEE Transactions on Energy Conversion*, vol. 19, no. 4, pp.692-701, Nov. 2004.
- [7] H. Hou, L. Lin, T. Wu, and Y. Z. Miao, "Comparison of transient stability between wind farm based on DFIG and traditional power plant in an actual grid," in *Proceedings of IEEE Power and Energy Engineering Conference*, 2010, pp. 1-4.
- [8] Y. C. Zhang, J. Bank, E. Muljadi, Y. H. Wan, and D. Corbus, "Angle instability detection in power systems with high-wind penetration using synchrophasor measurements," *IEEE Journal of Emerging and Selected Topics in Power Electronics*, vol. 1, no. 4, pp. 306-314, Oct. 2013.
- [9] W. Qiao, R. G. Harley, and R. G. Harley, "Effect of grid-connected DFIG wind turbines on power system transient stability," in *Proceedings of IEEE Power and Energy Society General Meeting*, 2008, pp. 1-7.
- [10] D. Gautam, V. Vittal, and T. Harbour, "Impact of increased penetration of DFIG-based wind turbine generators on transient and small signal stability of power systems," *IEEE Transactions on Power Systems*, vol. 24, no. 3, pp. 1426-1434, Jul. 2009.
- [11] J. C. Cepeda, J. L. Rueda, D. G. Colom'e, and D. E. Echeverr', "Real time transient stability assessment based on center-of-inertia estimation from phasor measurement unit records," *IET Generation Transmission & Distribution*, vol. 8, no. 8, pp. 1363-1376, Aug. 2014.
- [12] H. Hashim, M. R. Zulkepali, Y. R. Omar, N. Ismail, I. Z. Abidin, and S. Yusof, "An analysis of transient stability using Center-of-Inertia: angle and speed," in *Proceedings of IEEE International Conference on Power and Energy*, 2010, pp. 402-407.
- [13] Z. B. Du, Y. Zhang, L. Liu, and Y. X. Ni, "COI based frequency slow dynamics simulations of ACDC interconnected power system incorporating AGC," in *Proceedings of IEEE Power Engineering Society General Meeting*, 2007, pp. 1-7.
- [14] P. Kundur, *Power System Stability and Control*. New York, USA: McGraw-Hill Professional, 1994, pp. 946-948.
- [15] S. E. Stanton and D. R. Waggoner, "A center-of-inertia transform applied to transient responses of nonlinear power systems," in *Proceedings of the Twenty-First Annual North American Power Symposium*, 1989, pp. 205-210.
- [16] H. Q. Yi, S. J. Cheng, Z. B. Du, L. B. Shi, and Y. X. Ni, "Modeling and simulation on long-term dynamics of interconnected power system using area COI concept," *Electric Power Systems Research*, vol. 78, no. 8, pp. 1369-1377, Aug. 2008.
- [17] Z. B. Du, Y. Zhang, Y. X. Ni, L. B. Shi, L. Z. Yao, and M. Bazargan, "COI-based back-stepping sliding-mode emergency frequency control for interconnected ACDC power systems," in *Proceedings of IEEE Power & Energy Society General Meeting*, 2009, pp. 1-6.
- [18] Z. H. Hao, Y. X. Yu, and Y. Zeng, "Transient performance of DFIG power angle in wind farm and its control strategy," *Electric Power Automation Equipment*, vol. 31, no. 2, pp. 79-83, Feb. 2011.
- [19] C. Feltes, S. Engelhardt, J. Kretschmann, J. Fortmann, F. Koch, and I. Erlich, "Comparison of the grid support capability of DFIG-based wind farms and conventional power plants with synchronous generators," in *Proceedings of IEEE Power & Energy Society General Meeting*, 2009, pp. 1-7.
- [20] T. Ahmed, K. Nishida, K. Soushin, and M. Nakaoka, "Static VAR compensator-based voltage control implementation of single-phase self-excited induction generator," *Electric Power Systems Research*, vol. 78, no. 9, pp. 1477-1484, Sep. 2008.
- [21] Y. Pipelzadeh, B. Chaudhuri and T. Green, "Wide-Area Power Oscillation Damping Control through HVDC: A Case Study on Australian Equivalent System", *IEEE Power and Energy Society General Meeting*, July 2010.
- [22] M. A. Pai, "Energy function analysis for power system stability", Springer, 1989.