

11-16-2021

Design of Stand-Alone Solar PV Power System Installed Atal-Mansoura-Egypt Driving 5.5 KW Elevator.

Saad Eskander

Professor of Electrical Engineering Department, Mansoura University, El-Mansoura, 36615, Egypt, saadeskaudere@mans.edu.eg

Alaa Mghames

Researcher of Electrical Engineering Department, Mansoura University, El-Mansoura, 36615, Egypt, alaabunyan@gmail.com

Mohamad Elsayess

Professor of Electrical Engineering Department, Mansoura University, El-Mansoura, 36615, Egypt, alaabnein@gmail.com

Hanan Al-Baihani

Lecturer of Electrical Engineering Department, Aden University, Yemen, behani_73h.h@yahoo.com

Ahmed Eid Moussa Shahin

Associate Professor of Electrical Engineering Department, Mansoura university, El-Mansoura, 36615, Egypt, ahshein@mans.edu.eg

Follow this and additional works at: <https://mej.researchcommons.org/home>

Recommended Citation

Eskander, Saad; Mghames, Alaa; Elsayess, Mohamad; Al-Baihani, Hanan; and Eid Moussa Shahin, Ahmed (2021) "Design of Stand-Alone Solar PV Power System Installed Atal-Mansoura-Egypt Driving 5.5 KW Elevator.," *Mansoura Engineering Journal*: Vol. 46 : Iss. 3 , Article 13.

Available at: <https://doi.org/10.21608/bfemu.2021.205143>

This Original Study is brought to you for free and open access by Mansoura Engineering Journal. It has been accepted for inclusion in Mansoura Engineering Journal by an authorized editor of Mansoura Engineering Journal. For more information, please contact mej@mans.edu.eg.



Design of Stand-Alone Solar PV Power System Installed Atal-Mansoura-Egypt Driving 5.5 KW Elevator

Saad Eskander, *Alaa Bunyan**, *Mohamed Adel Elsayess*, *Hanan H.Baihani* and Ahmed Shahin

KEYWORDS:

Tilt angles, Elevator, Solar PV system, Module 435 Wp, Proposed method.

Abstract— This research is devoted to studying the electrical performance of the stand-alone solar PV system, used for feeding a 5.5 kW Elevator. The load is represented by an induction motor connected with the elevator electrical system. The selected solar PV modules are chosen from Egyptian markets. The (I-V) performance of the selected solar PV modules initially investigated. The electrical power generated from solar PV modules measured at different load values as well as at various solar radiation levels. Consequently, the output energy is recorded during the daytime at different solar PV module's tilt angles. As the tilt angles are at 0, 11, and 31 degrees, and in the summer season the best tilt angle is detected at zero degrees in one day. Two different design techniques are used in design to explore the accurate technique of solar PV systems. The proposed method requires experimental data for the solar module used in the design. This is a quick method for designing PV systems. The method depends on the number of peak sun hours (PSH) which varies from one site to another.

I. INTRODUCTION

RENEWABLE energy is the new development that is heading the world. They are very expensive to purchase and design. In a short period, this cost is covered compared to production. It is clean energy

Received: (20 April, 2021) - Revised: (09 August, 2021) - Accepted: (17 August, 2021)

Prof. Saad Eskander, Professor at Electrical Engineering Department, Mansoura University, El-Mansoura, 36615, Egypt, (E-Mail: Saadeskaudere@Mans.edu.eg).

**Corresponding Author: Alaa Bunyan, researcher at Electrical Engineering Department, Mansoura University, El-Mansoura, 36615, Egypt (E-Mail: Alaabunyan@Gmail.com)*

Prof. Mohamed Adel Elsayess, Professor at Electrical Engineering Department, Mansoura University, El-Mansoura, 36615, Egypt, (E-Mail: alaabnein@gmail.com).

Hanan H. Al-Baihani, Lecturer at Electrical Engineering Department, Aden University, Yemen (e-mail: Behani_73h.h@yahoo.com.)

Prof. Ahmed Shahin, Associate Professor at Electrical Engineering Department, Mansoura University, El-Mansoura, 36615, Egypt, (E-Mail: ahshein@mans.edu.eg)

and environmentally friendly [1]. It is considered less expensive when compared to the diesel generators that run on fossil fuels, which are highly polluted [2-3]. Especially in areas that do not have access to electrical energy sources, as well as in agricultural areas that need irrigation. Renewable energy is one of the most important renewable sources of energy. They are available and especially present in areas that are exposed to solar radiation throughout the year [4-5]. The surplus energy generated from solar cells can be used later. This energy can be stored by one of the basic storage methods available at the present time, such as batteries. This is one of the main and important storage methods which depends on it to store the excess energy. The stored energy is used in times of night and in cloudy weather [6]. In the solar energy system, the maximum energy can be obtained by studying the electrical properties. It depends on obtaining the maximum energy through the correct orientation of the solar cells. So that the solar radiation falling on the solar cells is vertically as possible to take advantage of it in obtaining the maximum energy. By studying the current and at maximum power by studying the different tilt angles. Egypt is among the countries

that enjoy high solar radiation and is available throughout the year and contains the most important solar energy stations in the city of Aswan [7]. In this paper, a new solar PV module was chosen and available in the Egyptian market. The chosen module is 435 Watts. Its electrical performance is studied and investigated in the summer season and temperature of 35 degrees [8]. The aim of studying this module is to take advantage of it in equipping a converter to be thus elevated to higher energy to feed certain loads in the Solar Energy Laboratory, Faculty of Engineering, Mansoura University. To obtain high efficiency [9-10], and some other properties that are studied in this research. And two methods are used to design the solar PV systems. The proposed method is more accurate than the classic method. Through the research, the total life cycle cost of the solar PV system is determined. Classical method is actually a NASA method. Calculations of the number of solar panel in the classical method are based on the maximum power value given in the nameplate of the solar panel. The number of solar panels obtained by this method is only accurate for the panel test site during manufacturing and cannot be generalized or relied upon when calculating the number of panels for other sites. If it is generalized to other sites it will result in an incorrect number of solar panels and thus an increase in the total cost in the case of obtaining more than necessary number of solar panels. On the other hand, lower efficiency of the photovoltaic power system in case the number of panels obtained is less than necessary. In addition to this, the classical method does not depend on the tilt angle at calculation [11-12]. The proposed method in this paper contributes to avoiding this shortcoming in the classical method, as it depends upon a one-day experimental test in the area in which the solar system is intended to be constructed and utilized. Unlike the classical method, this method can be generalized to different sites.

II. CHARACTERISTICS OF THE USED TESTED MODULE

Initially, the I-V characteristics of the 435 Wp solar cells module are recorded experimentally, the readings are recorded at different solar insolation levels as along with at different tilt angles. These angles illustrate that the angles of operation of the solar PV system during the summer season. The following figures illustrate the recorded date of current and voltage output of the selected module at different insolation levels a different times with a zero tilt angle (horizontal tilt angle).

Fig. (1) shows the module has 156 solar cells connected in two groups. Each group contains 78 cells connected in series; the two groups are connected in parallel. The open-circuit voltage of the tested module is 51.6 V. It has a short circuit current referred to the maximum insolation level is 10.7A, and the maximum output power at maximum solar radiation level is 435 Watt. The voltage and current referred to as the maximum power point are 43.5V and 9.99 A in [appendix A1]. The module size is 2.167 m * 0.998 m, approximately

has an area of 2m². The module output power depends upon its tilt angle. The amount of energy delivered during the daytime period is in the range of (2kWh/day < E (output energy) < 2.5 kWh/day). The tested module output data are classified into three groups. Each group is referred to as one tilt angle. In this paper, the tilt angles selected for the module are zero, 11, and 31 degrees referred to as the horizontal. These angles are carefully selected for the system operation during the summer season. The system is adjusted according to these angles during the operation to get the maximum output power from the module.



Fig. (1) Photograph of (435 Wp) module

III. OPERATION CHARACTERISTICS OF THE PV MODULE

The operation of the module has been investigated according to three different tilt angles. A one-day experimental test is carried out in solar laboratory Mansoura city-Egypt with three different tilt angles. These angles are zero, 11, and 31 degrees. The tilt angle of 31 degrees is selected depending on the latitude angle of the test site. Usually, the best tilt angle is less than the latitude angle. Angles zero and 11 degrees are chosen based on the summer season because the solar radiation falling on the earth's surface is vertical or almost vertical.

3.1 Module Operation of the Module at Zero Tilt Angle

Fig. (2) illustrates the I-V electrical characteristics of the tested module at zero tilt angles at different instants during the daytime period. The experimental investigation during the test shows that the solar radiation during the summer season reaches its maximum value approximately at the time of 9:30 am. The solar radiation is nearly constant at its maximum amplitude during a period of five hours, this period represents the solar sun during the summer season. This means that the best operation time of the solar photovoltaic irrigation system is in the range of 9 am < t < 3 pm, during this period of operation, the irrigation system operates directly from the designed solar cells array. On the other hand, for a time range from of {sunrise (6 am) ≤ t ≤ (9 am) and (3 pm) ≤ t ≤ sunset (6

pm)} during these periods. The irrigation solar photovoltaic power system must be stopped from operation. During the last period, the irrigation system discharges a small amount of water required for irrigation purposes. The electrical solar energy output of the PV system has been stored by using a battery, as it is the best storage system. So, the electrical load must be supplied its energy from the battery storage system. For this purpose, the depth cycle of discharge battery types is the best choice. Fig. (2) shows that the voltage at maximum power points, and as it is clear from the figure that the maximum power point of all families of curves is nearly at 40V. The current at maximum power points of the whole characteristics depend upon the level of the insolation, it has its maximum value at time 9:30 am, with a value of nearly (7.7 Amps).

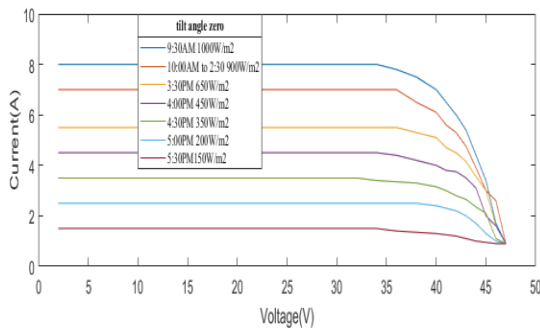
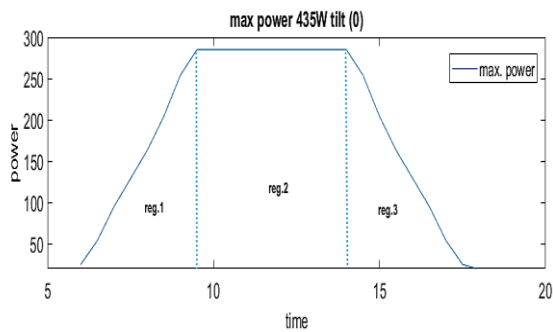
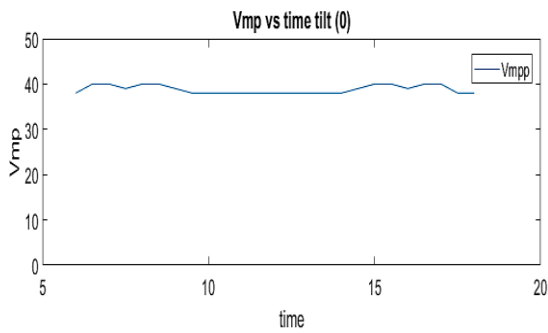

Fig. (2) I-V electrical characteristics of tested module at zero degree tilt angle



(a)



(b)

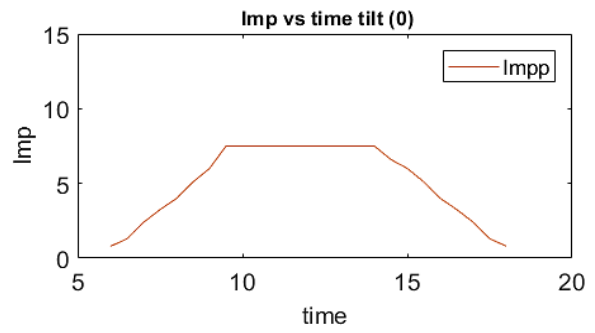

(C)

Fig.(3) (a). Maximum power output of the tested module VS daytime. (b). The voltage of the maximum power point of the tested module and tilt angle of zero degrees. (C) .The current of the maximum power point of the tested module and tilt angle of zero degrees.

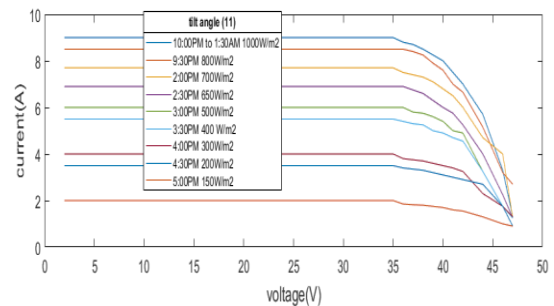

Fig. (4) I-V electrical characteristics of tested module at 11 degrees

Fig. (3a) illustrates the maximum power output of the tested module throughout the daytime. This curve can be divided into three regions. The first region starts from the period of sunrise to 9:30 am, and we notice an increase in solar radiation, which leads to an increase in the current, and the area under the curve is an almost right-angled triangle, the energy produced from this region is equal to 0.6kWh/day. As for the second region, this period starts from 9:30 am to 2:30 pm, and we notice from this period that the intensity of solar radiation is constant, which results in a constant value of current, and the area under the curve is a rectangle, the energy produced from this area is equal to 1.2kWh/day. Thus, the benefit of this period to obtain a current of constant value and the estimated operating hours in it are about five hours. As for the third region, this period starts from 2:30 pm until sunset, and we notice from this period that the intensity of solar radiation gradually decreases until it reaches zero at the time of sunset, which leads to the current intensity decreasing also until it reaches zero and the area under this curve is about an almost right-angled triangle. The energy produced from this period is approximately equal to 0.6kWh/day. From which we can see that the energy of the first and the third regions, which represent a triangular shape, is equal most of the time and their sum is equal to the energy of the second region. The total energy output from the module is near 2.4 kWh/day.

Fig. (3b) shows that the voltage is nearly constant during the daytime with a value approximately equal to 40V.

Fig. (3c) illustrates the current at maximum power output of the tested module against the daytime. It has an electrical behavior as the maximum power point characteristic.

Fig. (4) shows the experimental data recorded for the solar PV module under test (435 Wp) at different daytimes during the day period from 10 AM to 5 PM. The previous data recorded with the solar PV module tilt angle by an angle of 11 degrees from the horizontal. The experimental data measured for the tested solar module is taken during one daytime of the summer season. The family of curves of the I-V characteristics is obtained at different times throughout, the previous period of the selected day is shown in Fig.(4). These Fig. show the open-circuit voltage of the tested module is nearly constant at the insolation levels. While the short-circuit current of the module (435 W) is heavily dependent on the solar insolation.

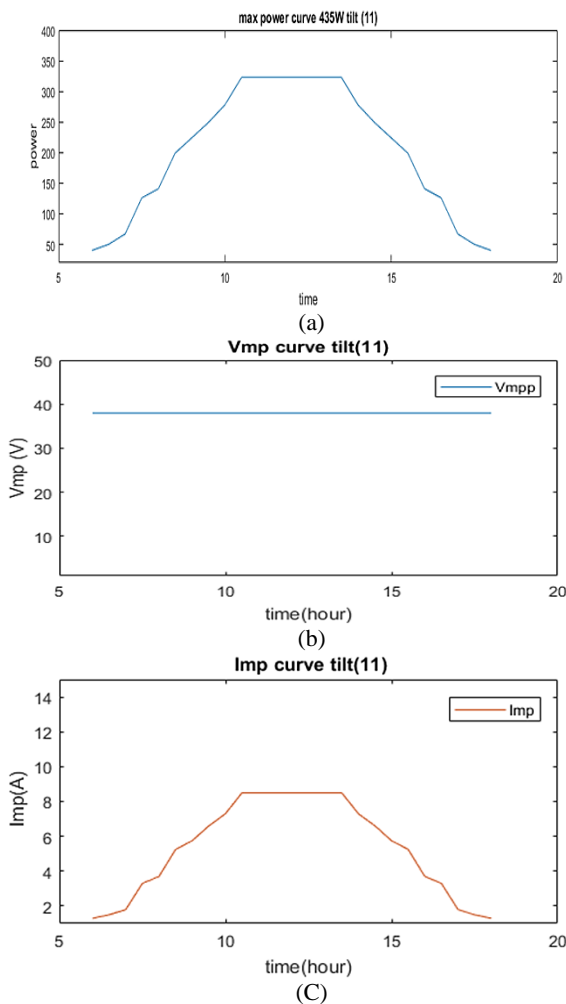

Fig.(5) (a). Maximum power output of the tested module VS daytime. (b). The voltage of the maximum power point of the tested module and tilt angle of 11 degrees.(c) . The current of the maximum power point of the tested module and tilt angle of 11 degrees.

Fig. (5a) shows the maximum power output of the examined module from the sunrise instant to sunset. This curve shows the same behavior as in Fig. (3a). The area under

the maximum power point curve represents the maximum output energy that can be taken from the studied solar module during the selected day, the value of the maximum energy extracted from the solar module represents the most important value which will be used later in the design of solar PV system. The previous curve has the peak value at the period of (10 AM to 3 PM).

Fig. (5b) reveals the voltage of the maximum power point of the tested PV module at a tilt angle of 11 degrees from the horizontal. Fig. (5b) shows that the value of the last voltage is nearly constant at the value of 40 voltages and it is dependent on the insolation level. This means that the voltage of the maximum power point is nearly constant during the daytime period. To extract the maximum power from the solar PV module, the module must be operated at a fixed voltage of maximum operating PowerPoint. There are two techniques that can be used to fix the output voltage of the solar PV module:

- 1- By using batteries bank of voltage equals the power point (MPP).
- 2- By using the power electronic dc-dc converter (boost). The converter follows the maximum operating power point of the solar PV array. The maximum operating power point tracker device is designed for this purpose in the Solar Energy Laboratory at the Faculty of Engineering - Mansoura University. This device is easy to design for any module or array type. The second technique is the most accurate selection for the design of the maximum operating PowerPoint.

Fig. (5c) shows the characteristics behaviors of the current at the maximum operating PowerPoint of the tested module VS the daytime (at different insolation levels). The characteristics take the same behaviors as the maximum operating PowerPoint characteristics. The area under the curve of the current of the maximum power point gives the designed value and the capacity of batteries connected with the solar module.

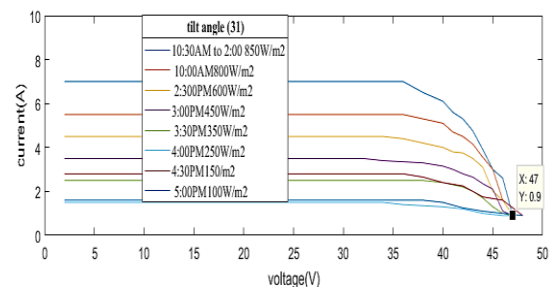

Fig. (6) I-V electrical characteristics of tested module at tilt angle of 31 degrees

Fig.(6) illustrates the I-V curves of the tested module throughout the daytime.

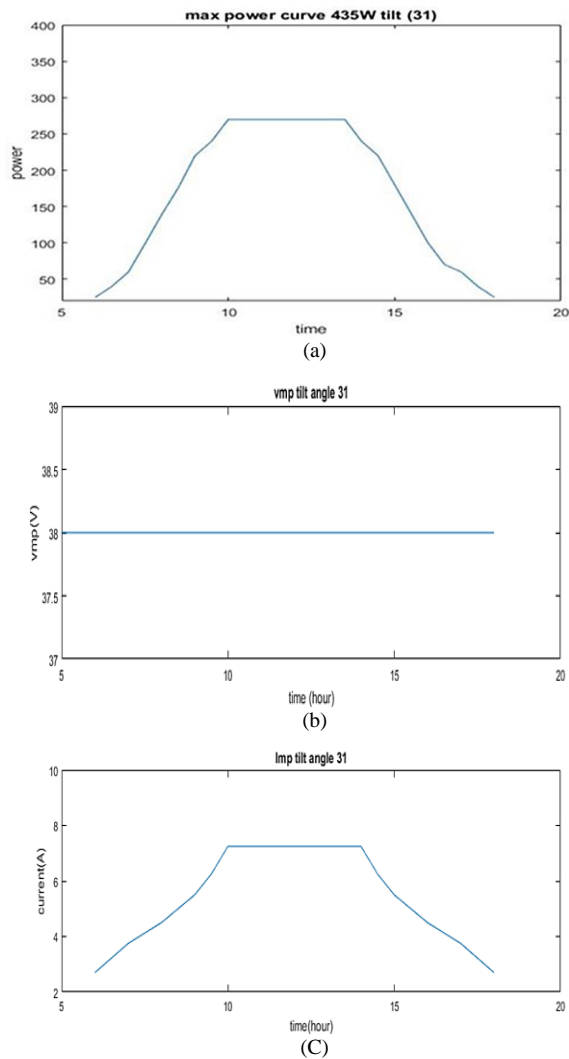

Fig.(7) (a). Maximum power output of the tested module VS daytime.(b). The voltage of the maximum power point of the tested module and tilt angle of 31 degrees.(c). The current of the maximum power point of the tested module and tilt angle of 31 degrees.

Fig.(7a) represents the maximum operating power point curve of the selected tested module.

Fig.(7b) represents the voltage at the maximum operating power point of the tested module.

Fig. (7c) shows the electrical characteristics of the current at the maximum power point. The characteristics take the same behavior of the characteristics of the tested module at zero tilt angle as well as at 11 degrees.

IV. EFFECT OF THE TILT ANGLE ON THE PRODUCED POWER.

The maximum output power of the tested solar cells module (435 Wp) at different tilt angles is calculated. Fig. (3a), (5a), and (7a) represent the maximum power output of the tested module at tilt angles of zero, 11, and 31 degrees, respectively. The areas under the curves are estimated numerically. The area under each curve consists of three regions, the two others are similar. The two similar regions are

taken as a triangle the first triangle region starts from sunrise instant to instant of (10 AM). The second triangle region starts from the instant of (3 PM) to the sunset instant. The area of the two triangles is equal. The area of the two triangles at zero tilt angle is (1.25 kWh/day). The third area under the maximum power point curve represents a rectangle The area of this rectangle at zero tilt angle equals the two triangles. Hence, the total energy output at a zero tilt angle is (2.5 kWh). The produced energy of the module at 11 degrees tilt angle is estimated from Fig. (5a); the same steps taken at zero tilt angle are used also for the energy extracted. The maximum output energy of the tested module is estimated from Fig. (7a) and equals (1.9 kWh/day).

Fig.(8) compares the tilt angles beside the maximum output energy of the module. The figure shows zero tilt angle is the best of the all. This means that the solar insolation during the test the instant, perpendicular on the solar module nearly during the test day, hence; the best tilt angle during the summer season for the test site (Mansoura city) is zero.

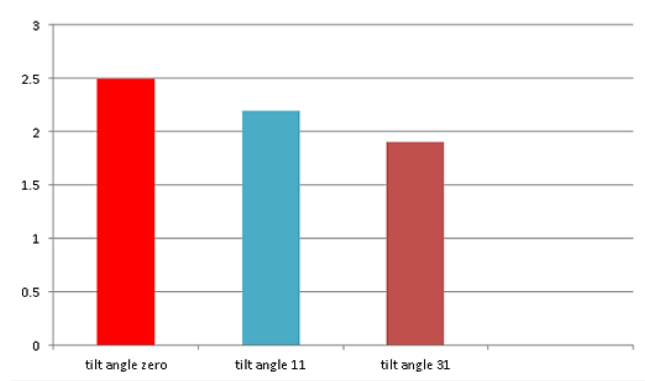

Fig. (8) The maximum output energy of the tested module at different tilt angles

V. SIZING OF PV SYSTEM SUPPLIES 5.5 kW ELEVATOR

Several methods can be used in sizing the PV system used to supply a certain load. The most used method is the classical method. This method is used for sizing the 5.5 kW PV system that supplies the elevator [appendix A2]. This method is based on the experimental results. This method is applied in the Solar Energy Laboratory, Faculty of Engineering, Mansoura University. The proposed method requires experimental data of the module used in the design. Hence, experimental works are carried out. So, the electrical behaviors of the selected module are initially investigated.

Comparison between the proposed and the classical method is being carried out.

5.1 The proposed sizing method.

The proposed method depends on a number of important steps for designing a photovoltaic system, as given below:

1. Calculation of daily total energy of the load (EI).

2. The daily total energy of the load is divided by (the efficiency of the inverter and the efficiency of the MPPT) to get the daily total energy output of the solar panels (E_{mo}).
3. The result of step 2 divided by the total daily energy (E_{mo}) of one solar panel (from experimental laboratory result) to get the number of solar panels required in the design
4. The total daily energy produced by one solar panel (E_{mo}) is calculated through one day experimental test of one solar panel from sunrise to sunset to obtain the maximum energy.

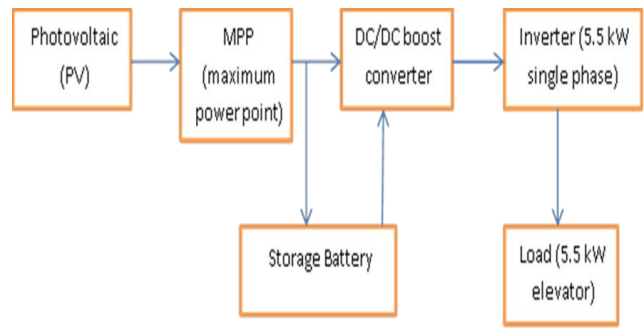

Fig.(9): The block diagram of solar PV system supplied electrical elevator

The proposed method requires experimental data for the solar module used in the design. Hence, the solar module used for the design is initially selected from the solar market. 435 Wp solar module is the up-to-date module in the solar market of Egypt. So, this module is selected to design a 5.5 kW PV system that supplies the required load elevator. The electrical behavior of the selected module is investigated experimentally. Fig. (2) illustrates the I-V C/Cs of the selected module at zero tilt angle throughout the daytime. The previous C/Cs are experimentally required for the 435 Wp module at the laboratory. The maximum power point of the whole I-V C/Cs of the selected module is determined. Fig. (3) shows the relation shapes between the points of the maximum power output of the selected module against the daytimes of the sunshine period during a sunny day of the summer season. The last curve represents the important behavior of the tested module required for the design using the proposed method.

5.1.1. 5.5kw PV System Supplies Elevator

Fig.(9) shows the elements of the solar PV used for supplying the elevator. Each element of the solar PV system is properly sized by the propose method.

5.1.2. Sizing of the Solar Modules

Sizing the solar PV module means that, the determination of the number of modules of the type of 435 Wp required for supplying the 5.5 kW elevator. The previous number of modules is determined based upon the required load energy during all-day hours as well as the output energy of the test module during the sunshine period

$$N = \frac{El}{\eta_{inv} * \eta_{batt} * \eta_{reg} * E_{mo}} \tag{1}$$

Where:

- N : is the number of modules of 435 Wp,
- El : is the total energy required by the load during 24 hours,
- η_{inv} : is the inverter efficiency,
- η_{bat} : is the batteries efficiency,
- η_{reg} : is the voltage regulator efficiency, and
- E_{mo} : is the 435Wp modules energy.

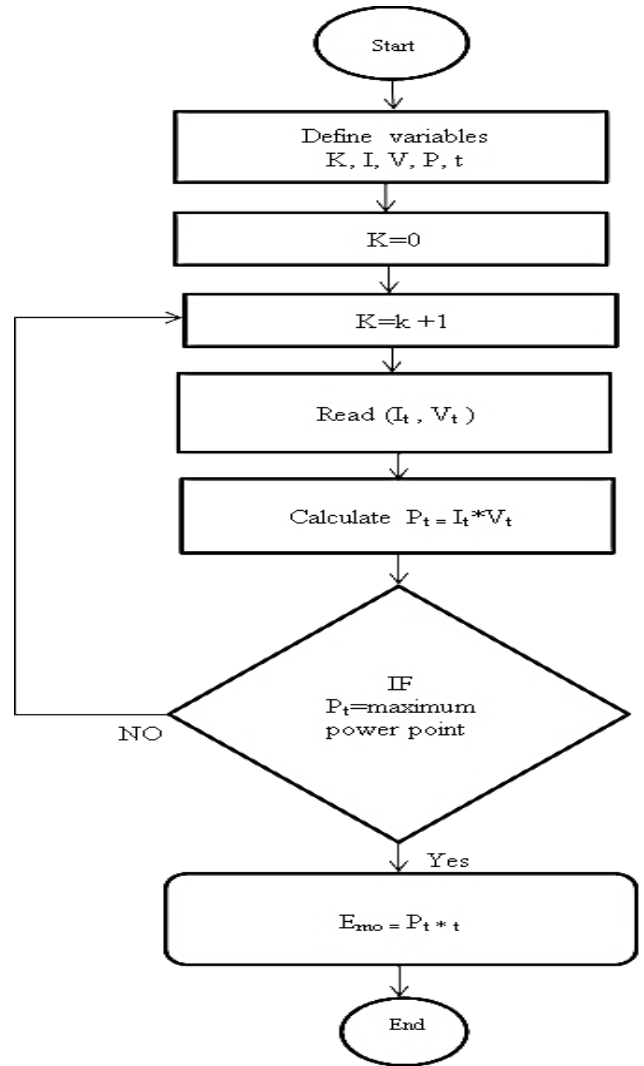

Fig. (10) The daily total energy of the solar panel 435W

Where:

- I_t : is the current value at time,.
- V_t : is the voltage value at time,.
- P_t : is the power value at time,
- t : is the time from sunrise time to sunset time, and
- K : is the counter.

5.1.3. Determination of 435 Wp module generated energy (Emo)

Fig.(3a) is required from the data output of Fig.(2)by using the Matlab software. Fig.(10)illustrates the flow chart used for determining the output of the module energy during the daytime using the Matlab. This energy is actually equal to the area under the curve of Fig.(3a). The result of the Matlab program gives: $E(mo)=2.4$ kWh/day.

5.1.4. Determination of the daily consumed energy of the load throughout the daytime

To determine the daily consumed energy in the elevator, it needs theestimation of the load duration time. The rated power of the elevator electrical motor is estimated by the followingformula:

$$P = \frac{N_{pa} * M * G * S * (1 - Fc)}{\eta(m)} \quad (2)$$

Where:

- P is the rated power of the elevator electrical motor,
- N_{pa} is the number of persons,
- M is the person mass where normally equals to 75 kg,
- G is the gravity acceleration and equal to 9.81 m/s^2 ,
- S is the elevator speed in m/s,
- FC is the factor of safety is less than unity,
- $\eta(m)$ is the motor efficiency.(Efficiencyof themotor and thegear boxare selected from 40% to 80%).

Where the speed of the elevator, S ,is selected as:

- 1- (0.5 m/s for three stages or less than that),
- 2- ($0.5 < S \leq 0.75$ m/s for thefive stages of building or bigger than three stages),
- 3- ($1 < S \leq 1.5$ m/s for eight stages),
- 4- ($1.5 < S \leq 2$ m/s for maximum ten stages or bigger than five stages), and so on.

The daily duration load curve is estimated as shown in Fig. (11) as the daily load curve consists of several durations as follows,

1. From 1:00 AM to 6:00 AM, the average load is nearly equal to 900 Watt. Hence the energy consent by the motor through this period is equal to 4500 Wh.
2. From 6:00 AM to 7:00 AM, the average load is nearly equal to 2400 Watt. Hence the energy consent by the motor through this period is equal to 2400 Wh.
3. From 7:00 AM to 3:00 PM, the average load is nearly equal to 3000 Watt. Hence the energy consent by the motor through this period is equal to 24000 Wh.
4. From 3:00 PM to 6:00 PM, the average load is nearly equal to 1800 Watt. Hence the energy consent by the motor through this period is equal to 7200 Wh.
5. From 7:00 PM to 10:00 PM, the average load is nearly equal to 3000 Watt. Hence the energy consent by the motor through this period is equal to 9000Wh
6. From 10:00 PM to 1:00 AM, the average load is nearly equal to 1800 Watt. Hence the energy consent by the motor through this period is equal to 5400 Wh.

So, the total energy consent by the elevator motor during the daily period 24 hours is;

$$EL = 52500 \text{ Wh/day.}$$

So, by using Equation(1). In

$$Np = 25 \text{ modules.}$$

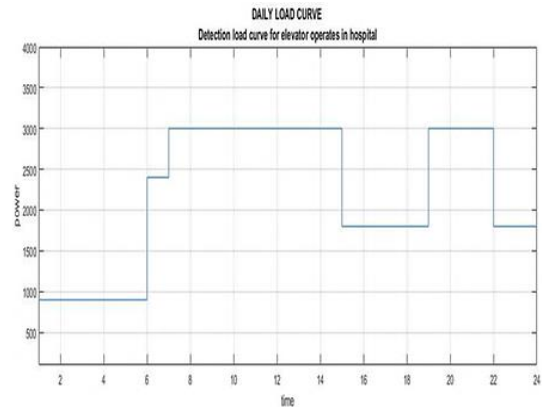

Fig.(11): Daily Load Curve of the elevator

5.1.5. Batteries bank sizing

The batteries used bythePV system are chosen from the deep cycle batteries type. In Egypt's solar market, the maximum size of the deep cycle battery is 200 AH. Therefore,this type of battery is selected to operate as the storage element of PV system. This type of batteries has a capacity of $E_{batt}= 200 * 12 = 2.4$ kWh.

So the number of batteries required to operate in 5.5 kW PV system is determined as

$$N_{batt} = \frac{El}{\eta_{inv} * \eta_{batt} * DOD * E_{batt}} \quad (3).$$

Where:

N_{batt} :is the number of the batteries.

DOD : is the depth discharge of thebattery which equal to 75%.

So the number of batteries required to operate with 5.5 kW PV elevator is,

$$N_{batt} = 32 \text{ batteries.}$$

5.1.6. The inverter sizing

The inverter is selected according to the power of the load and its maximum current hence the inverter ratings are,

$$KVA (inv) = \left(\frac{P(load)}{(P.F) * (\eta(inv.))} \right) \quad (4)$$

Where:

$KVA(inv)$: is the kVA rated of the inverter,

$P(load)$: is the maximum power of the load, and

$P.F$: is the load power factor.

The selected inverter rating of kVA must be greater than the calculated value from Equation (4). Hence, the best selection of the inverter operates in 5.5 kW PV system is,

$$KVA(inv) = 7.5 \text{ kVA.}$$

5.1.7. Voltage Regulator

Maximum power point tracking (MPPT) is a technique used commonly with solar cell systems (PV) to maximize power extraction under all conditions. MPPT is the process of finding this point and keeping the load c/c_s .

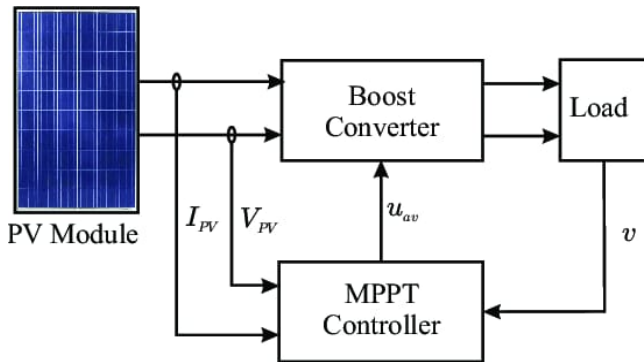

Fig.(12) Block diagram maximum power point tracking

An electronic device that regulates the electrical voltage coming from the solar PV power system before passing it to the batteries. It also has importance and it is as follows:

- 1- Protect the solar cell from damage due to shortness
- 2- Purification and stabilization of the voltage between the battery and the solar cells and between the loads
- 3- Adjust the disconnection voltage of the loads when they rise and fall
- 4- Choose the charging system according to the type of battery
- 5- Setting the working voltage and disconnecting the panels
- 6- Ensure that the batteries are not over-discharged
- 7- Knowing the status of the batteries charge

5.2. Quick Classical Method

The classical method depends on a number of important steps for designing a photovoltaic system, as shown below:

1. Calculation of daily total energy of the load (El).
2. The daily total energy of the load (El) is divided by (the efficiency of the inverter and the efficiency of the MPPT) to obtain the daily total energy output of the solar panels (E_{mo}).
3. The result obtained from step 2 is divided by the maximum power (435W) given in the module nameplate [appendix A1]
4. The result obtained from step 3 is divided by peak sun hours (PSH) to obtain the number of the solar panels.

This is a quick method for designing PV systems. The method depends on the number of peak sun hours (PSH) which varies from one site to another. This method is not accurate, but it is quick for the design. The load duration curve during the daily time is required. The energy required by the load is calculated from the load curve. Hence, the energy output of the array feeding the load is calculated from:

$$E_o = \frac{El}{\eta_{inv} * \eta_{batt} * \eta_{reg}} \quad (5).$$

Where:

E_o : is the required daily energy to the load,

Then, the rating of the solar PV array required for the load.

$$P_o = \frac{E_o}{H_p} \quad (6)$$

Where,

P_o : is the maximum power output from the array during the peak sun hours,

H_p : is the number peak sun hours (PSH),

So, the number of modules required for supplying the load is given by

$$N_p = \left(\frac{P_o}{P_{mmax}} \right) \quad (7)$$

Where,

N_p : is the number of modules of the array.

P_{mmax} : is the maximum power output of the module at standard test condition (STC).

For the selected module to be used in the design, $P_{mmax} = 435$ Wp. This method takes the energy output of the module during only the peak sun hours. Hence, the number of modules obtained by this method will be greater than the number of modules designed by the propose method.

5.2.1 Drawbacks of the classical method

There are two main drawbacks in the classical method comparing with the propose, these drawbacks are,

- 1- Number of modules obtained by using this method is greater than that obtained by using the proposed one.

$$N_{pp} = 25 \text{ modules}$$

$$N_{pc} = 30 \text{ modules}$$

Where,

N_{pp} is the number of modules determined by the proposed method.

N_{pc} is the number of modules calculated by the classical method.

- 2- There is the excess energy output of the array and does not store in the batteries. This excess energy will be lost in the solar PV system circuit. This is due to that, the number of batteries determined by the proposed method has the same values obtained by using the classical method.

5.3. Cost of the kWh Produced by the Designed Solar Pv System

Total life-cycle of the PV system components is as follows:

- 1- Solar cell module has 25 years life time.
- 2- battery has 5 years life time.
- 3- inverter and regulator 10 years life time.
- 4- wiring systems 15 years life time.

There are two types of costs relating to the solar PV system:

- 1- fixed cost.
- 2- running cost.

The fixed cost relating to the cost of PV module, batteries, inverter/regulator, wiring systems and installation cost.

Where:

The running cost is related to the maintenance and labor cost.

Hence, the total lifetime cost of the solar PV system is calculated during five stages. So,

$$T_{LTC} = \sum_{n=1}^5 Tltc(n) \quad (8)$$

Where:

T_{LTC} : is the total lifetime cost of the solar PV system during 25 years,

$Tltc(n)$: is the total lifetime cost for the stage of the whole lifetime of the PV system.

N is the stage number.

The stage is equal to 5 years.

Hence the total

$$Tltc = Tltc(1) + Tltc(2) + \dots + Tltc(5) \quad (9)$$

5.3.1. Calculation of TLTC(n)

$$Tltc(1) = Ca + Cb + Cinv + Cw + Ci \quad (10)$$

Where:

Ca : is the cost of the array,

Cb : is the cost of the batteries,

$Cinv$: is the cost of the inverter and the regulator,

Cw : is the cost of the wiring systems,

Ci : is the cost of the installation systems.

$$Tltc(2) = Cb \quad (11)$$

$$Tltc(3) = Cb + Cinv \quad (12)$$

$$Tltc(4) = Cb + Cw \quad (13)$$

$$Tltc(5) = Cb \quad (14)$$

5.3.2. Determination of the Running Cost

This type of cost is related to the labor cost. For 5.5 kW PV system,

$$Ctr = K$$

Where:

Ctr : is the total running cost,

K : is the constant,

5.3.3. Cost of the kWh output of the solar PV system

The price of the kWh output of the PV system is given by,

$$C_{kwhr} = \frac{Tltc + Ctr}{Kwhro} \quad (15)$$

Where:

$KWhro$: is the output kWhr from the PV systems supplying the load,

C_{kwhr} : is the cost of kWh output of the PV array,

5.4. 5.5 kW PV System Cost

The following tables represent the whole cost related to 5.5 kW PV system in Egyptian pounds.

TABLE (1)
THE COSTS OF THE MAIN COMPONENTS OF PV SYSTEM

Component name	Price in (Egyptian pounds)
1-435 W module	1400
2-battery 200Ah	3500
3-7.5 kW inverter	10,000
4-wiring systems	5000
5-installation system	2000
6-maintenance and labor during 25 years	180,000

TABLE (2)
THE FIXED COST RELATED TO THE 5 YEARS STAGES OF THE WHOLE LIFE TIME OF THE SYSTEM

Number of stages during 5 years stages	Price in (Egyptian pounds)
1-TLTC(1)	163,000
2- TLTC(2)	112,000
3- TLTC(3)	122,000
4- TLTC(4)	117,000
5- TLTC(5)	112,000

From the previous data in the tables, the cost of the kWhr is:

$$C_{kwhr} = 1.705 \text{ Egyptian pounds.}$$

Comparison between Proposed Method and Utility Grid.

The kWh cost for the proposed method is (1.705) Egyptian pounds. While the cost of a kWh for the utility grid is (1.8) Egyptian pounds, according to the Egyptian electric transmission company at the commercial price. On the other hand, solar energy is the better because it is clean and environmentally friendly and does not make noise and not polluted.

VI. CONCLUSION

435 W modules are tested in the site of the Solar Energy Laboratory of Mansoura University, Egypt. This module is an update of all modules in the Egyptian solar energy market, hence; this module is taken to obtain its electrical energy behavior to use with the P-V system. The electrical behavior of the module is estimated at different tilt angles. Three tilt angles are selected: zero, 11, and 31 degrees. The test is carried out to obtain the electrical behavior of the update module. I-V characteristic, maximum power point output characteristic, maximum output current behavior, and voltage at maximum power point characteristic are obtained at different three tilt angles. The best tilt angle is determined. The best test day for the update module is at zero degrees.

Through this research two methods are used to design the PV systems. The proposed method is more accurate than the classic method. The latter method has two drawbacks,

- 1- The number of modules obtained by using this method is greater than that obtained by using the proposed one.

2- There is an excess energy output of the array and it is not stored in the batteries. This excess energy will be lost in the PV system circuit. This is due to that the number of batteries determined by the proposed method has the same values obtained by using the classical method. Hence, the proposed method is an accurate method and it must be used for sizing the PV systems. Through the research, the total lifetime cost of the PV system consists of five stages. Each stage has a time period equals to five years. This period has different costs from each another. On the other hand, the running cost is mainly related to the maintenance and labor costs. These costs are constant for each month. The total lifetime cost of the 5.5 kW system is calculated. So, the kWh cost output of the 5.5 kW system is determined. The cost of the kWh of the previous system is less than the kWh cost output of the Egyptian utility grid.

AUTHORS CONTRIBUTIONS

1. Conceived of the presented idea, **Dr.Saad Eskander and Dr.Mohamed Adel Elsayess**.
2. Development the theory and performing of computations. **Alaa Bunyan**.
3. Performing the analytical methods, verification and building the experimental model,, **Dr.Ahmed Shahin and Alaa Bunyan**
4. Comparison between calculated and simulated characteristics, **Alaa Bunyan and Hanan H. Baihani**
5. Writing the manuscript, **Alaa Bunyan**.

The corresponding author is reasonable for ensuring that the description are accurate and agreed by all authors.

REFERENCES

- [1] Md. Kafiul Islam , Tanvir Ahammad , Enamul Haq Pathan , A N M Mushfiqul Haque and Md. Rezwanul Haque Khandokar:"Analysis of Maximum Possible Utilization of Solar Radiation on a Solar Photovoltaic Cell with a Proposed Model", International Journal of Modeling and Optimization, Vol. 1, No. 1, April 2011.
- [2] Ankita Gaur and G. N. Tiwari:"Performance of Photovoltaic Modules of Different Solar Cells", Hindawi Publishing Corporation, Journal of Solar Energy, Volume 2013, Article ID 734581, 13 pages.
- [3] Zaid Hussein Ali, Abdullah Khalid Ahmed, AmerTayesSaeed:"Modeling Solar Modules Performance Under Temperature and Solar Radiation of Western Iraq", International Journal of Power Electronics and Drive System (IJPED), Vol. 9, No. 4, December 2018, pp. 1842-1850.
- [4] A.Z. Hafeza, A. Solimana, K.A. El-Metwallya, I.M. Ismail: "Tilt and Azimuth Angles in Solar Energy Applications – A Review", Renewable and Sustainable Energy Reviews 77 (2017) 147–168.
- [5] V.V. Tyagi, Nurul A.A. Rahim, N.A. Rahim, Jeyraj A.L. Selvaraj: "Progress in solar PV Technology: Research and Achievement", Renewable and Sustainable Energy Reviews 20(2013) 443-461.
- [6] MehreenGul, YashKotak and Tariq Muneer: "Review on Recent Trend of Solar Photovoltaic Technology", Energy Exploration & Exploitation 2016, Vol. 34(4) 485–526.
- [7] Jugantak K. Roy,SupratikKar,Jerzy Leszczynski: "Development of Solar Cells Theory and Experiment", (Eds), 2021.

- [8] Shah,Arvind: "Solar Cells and Modules", (Ed) 2020.
- [9] Andrew Blakers, NgwaZin, Keith R. McIntosh, Kean Fong: "High Efficiency Silicon Solar Cell", Elsevier-Energy Procedia 33(2013) 1-10.
- [10] Mohamed Talal, Sahar Kaddah, Abdelfattah Eladel,:"Impact of Energy Storage Devices on the Distribution System Stability with Distributed Generation",Mansoura Engineering Journal, Vol. 45(3), pp.1-10.
- [11] Abdelfattah A.Eladel, Azza A.Eldesouky, : "Optimal Economic Dispatch for Multi Heat-Electric Energy Sources Power System", International Journal of Electric Power and Energy Systems, Vol.110, Sep.2019, pp21-35.
- [12] Abdelfattah A.Eladel, Magda I. EL-Afif, Mohammed A. Saeed, Magdi M. El-Saadawi:"Optimal Operation of energy Hubs Integrated with Renewable energy Sources and Storage Devices Considering CO₂ Emissions", Internation Journal of electrical Power and Energy Systems, Vol.117, May 2020, 105719.

APPENDIX [A]

A.1 PV Nameplate 435W

Maximum power(P_{max})	435W
Maximum power voltage(V_{max})	43.55V
Maximum power current(I_{max})	9.99A
Open circuit voltage(V_{oc})	51.61V
Short circuit current(I_{sc})	10.67A
Maximum system voltage	1500VDC
Maximum series fuse rating	20A
Operating temperature	40C - + 85C

A.2 Elevator Motor Nameplate

Maximum power	5.5 kW
voltage	380V 3phase
$P.F(\cos \phi)$	0.75
Speed motor	1500 rpm
Star connection	380 V (current \approx 10A)
Delta connection	220 V (current \approx 20A)

Title Arabic:

تصميم نظام مستقل للطاقة الشمسية الكهروضوئية تم تركيبه في المنصورة - مصر لقيادة مصعد ٥.٥ كيلو وات

Arabic Abstract:

خصص هذا البحث لدراسة الأداء الكهربائي لنظام الطاقة الشمسية الكهروضوئية المستقل ، المستخدم لتغذية مصعد ٥.٥ كيلو واط يتم تمثيل الحمل بواسطة محرك تحريضي متصل بالنظام الكهربائي للمصعد. وقد اختير لوح شمسي بقدرة ٤٣٥ واط المختارة من الأسواق المصرية. تم فحص أداء (I-V) للوحدات الكهروضوئية الشمسية المختارة في البداية. يتم قياس الطاقة الكهربائية المولدة من وحدات الطاقة الشمسية الكهروضوئية (اللوح المختار) بقيم حمولة مختلفة وكذلك عند مستويات مختلفة من الإشعاع الشمسي. وبالتالي ، تسجيل الطاقة الناتجة أثناء النهار في زوايا إمالة مختلفة للوحدات الكهروضوئية الشمسية حيث اختير عدد من زوايا الإمالة المختلفة وهي صفر و ١١ و ٣١ درجة وقد اختير الزاوية صفر كأفضل زاوية في فصل الصيف. يتم استخدام طريقتين مختلفتين للتصميم لاستكشاف التقنية الدقيقة لأنظمة الطاقة الشمسية الكهروضوئية. اما الطريقتين هما الطريقة المقترحة وهي الطريقة التي تتطلب بيانات تجريبية للوح الشمسي في المعمل. أما الطريقة الثانية وهي الطريقة السريعة التي يعتمد في التصميم بالأساس على ساعات التشمس العظمى حيث تختلف ساعات التشمس العظمى من منطقة إلى أخرى.